

Qty. Description

1 UPA 15-90 N



Note! Product picture may differ from actual product

Product No.: [99539189](#)

Grundfos UPA 15-90 N is a domestic booster designed for pressure boosting of drinking water supplied from an external source in residential homes. The UPA booster pumps increase the pressure of domestic water to make the required pressure available at showers, taps and other tapping points.

This pump has an inlet and outlet port of 3/4 inch. The pressure rating of the pump corresponds with PN 10 and a port-to-port length of 160 mm.

The UPA 15-90 N provides the comfort of constant water pressure with automatic start and stop. This is controlled by the integrated flow switch ensuring optimal start/stop of the booster pump according to demand.

The design is robust and built upon corrosion-free materials and stainless-steel pump housing to ensure a long lifetime.

The pump is a canned rotor pump type where pump and motor form an integral unit without shaft seal.

This pump must always be installed with horizontal motor shaft.

This booster has a 2-pole, asynchronous, squirrel-cage motor with built in impedance protection and short circuit proof.

The bearings are lubricated by the pumped liquid.

These constructional features ensure maintenance-free operation.

This pump is also drinking water approved.

- Integrated flow switch: Automatic start and stop according to demand
- Low noise level
- Easy installation: plug and pump compact inline booster
- Integrated non-return valve
- Improved corrosion resistance
- Built in motor protection

Controls:

Flow switch (Yes/No): Y

Liquid:

Pumped liquid: Water
 Liquid temperature range: 2 .. 95 °C
 Selected liquid temperature: 60 °C
 Density: 983.2 kg/m³

Technical:

Rated flow: 0.98 m³/h
 Rated head: 5.462 m
 TF class: 95

Materials:

Pump housing: Stainless steel
 EN 1.4308
 Impeller: Composite
 PP-GF30

Qty.	Description
------	-------------

1	Installation: Range of ambient temperature: 0 .. 40 °C Maximum operating pressure: 10 bar Type of connection: G Size of connection: 3/4 inch Pressure rating for connection: PN 10 Port-to-port length: 160 mm Electrical data: Max. power input: 120 W Mains frequency: 50 Hz Rated voltage: 1 x 230 V Maximum current consumption: 0.48 A Capacitor size - run: 2.5 µF Enclosure class (IEC 34-5): X2D Insulation class (IEC 85): H Built-in motor protection: NONE Power plug: Australian plug Others: Net weight: 2.46 kg Gross weight: 3.58 kg Shipping volume: 0.004 m ³ Country of origin: CN Custom tariff no.: 84137090622081967
---	--



Company name: Land and Water Technology
Created by:
Phone: 08 9209 3330
Email: orders@landwater.com.au
Date: 4/5/2023

99539189 UPA 15-90 N 50 Hz



Pumped liquid = Water
Liquid temperature during operation = 60 °C
Density = 983.2 kg/m³

Description	Value
General information:	
Product name:	UPA 15-90 N
Product No:	99539189
EAN number:	5713830744383
Technical:	
Speed no:	1
Rated flow:	0.98 m ³ /h
Rated head:	5.462 m
Head max:	90 dm
TF class:	95
Materials:	
Pump housing:	Stainless steel
Pump housing:	EN 1.4308
Impeller:	Composite
Impeller:	PP-GF30
Installation:	
Range of ambient temperature:	0 .. 40 °C
Maximum operating pressure:	10 bar
Type of connection:	G
Size of connection:	3/4 inch
Pressure rating for connection:	PN 10
Port-to-port length:	160 mm
Liquid:	
Pumped liquid:	Water
Liquid temperature range:	2 .. 95 °C
Selected liquid temperature:	60 °C
Density:	983.2 kg/m ³
Electrical data:	
Max. power input:	120 W
Mains frequency:	50 Hz
Rated voltage:	1 x 230 V
Maximum current consumption:	0.48 A
Capacitor size - run:	2.5 µF
Enclosure class (IEC 34-5):	X2D
Insulation class (IEC 85):	H
Built-in motor protection:	NONE
Thermal protec:	Impedance protected
Power plug:	Australian plug
Controls:	
Flow switch (Yes/No):	Y
Others:	
Net weight:	2.46 kg
Gross weight:	3.58 kg
Shipping volume:	0.004 m ³
Country of origin:	CN
Custom tariff no.:	84137090622081967

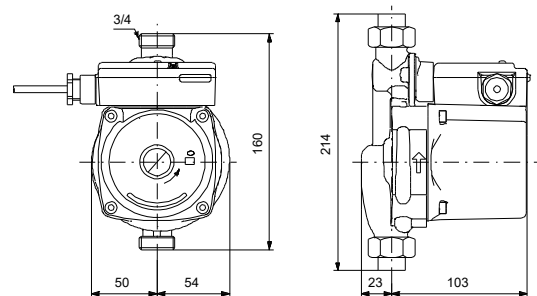
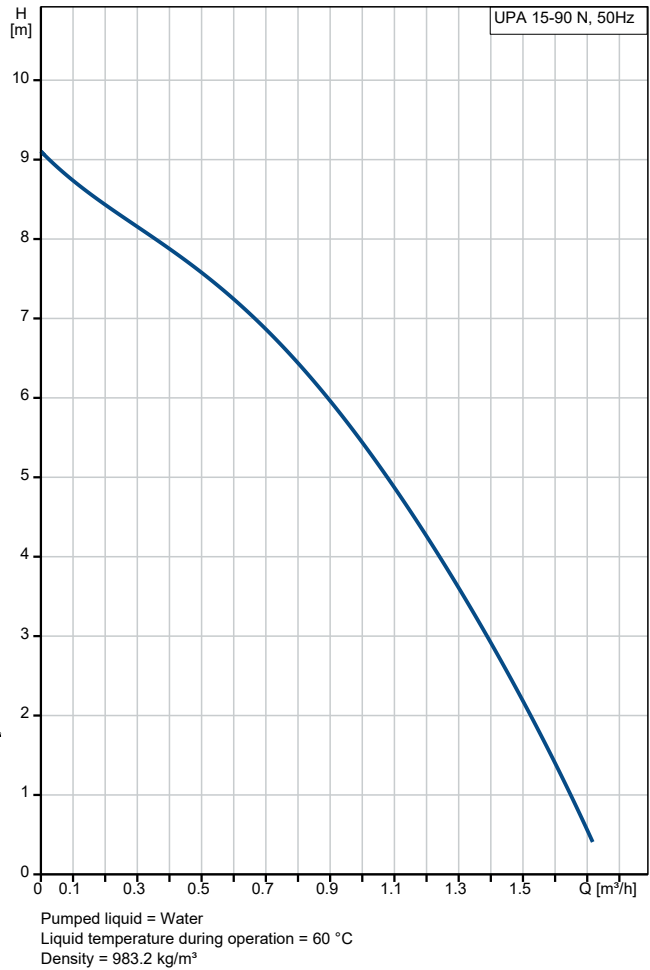

99539189 UPA 15-90 N 50 Hz

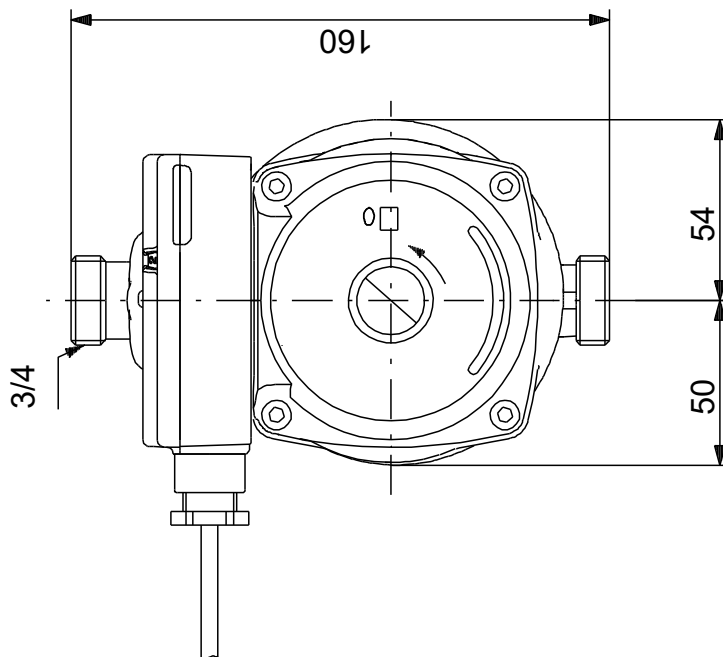
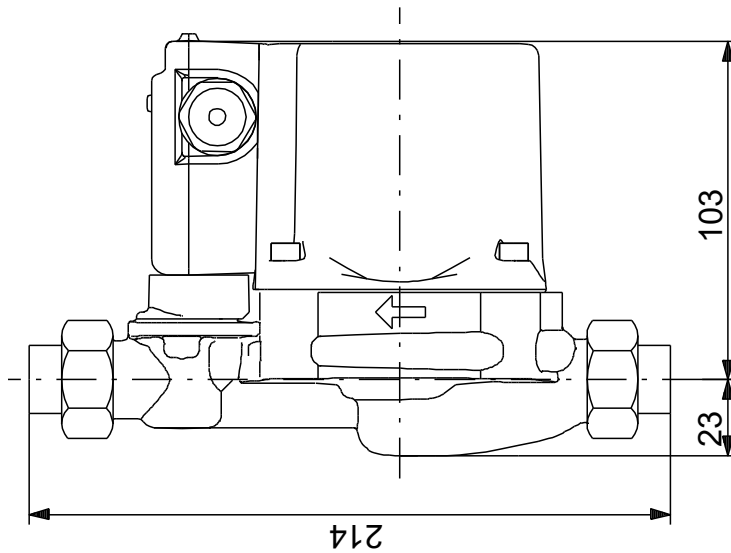

Note! All units are in [mm] unless others are stated.
Disclaimer: This simplified dimensional drawing does not show all details.

