

Qty.	Description
------	-------------

1	COMFORT 15-14 BA PM
---	----------------------------



Note! Product picture may differ from actual product

Product No.: [99164487](#)

The Grundfos Comfort BA PM and BXA PM pumps are designed for recirculation of domestic hot water in single-family and two-family houses securing hot water instantly to all faucets.

The pumps have a corrosion-resistant pump housing suitable for drinking water and are powered by a single-phase, high-efficiency ECM with permanent-magnet rotor.

The AUTOADAPT function incorporates an event log that learns the scheme of demand for hot water in the domestic hot-water system.

Via the event log, the pump predicts when to start circulating hot water ensuring hot water is instantly available at all use points.

Should the consumption pattern change, for example during holidays, the pump will recognise the standstill after 24 hours and automatically adapts to holiday mode.

When returning from holiday, the pump will automatically resume the same consumption pattern as before the holiday.

The unique AUTOADAPT feature is saving up to 48 % heat energy and 97 % motor energy compared with a standard pump in continuous operation.

Additionally, the pump can be set to temperature control mode and continuous operation 100 % for commissioning of the pump or 24 hours instant hot water.

The pumps are equipped with a flushing and disinfection function which automatically circulates water to protect against bacterial growth in the pipes.

COMFORT BXA PM has a built-in isolating valve and a non-return valve (fitting). This ensures that maintenance can be carried out without draining the system. The non-return valve also prevents reversed flow during operation.

99164487 COMFORT 15-14 BA PM

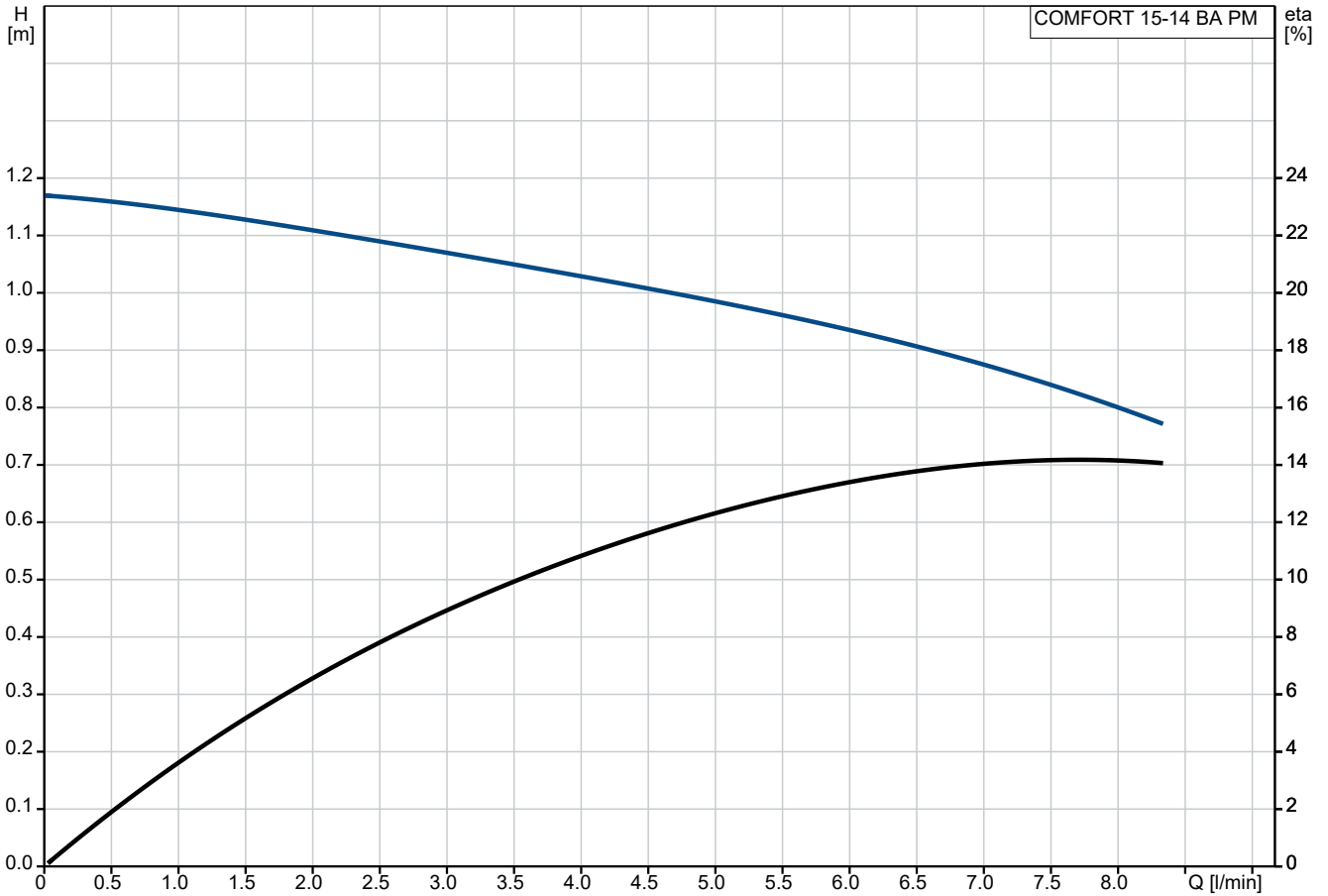

Pumped liquid = Water
 Liquid temperature during operation = 60 °C
 Density = 983.2 kg/m³

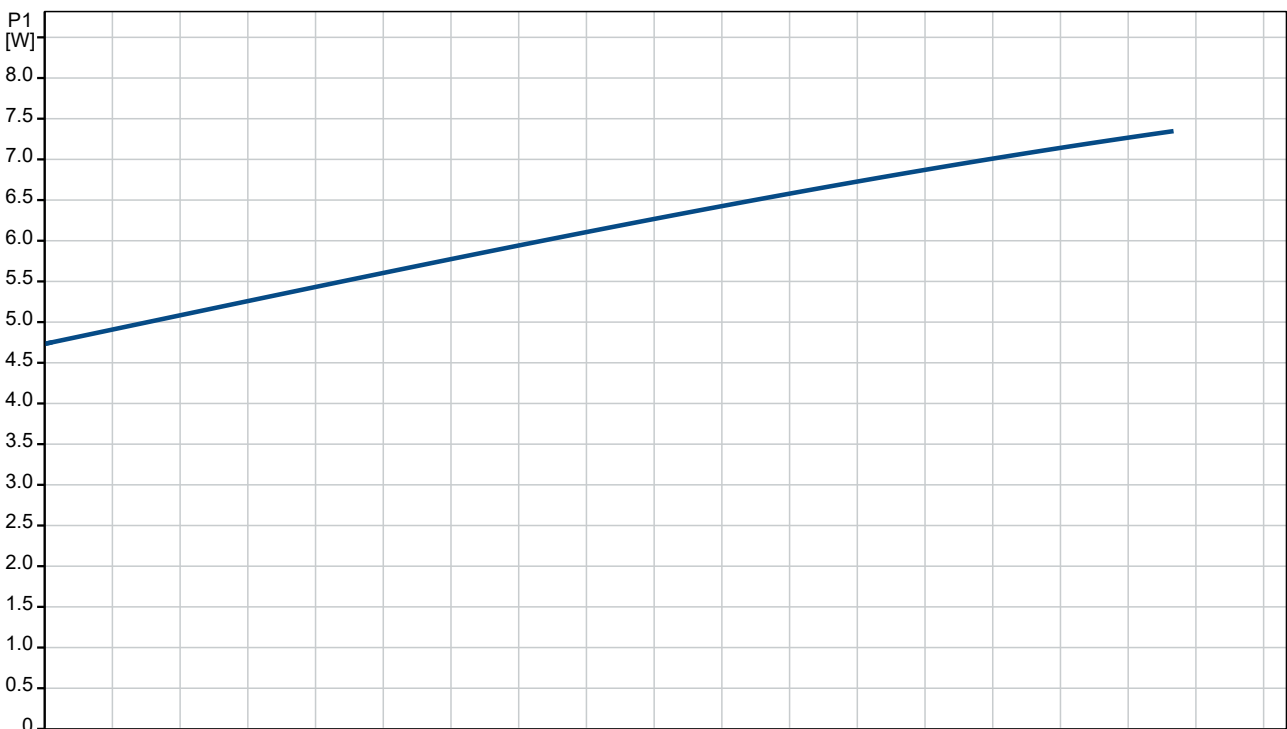

Description	Value
General information:	
Product name:	COMFORT 15-14 BA PM
Product No:	99164487
EAN number:	5712607928490
Technical:	
Speed no:	1
Rated flow:	6.833 l/min
Rated head:	0.9 m
Maximum head:	14 dm
TF class:	95
Approvals:	CE,WEEE,RCM,UKCA
Materials:	
Pump housing:	Brass
Pump housing:	CuZn39Pb3, MS58
Impeller:	Composite
Impeller:	PPO-GF20/Stainless steel
Installation:	
Minimum ambient temperature:	0 °C
Maximum operating pressure:	10 bar
Type of connection:	Rp
Size of connection:	1/2 inch
Pressure rating for connection:	PN 10
Port-to-port length:	80 mm
Liquid:	
Pumped liquid:	Water
Liquid temperature range:	2 .. 95 °C
Selected liquid temperature:	60 °C
Density:	983.2 kg/m ³
Electrical data:	
Max. power input:	7 W
Mains frequency:	50 / 60 Hz
Rated voltage:	1 x 230 V
Current in speed 3:	0.07 A
Capacitor size - run:	0.6 µF
Enclosure class (IEC 34-5):	IP44
Insulation class (IEC 85):	F
Built-in motor protection:	ELECT.
Thermal protec:	Impedance protected
Controls:	
Operation mode include:	Temperature
Others:	
Net weight:	0.9 kg
Gross weight:	1 kg
Shipping volume:	0.003 m ³
Sales region:	Great Britain
Country of origin:	DE
Custom tariff no.:	84137090622081967

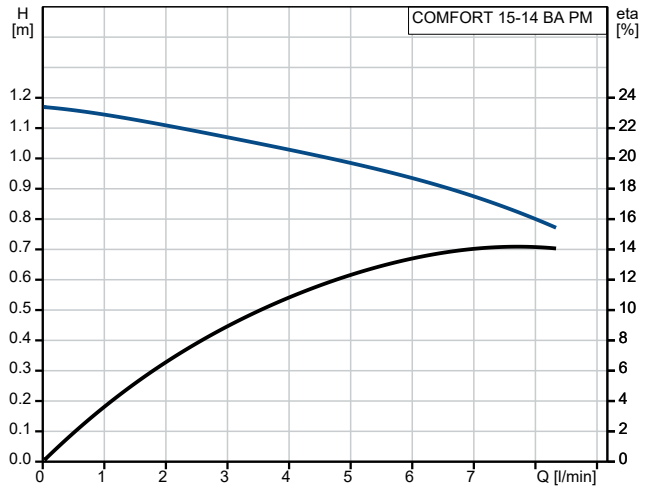

Pumped liquid = Water
 Liquid temperature during operation = 60 °C
 Density = 983.2 kg/m³

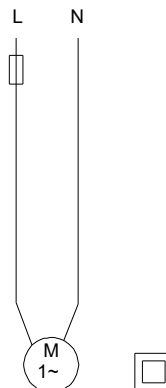
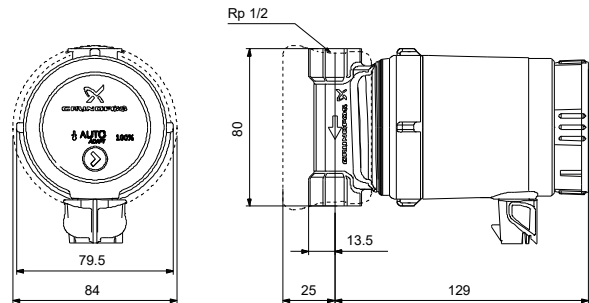
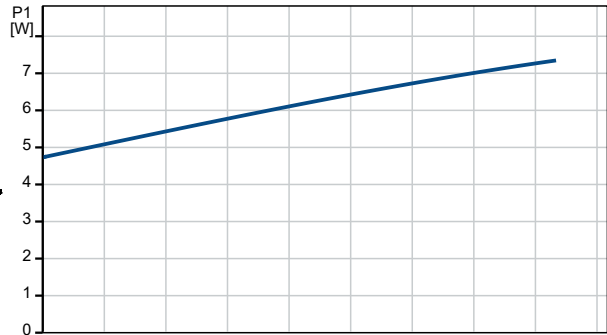

99164487 COMFORT 15-14 BA PM

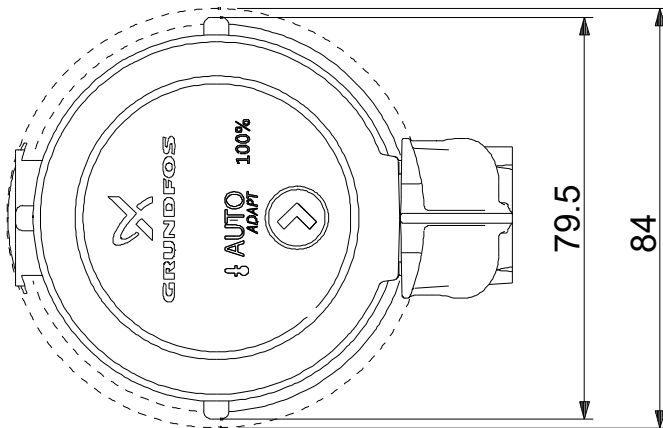
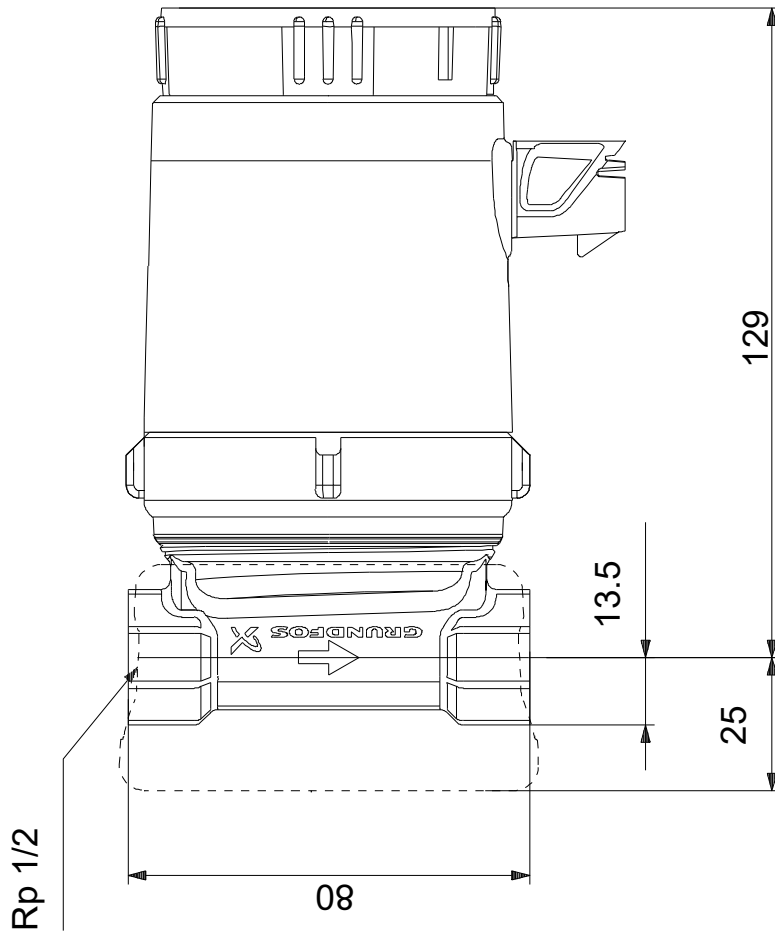

Note! All units are in [mm] unless others are stated.
Disclaimer: This simplified dimensional drawing does not show all details.