

Qty.	Description
------	-------------

1	SOLOLIFT2 D-2
---	---------------



**Note! Product picture may differ from actual product**

Product No.: [97775328](#)

Sololift2 D-2 is a small, compact automatic lifting station suitable for pumping of wastewater off places in private dwellings where greywater (w/o faeces) cannot be led directly to the sewer by means of a natural downward slope.

Sololift2 D-2 is typically used for:

- cabinet showers, washbasins or bidets in basements below sewer level, in connection with the renovation or modernisation of existing buildings, where the location may be remote from the main soil pipe so that a natural slope cannot be established.

Extremely low switching levels for lowest construction heights, advantageously in case of connection of a shower receptor.

Sololift2 D-2 is suitable for confined space conditions in built-in cabinets or also below shower receptors or pedestals.

The pumping of liquids containing other material may cause faults and limit the scope of our guarantee.

The compact lifting station is equipped with

- Cable with or without plug (see technical data)
- Discharge hose connector with several adaptors for pipes with Ø22-36mm

-Integrated non return valve

- Dry and high performance motor unit incl. thermal protection, pressure switch and controller
- Flexible connectors for inlet (adjustable in height) of pipes Ø36 or 40
- Manual anti clogging function and separate drain connection for service
- Venting valve with overflow protection
- Uplift fixation clips

Design according to EN12050-2 and production inspection by external institute with unique features focused on quick installation, long lasting operation and easy clean service.

Liquid:

Liquid temperature range: 0 .. 50 °C

Density: 998.2 kg/m<sup>3</sup>

Technical:

Pump speed on which pump data are based: 2800 rpm

Rated flow: 1.06 l/s

Maximum flow: 1.98 l/s

Rated head: 3.26 m

Type of impeller: VORTEX

Max. Particle: 10 mm

Approvals: CE, CHROHS, MORO, RCM, WATERMARK

Curve tolerance: ISO9906:2012 3B

Materials:

**Qty. Description**

1	Pump housing:	Composite
	Impeller:	Polymer - PA
	Tank:	Plastic PP
	Installation:	
	Range of ambient temperature:	0 .. 40 °C
	Type of inlet connection:	Smooth pipe
	Type of outlet connection:	Smooth pipe
	Size of inlet connection:	36/40/50
	Size of outlet connection:	22/32
	Pressure rating for connection:	PN 1,5
	Number of leads:	3X0,75MM2
	Electrical data:	
	Power input P1:	280 W
	Rated power - P2:	0.16 kW
	Mains frequency:	50 Hz
	Rated voltage:	1 x 220-240 V
	Rated current:	1.3 A
	Cos phi - power factor:	0.95
	Number of poles:	2
	Enclosure class (IEC 34-5):	IP44
	Insulation class (IEC 85):	F
	Power cable type:	H05VV-F-3G
	Length of power cable:	1.2 m
	Power plug:	AUSTRALIEN
	Tank:	
	Tank volume nominal:	2 l
	Others:	
	Net weight:	4.78 kg
	Gross weight:	6.25 kg
	Shipping volume:	0.022 m <sup>3</sup>
	Country of origin:	DE
	Custom tariff no.:	8413709062
	Environmental approvals:	WEEE

## 97775328 SOLOLIFT2 D-2 50 Hz

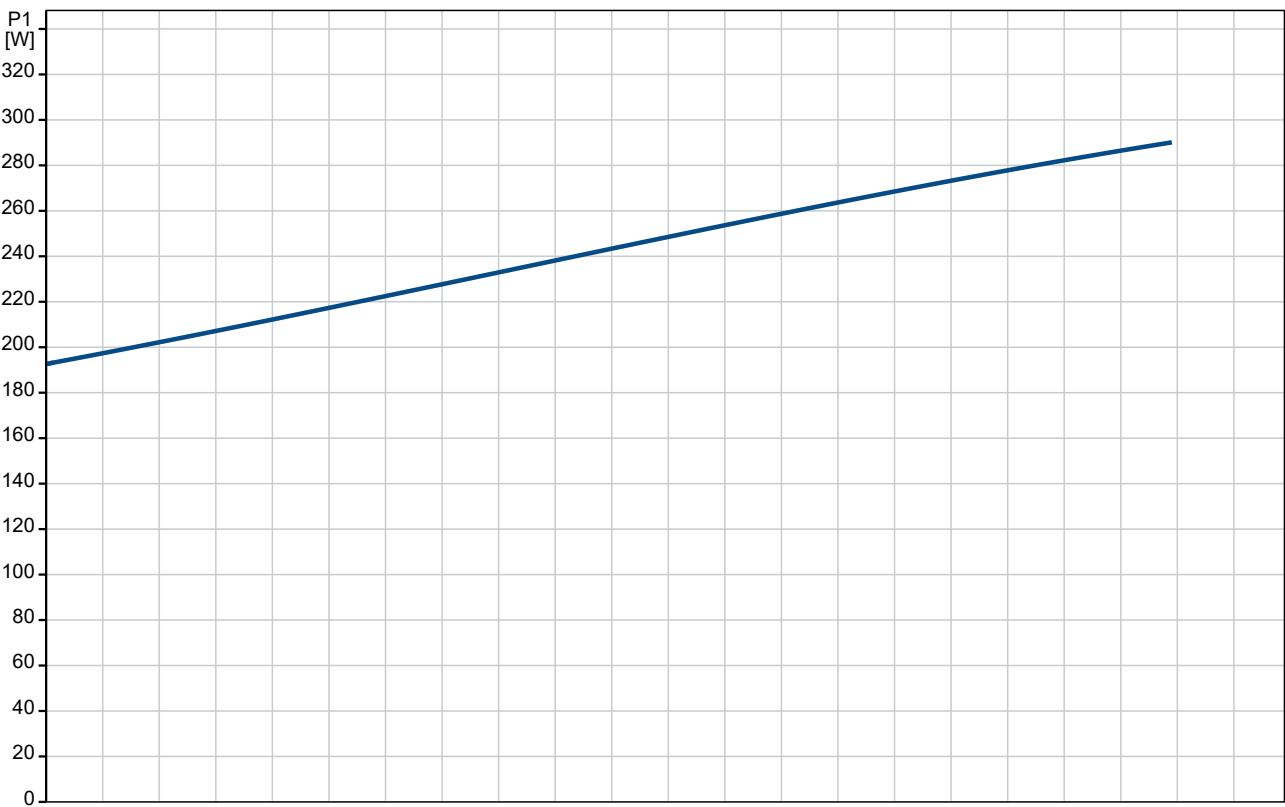
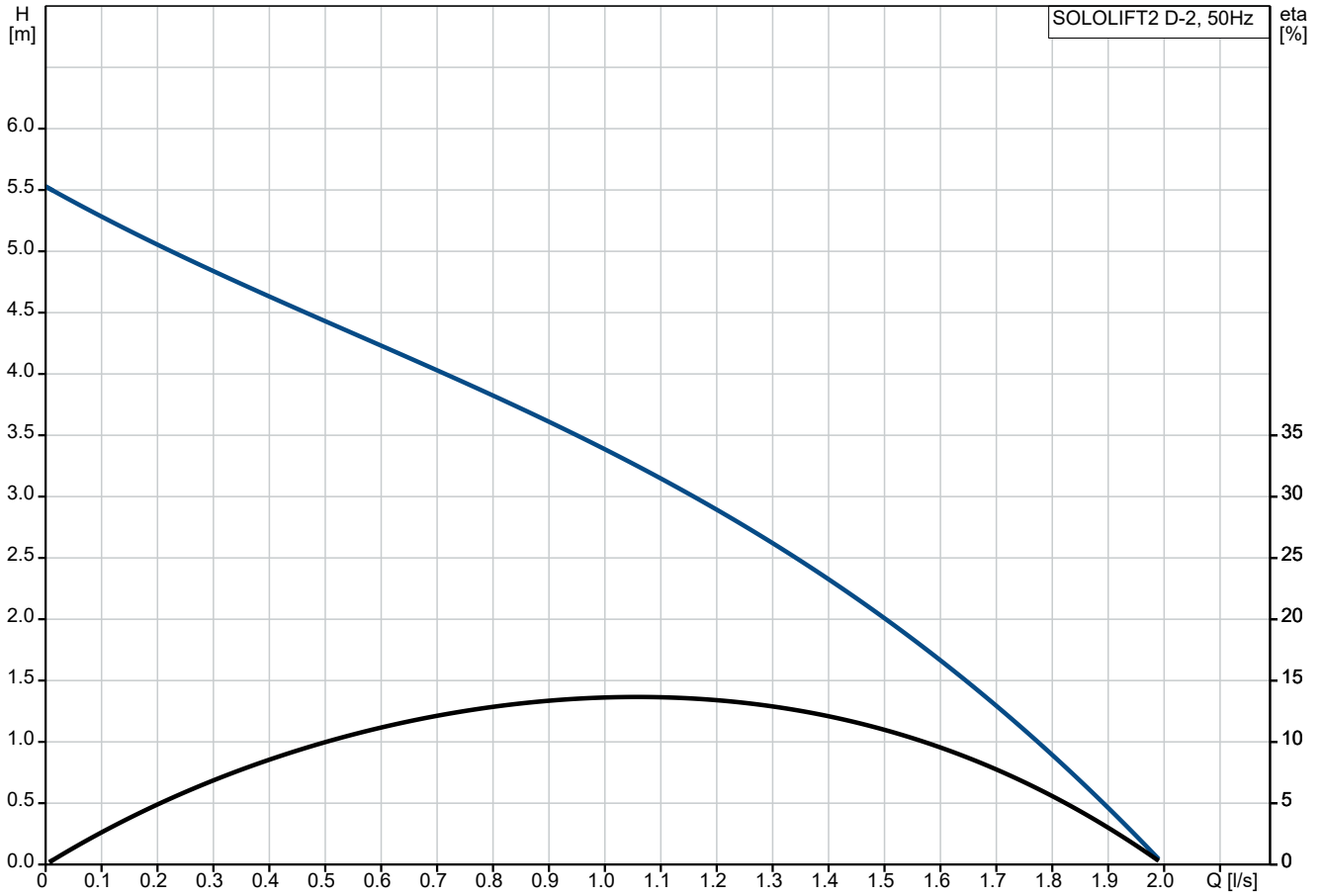

Description	Value
<b>General information:</b>	
Product name:	SOLOLIFT2 D-2
Product No:	97775328
EAN number:	5710624187371
<b>Technical:</b>	
Pump speed on which pump data are based:	2800 rpm
Rated flow:	1.06 l/s
Maximum flow:	1.98 l/s
Rated head:	3.26 m
Maximum head:	5.5 m
Type of impeller:	VORTEX
Max. Particle:	10 mm
Approvals:	CE,CHROHS,MORO,RCM,WAT ERMARK
Curve tolerance:	ISO9906:2012 3B
<b>Materials:</b>	
Pump housing:	Composite
Impeller:	Polymer - PA
Tank:	Plastic
Tank:	PP
<b>Installation:</b>	
Range of ambient temperature:	0 .. 40 °C
Type of inlet connection:	Smooth pipe
Type of outlet connection:	Smooth pipe
Size of inlet connection:	36/40/50
Size of outlet connection:	22/32
Pressure rating for connection:	PN 1,5
Number of leads:	3X0,75MM2
<b>Liquid:</b>	
Liquid temperature range:	0 .. 50 °C
Density:	998.2 kg/m <sup>3</sup>
<b>Electrical data:</b>	
Power input P1:	280 W
Rated power - P2:	0.16 kW
Mains frequency:	50 Hz
Rated voltage:	1 x 220-240 V
Rated current:	1.3 A
Cos phi - power factor:	0.95
Number of poles:	2
Enclosure class (IEC 34-5):	IP44
Insulation class (IEC 85):	F
Thermal protec:	THERMIK S06-160-05
Power cable type:	H05VV-F-3G
Length of power cable:	1.2 m
Power plug:	AUSTRALIEN
<b>Tank:</b>	
Tank volume nominal:	2 l
<b>Others:</b>	
Net weight:	4.78 kg
Gross weight:	6.25 kg
Shipping volume:	0.022 m <sup>3</sup>
Country of origin:	DE
Custom tariff no.:	8413709062
Environmental approvals:	WEEE

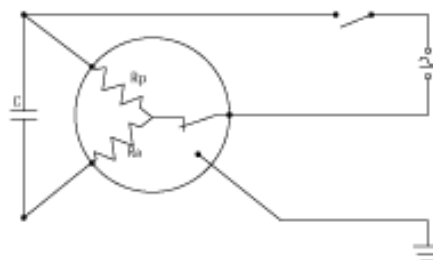
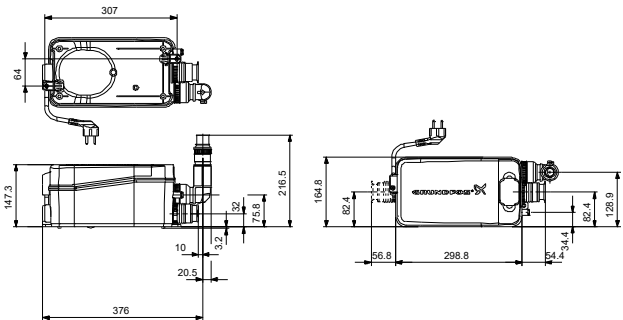
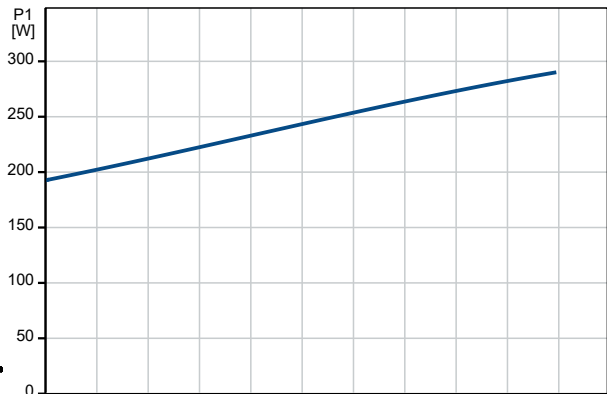
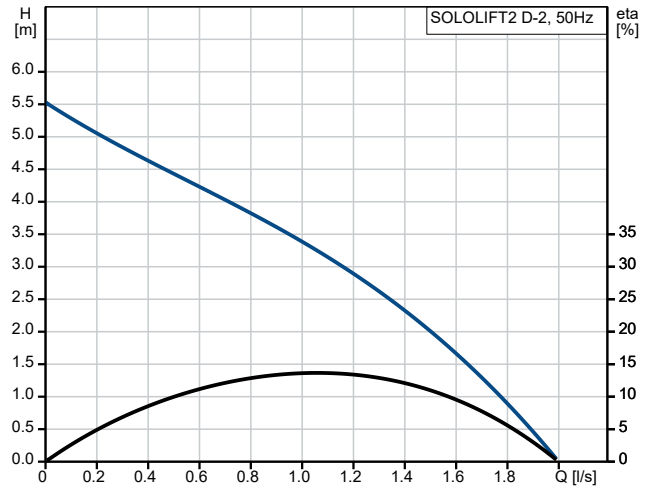

## 97775328 SOLOLIFT2 D-2 50 Hz

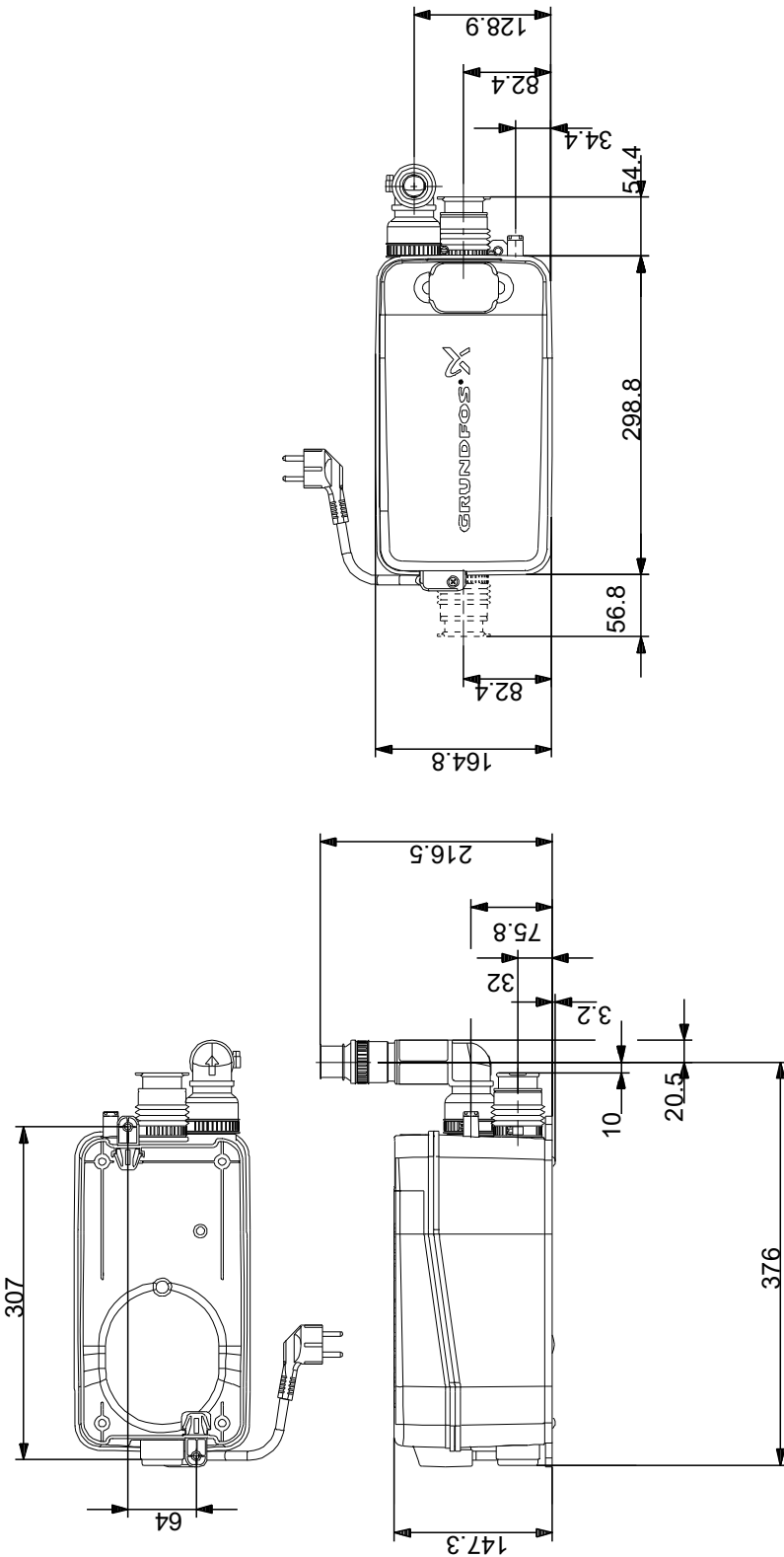

Note! All units are in [mm] unless others are stated.  
 Disclaimer: This simplified dimensional drawing does not show all details.

**97775328 SOLOLIFT2 D-2 50 Hz**

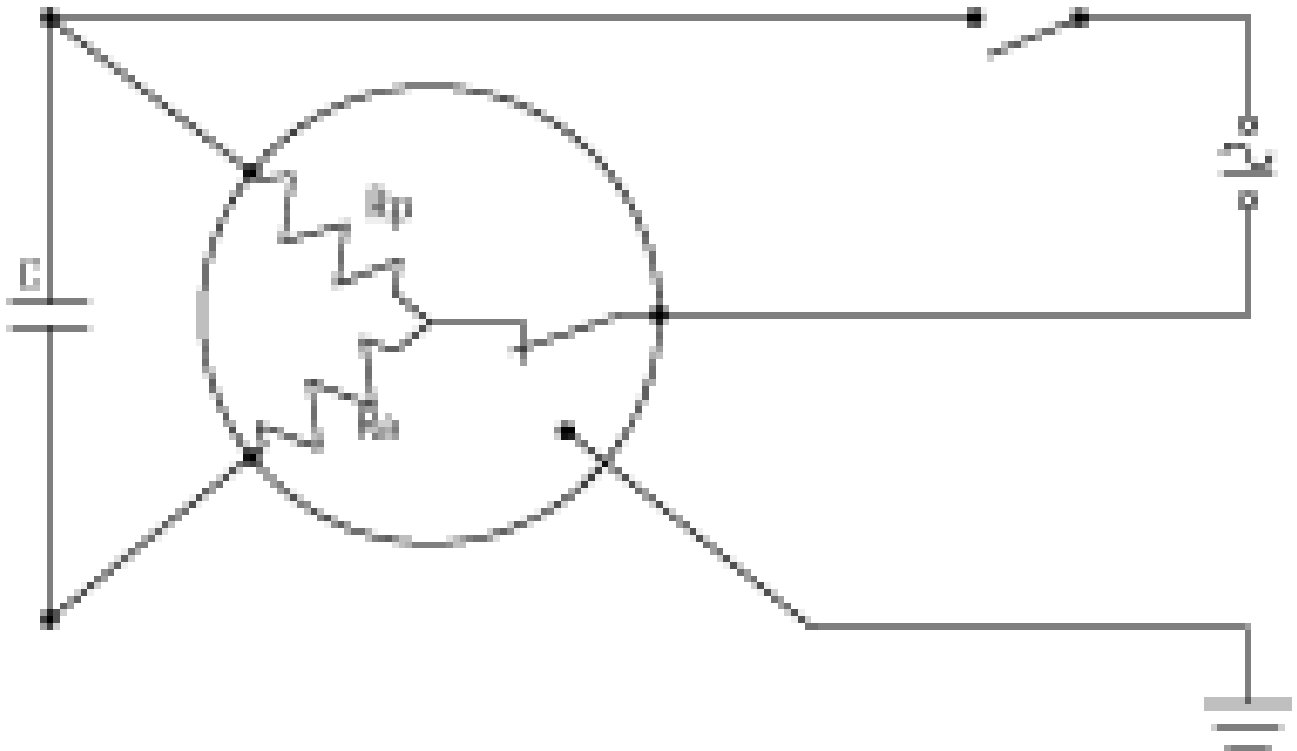

Note! All units are in [mm] unless others are stated.

