

Qty. Description

1 SOLOLIFT2 WC-1



Note! Product picture may differ from actual product

Product No.: [9775324](#)

Sololift2 WC-1 is a small, compact automatic lifting station suitable for pumping of wastewater off places in private dwellings where wastewater cannot be led directly to the sewer by means of a natural downward slope.

Sololift2 WC-1 is suitable for pumping wastewater from a toilet containing toilet paper and faeces with an additional connection on the lid for e.g. a washbasin.

The pumping of liquids containing other material may cause faults and limit the scope of our guarantee.

Sololift2 WC-1 is typically used to dewater:

- toilet and washbasin in basements below sewer level, in connection with the renovation or modernisation of existing buildings, where the location may be remote from the main soil pipe so that a natural slope cannot be established.

The compact lifting station is equipped with

- Cable with or without plug (see technical data)
- Horizontal or vertical fastening possibility of discharge hose connector with several adaptors for pipes with Ø22-40mm

-integrated non return valve

- Dry and high performance motor unit incl. thermal protection, pressure switch and controller
- DN100 toilet connection hose
- Flexible connectors for inlet (adjustable in height) of pipes Ø36 or 40
- Slot for an alarm board with buzzer (accessory)
- Manual anti clogging function and separate drain connection for service
- Venting valve with overflow protection
- Uplift fixation clips

Design according to EN12050-3 and production inspection by external institute with unique features focused on quick installation, long lasting operation and easy clean service.

Note: The discharge adaptor can be mounted vertical or horizontal. Vertical installation increase the flow (s. databooklet and curves)

Liquid:

Liquid temperature range: 0 .. 50 °C

Density: 998.2 kg/m³

Technical:

Pump speed on which pump data are based: 2800 rpm

Rated flow: 1.37 l/s

Maximum flow: 2.48 l/s

Rated head: 6.21 m

Type of impeller: VORTEX with GRINDER

Max. Particle: 25 mm

Approvals: CE,CHROHS,MORO,RCM,WATERMARK

Curve tolerance: ISO9906:2012 3B

Qty. Description

1	<p>Materials:</p> <p>Pump housing: Composite</p> <p>Impeller: Polymer - PPE</p> <p>Tank: Plastic</p> <p style="padding-left: 20px;">PP</p> <p>Installation:</p> <p>Range of ambient temperature: 0 .. 40 °C</p> <p>Type of inlet connection: Smooth pipe</p> <p>Type of outlet connection: Smooth pipe</p> <p>Size of inlet connection: 32/36/40, DN 100</p> <p>Size of outlet connection: 22/25/28/32/36/40</p> <p>Pressure rating for connection: PN 1,5</p> <p>Number of leads: 3X0,75MM2</p> <p>Electrical data:</p> <p>Power input P1: 620 W</p> <p>Rated power - P2: 0.42 kW</p> <p>Mains frequency: 50 Hz</p> <p>Rated voltage: 1 x 220-240 V</p> <p>Rated current: 3 A</p> <p>Cos phi - power factor: 0.92</p> <p>Number of poles: 2</p> <p>Enclosure class (IEC 34-5): IP44</p> <p>Insulation class (IEC 85): F</p> <p>Power cable type: H05VV-F-3G</p> <p>Length of power cable: 1.2 m</p> <p>Power plug: AUSTRALIEN</p> <p>Tank:</p> <p>Tank volume nominal: 9 l</p> <p>Others:</p> <p>Net weight: 7.25 kg</p> <p>Gross weight: 9.55 kg</p> <p>Shipping volume: 0.052 m³</p> <p>Country of origin: DE</p> <p>Custom tariff no.: 8413709062</p> <p>Environmental approvals: WEEE</p>
---	---

97775324 SOLOLIFT2 WC-1 50 Hz

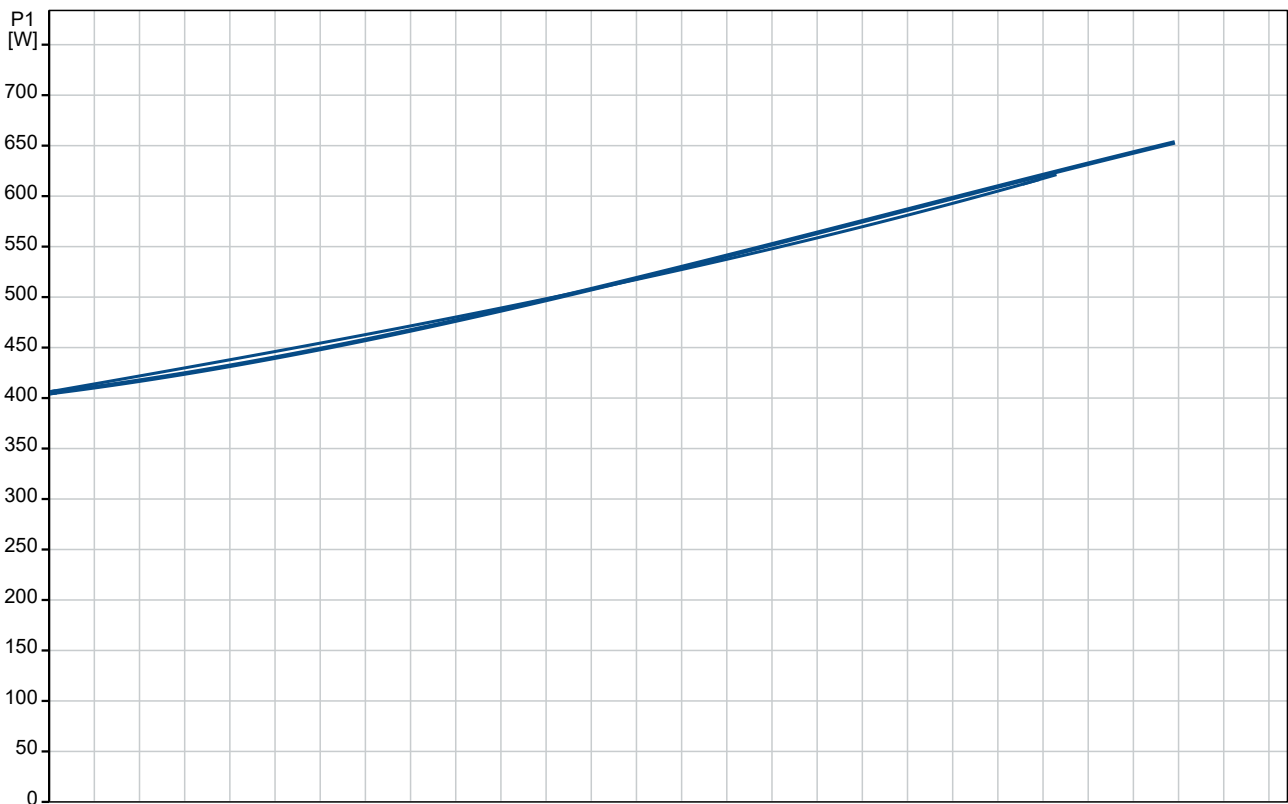
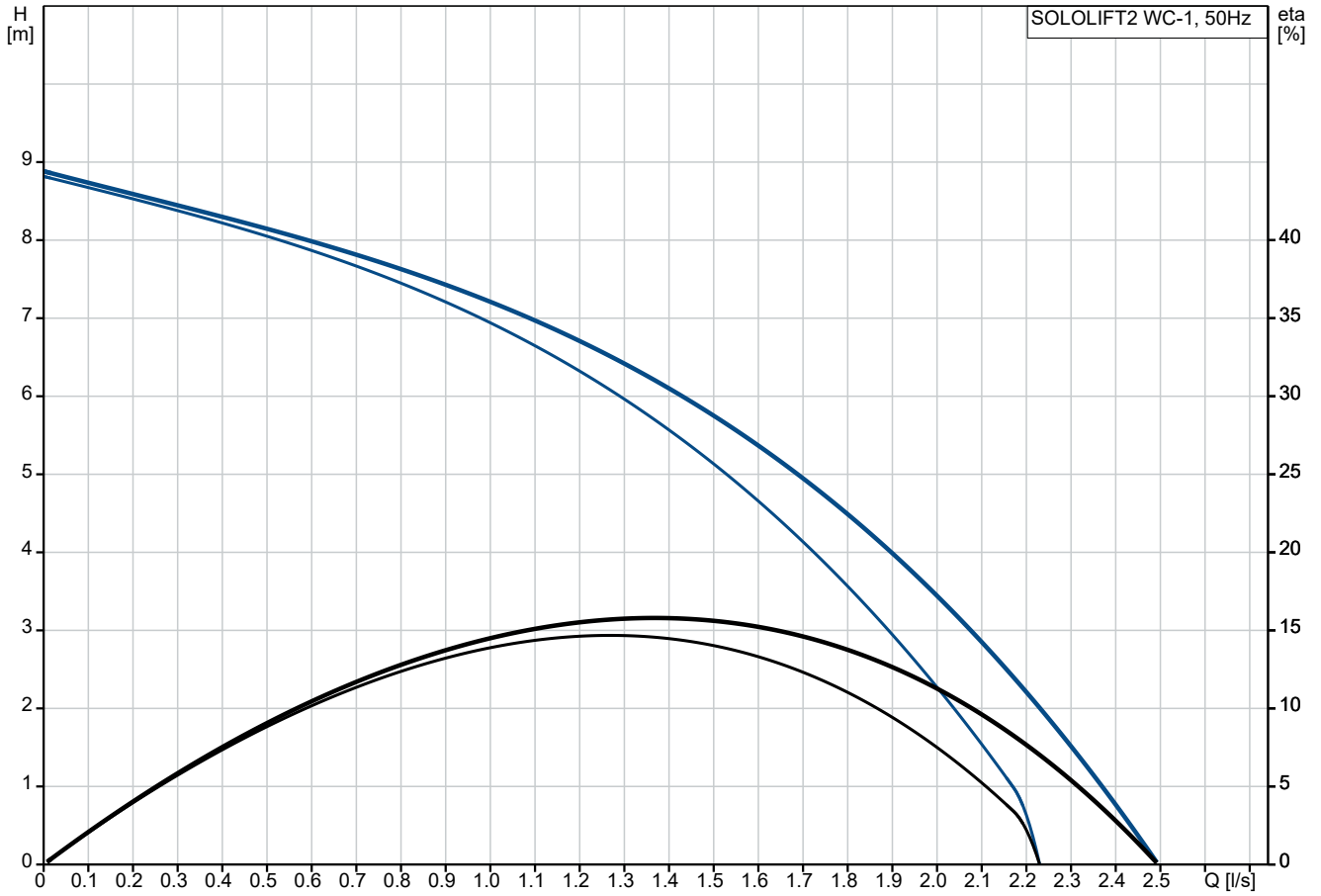

Description	Value
General information:	
Product name:	SOLOLIFT2 WC-1
Product No:	97775324
EAN number:	5710624187333
Technical:	
Pump speed on which pump data are based:	2800 rpm
Rated flow:	1.37 l/s
Maximum flow:	2.48 l/s
Rated head:	6.21 m
Maximum head:	8.5 m
Type of impeller:	VORTEX with GRINDER
Max. Particle:	25 mm
Approvals:	CE, CHROHS, MORO, RCM, WAT ERMARK
Curve tolerance:	ISO9906:2012 3B
Materials:	
Pump housing:	Composite
Impeller:	Polymer - PPE
Tank:	Plastic
Tank:	PP
Installation:	
Range of ambient temperature:	0 .. 40 °C
Type of inlet connection:	Smooth pipe
Type of outlet connection:	Smooth pipe
Size of inlet connection:	32/36/40, DN 100
Size of outlet connection:	22/25/28/32/36/40
Pressure rating for connection:	PN 1,5
Number of leads:	3X0,75MM2
Liquid:	
Liquid temperature range:	0 .. 50 °C
Density:	998.2 kg/m ³
Electrical data:	
Power input P1:	620 W
Rated power - P2:	0.42 kW
Mains frequency:	50 Hz
Rated voltage:	1 x 220-240 V
Rated current:	3 A
Cos phi - power factor:	0.92
Number of poles:	2
Enclosure class (IEC 34-5):	IP44
Insulation class (IEC 85):	F
Thermal protec:	THERMIK S06-150-05
Power cable type:	H05VV-F-3G
Length of power cable:	1.2 m
Power plug:	AUSTRALIEN
Tank:	
Tank volume nominal:	9 l
Others:	
Net weight:	7.25 kg
Gross weight:	9.55 kg
Shipping volume:	0.052 m ³
Country of origin:	DE
Custom tariff no.:	8413709062
Environmental approvals:	WEEE

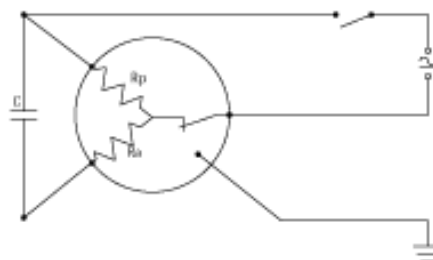
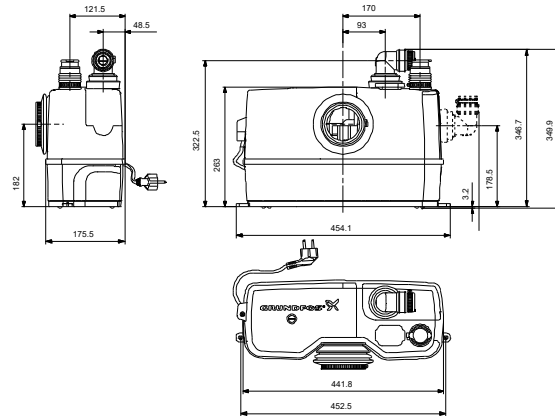
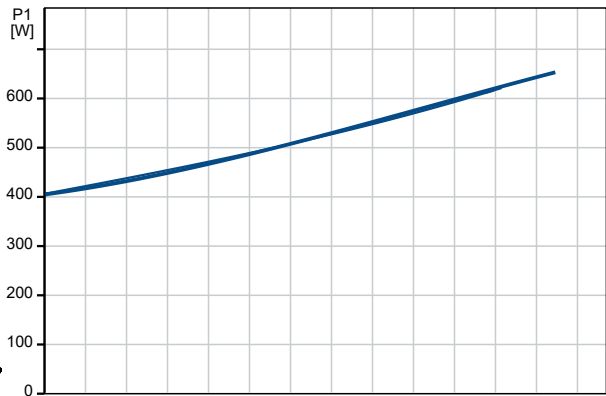
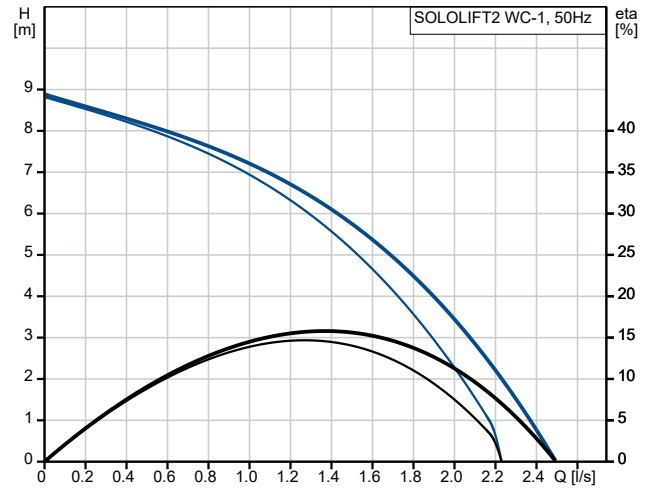

97775324 SOLOLIFT2 WC-1 50 Hz

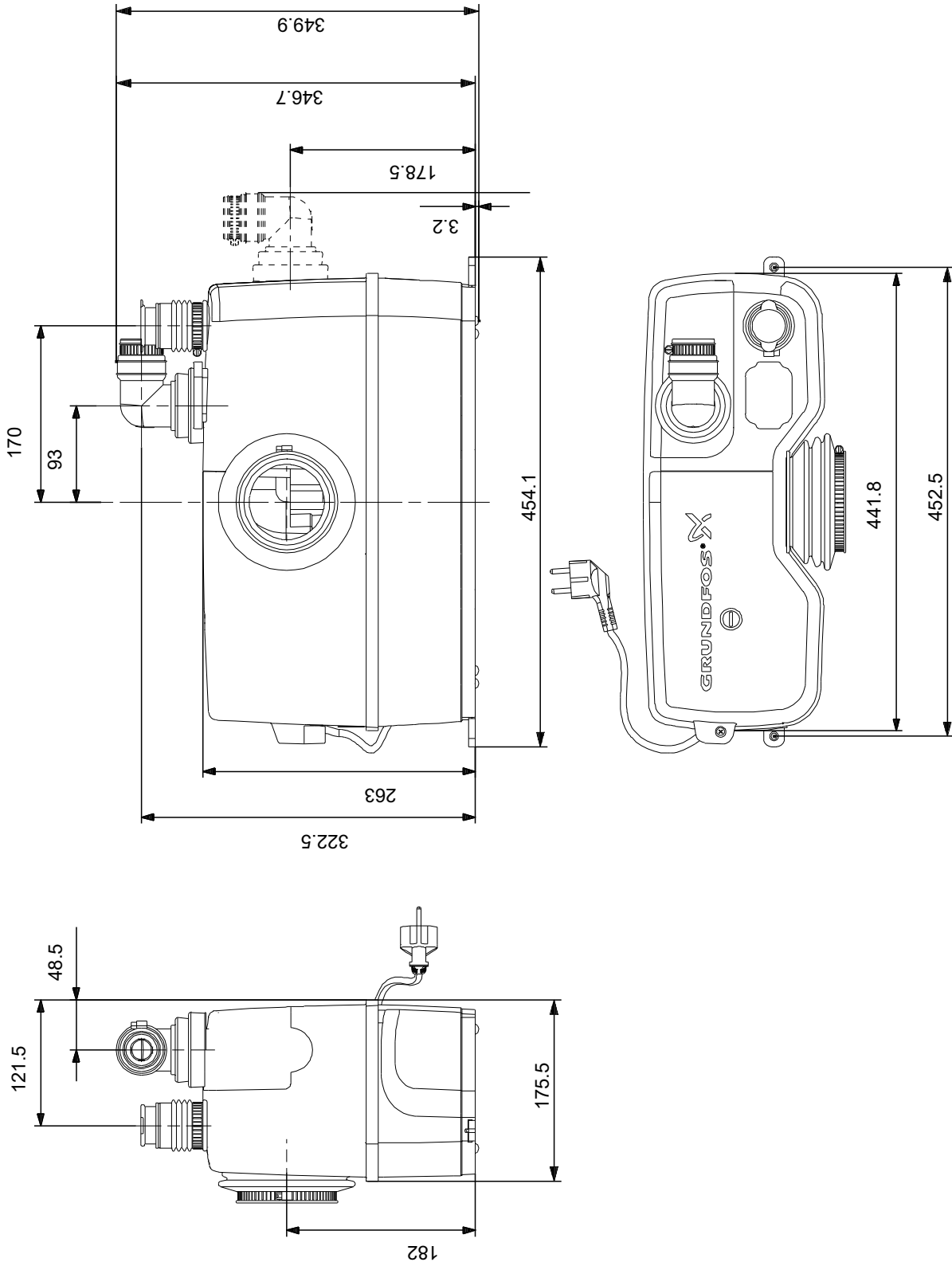

Note! All units are in [mm] unless others are stated.
 Disclaimer: This simplified dimensional drawing does not show all details.

97775324 SOLOLIFT2 WC-1 50 Hz

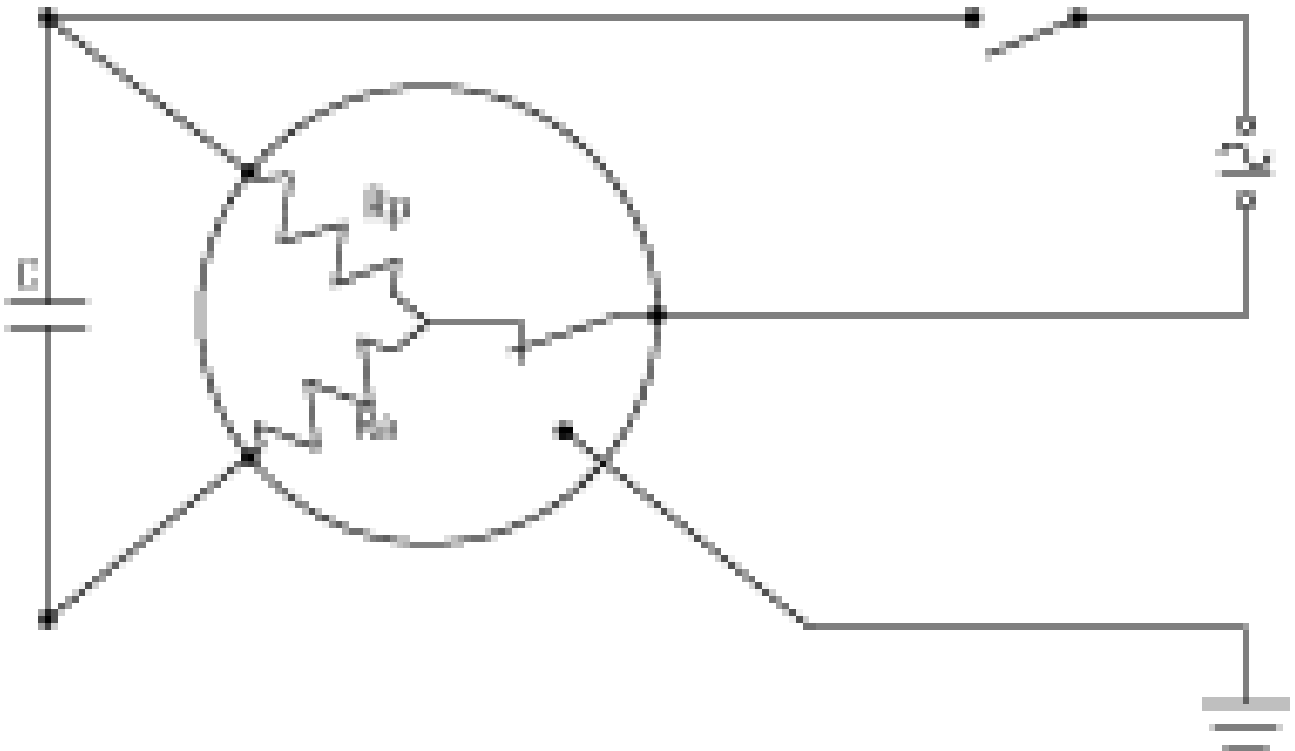

Note! All units are in [mm] unless others are stated.

