



BIA-iPROTECT

Single-Phase Pump Control and Protection module PN 802697

Installation and Operation Manual



1. Introduction

Thank you for choosing a Bianco iCon iPROTECT Intelligent Pump Controller.

An iPROTECT provides significant protection for direct start (DOL), single phase pumps from 0.37kW – 2.2kW with PSC MOTORS (Permanent-Split Capacitor) with start and run windings). It also offers a number of control and operation modes to suit a variety of applications.

The controller is easy to set up with a push button calibration for over and under-load. The iPROTECT also allows for dry-run protection without float switches or probes.

The LCD screen displays the pump running state and provides the user a wealth of useful information.

The iPROTECT is particularly useful where there is the need to control and protect single pump installations managing the automatic operation by a variety of switching methods.



2. Contents

1. Introduction	2
2. Contents	2
3. Technical Specifications	3
4. Warnings and Cautions	3
5. Display	4
6. Operation and Programming - navigation	5
7. Program Parameters	6
8. Programming for Cutter/Grinder/Macerating pumps	8
9. Drainage Mode - Electrical Connections; floats or probes	9
10. Drainage Mode – Control via Pump Float	10
11. Drainage Mode – LCD running state images	10
12. Transfer Mode - Electrical Connections; floats or probes	11
13. Transfer Mode - LCD running state images	12
14. Boosting Mode - Electrical Connections; floats or probes	13
15. Boosting Mode - LCD running state images	14
16. Bore Pumps - Connecting 2 wire and 3 wire bore pumps	15
17. Communication link – RS485	16
18. Fault messages – possible causes and solutions	18
19. Warranties – Terms and Conditions	19

3. Technical Specifications

Controller Modes	Automatic or Manual pump operation. Liquid level control via float switch, level transducer or pulse electrode probes. Pressure control via pressure switch or transducer.
Protection functions:	Dry run (underload), Overload, Pump Stalled, Transient surge, Under voltage, Over voltage, Repeated start, Over temperature, Short circuit
Input Voltage	230V +5% -10%
Rated output power	0.37 – 2.2kW P2 power (rated up to 25A input)
Working temp	-25 to +55 deg C 20% to 90% relative humidity, non-condensing
Enclosure	250mm tall, 197mm wide, 115 deep. 1.6kg. IP54
Trip response times (set)	Open phase – Less than 2 sec Short circuit – less than 0.1 sec
Trip Voltage (User adjustable)	Over voltage – 115% of rated input voltage default Under voltage – 80% of rated input voltage default
Trip response times (User adjustable)	Dry run (Under-load) 6 sec Overload 5 sec Under Voltage Less than 5 sec Over voltage Less than 5 sec
Recovery times	Dry run (Under-load) 30 min default Overload 30 min default Under Voltage 5 min – non adjustable Over voltage 5 min – non adjustable
RS485 Technical interface	RS485 Bus Interface: asynchronous semi duplex 1200,2400,4800,9600 bps (default 9600bps) MODBUS protocol (RTU)
Alarms	Internal audible alarm only. External alarm connection unsupported





4. Warnings and Cautions

	Please read the manual fully and carefully before starting. Retain the manual for future reference.
	This appliance is not intended for use by persons (including children) with reduced physical, sensory or mental capabilities, or lack of experience and knowledge, unless they have been given supervision or instruction concerning use of the appliance by a person responsible for their safety. Children should be supervised to ensure that they do not play with the appliance.

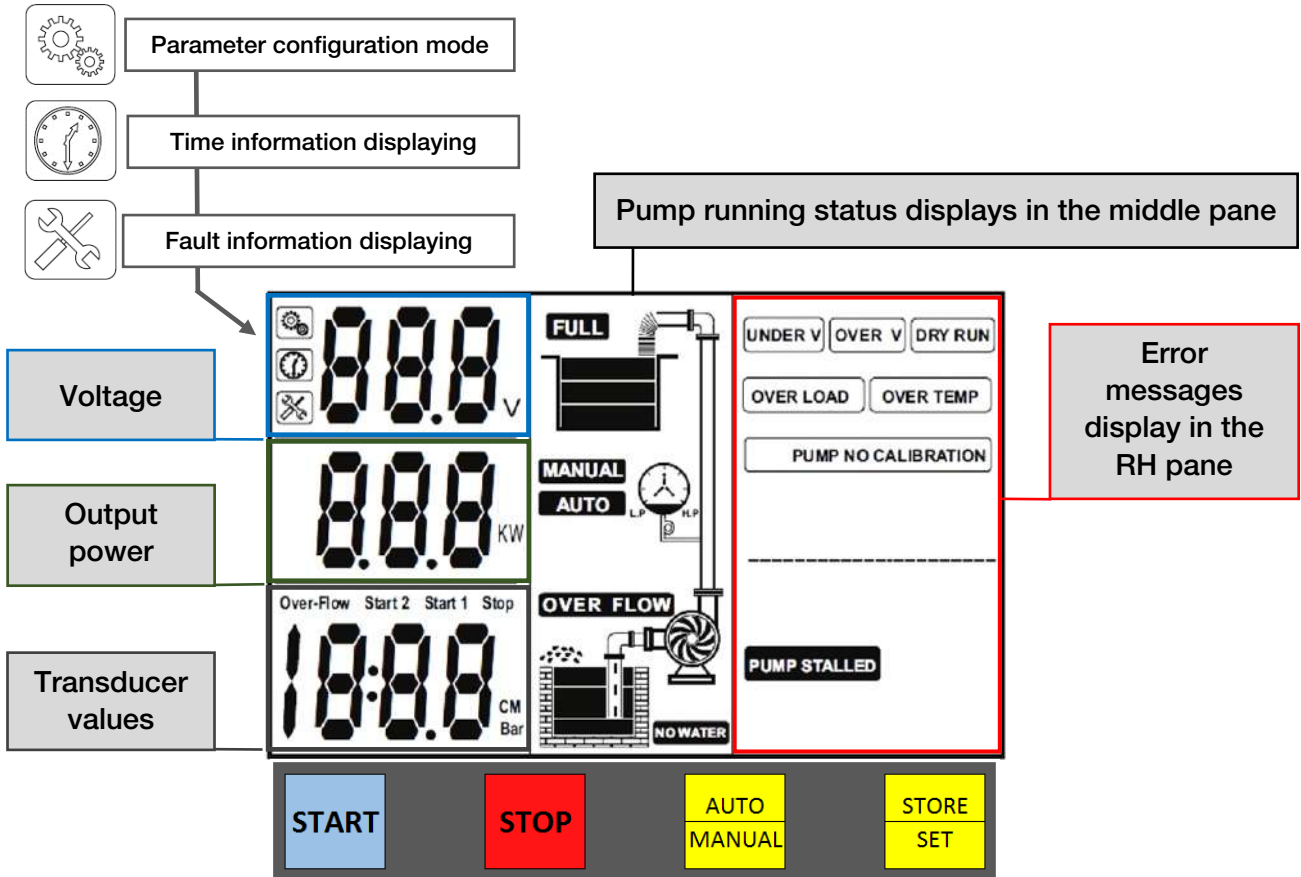
5. Display

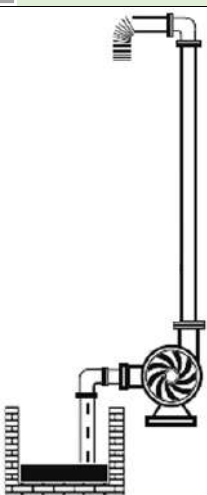
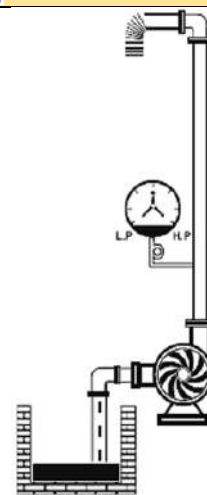
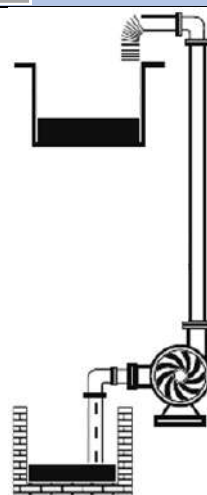
The iProtect display provides a real time indication of the operational mode and the current state of the controller, including real-time voltage/load and any error messages.

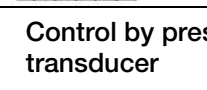

Drainage	Boosting	Transfer
<div style="display: flex; align-items: center;"> <div style="margin-right: 10px;"> <input type="checkbox"/> ON 1 2 3 </div> <div>Control by floats or probes</div> </div> 	<div style="display: flex; align-items: center;"> <div style="margin-right: 10px;"> <input type="checkbox"/> ON 1 2 3 </div> <div>Control by pressure switch</div> </div> 	<div style="display: flex; align-items: center;"> <div style="margin-right: 10px;"> <input type="checkbox"/> ON 1 2 3 </div> <div>Control by floats or probes</div> </div> 
<div style="display: flex; align-items: center;"> <div style="margin-right: 10px;"> <input type="checkbox"/> ON 1 2 3 </div> <div>Control by level transducer</div> </div> 	<div style="display: flex; align-items: center;"> <div style="margin-right: 10px;"> <input type="checkbox"/> ON 1 2 3 </div> <div>Control by pressure transducer</div> </div> 	<div style="display: flex; align-items: center;"> <div style="margin-right: 10px;"> <input type="checkbox"/> ON 1 2 3 </div> <div>Control by level transducer</div> </div> 

Function switch located upper right-hand side of main board. Cycle power after changing.

6. Operation and Programming - navigation

Switching to manual mode



 Press together then release

In MANUAL MODE, the pump will not operate unless the START button is pressed.

Returning to Auto mode

 Press to return to Auto mode

After 30 sec without button-press activity the controller will exit the parameter menu

 STARTS the pump

 STOPS the pump

Erasing a calibration.

 Press STOP for 5 sec

The display will flash **PUMP NO CALIBRATION**



Following new pump fitment or any system alterations a fresh pump calibration should be performed. Auto Pump Calibration requires water in the system to achieve real-world operating conditions. If pumps are calibrated without water, overload and pump stalled errors may occur later.

Auto pump calibration.

Allow the pump to run and settle into it's 'normal' operating state before saving the calibration



 START the pump

 Press STORE/SET

 Exit to Auto mode

Accessing the Parameter menu

 Press STORE/SET for 5 sec

 STORE/SET to scroll

 STOP to alter value

 Press and hold STORE/SET to save all changes

Accessing the Last 5 error messages

 Hold STOP Press AUTO/MANUAL

Use the Auto/Manual button to scroll

 Press STOP to exit

View the accumulated running time

 Hold STORE/SET Press STOP

 Press STOP to exit

In situations where it isn't possible to run the pump to achieve a real-world calibration, enter the P1 kW rating manually at Parameter 008

See Pg 17 for additional notes regarding calibration

7. Program Parameters

Note that earlier versions of firmware will have fewer parameters. Ensure the screen is displaying the image that corresponds with your desired change.

<p>001</p> <p>001</p>	<p>The controller ID</p> <p>Range 0 - 254 Default = 1</p>
<p>002</p> <p>004</p>	<p>RS 485 Speed</p> <p>01 = 1200 bps 02 = 2400 bps 03 = 4800 bps 04 = 9600 bps</p> <p>Range 0 - 4 Default 4 = 9600 bps</p>
<p>003</p> <p>00</p>	<p>Odd-Even parity</p> <p>00 = no parity 01 = odd parity 02 = even parity</p> <p>Default setting 00 = no parity</p>
<p>004</p> <p>006^s</p>	<p>Dry run protection trip response time in seconds (S)</p> <p>Range 0 seconds – 60 seconds Default value 6 seconds</p>
<p>005</p> <p>030^m</p>	<p>Recovery time for dry run protection in minutes (M)</p> <p>Range 0 - 254 minutes Default value is 30 minutes</p>
<p>006</p> <p>005^m</p>	<p>Overload trip response time in minutes (M)</p> <p>Range 0 - 60 minutes Default value is 5 minutes</p>
<p>007</p> <p>002^m</p>	<p>Under / Over voltage trip response time in minutes (M)</p> <p>Range 0 – 60 minutes Default value is 2 minutes</p>

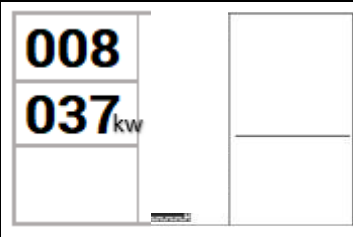
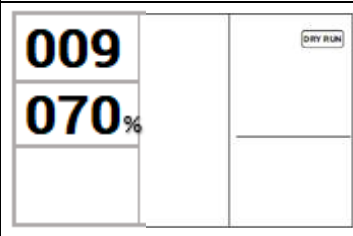
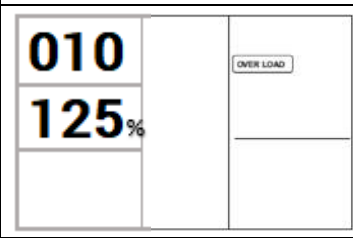
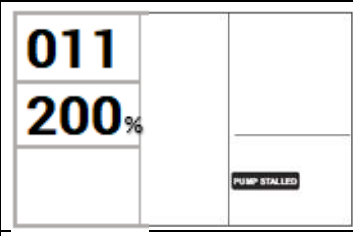
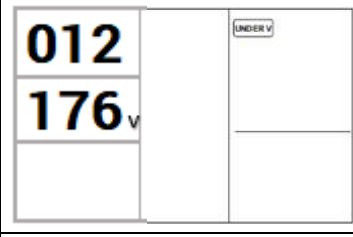
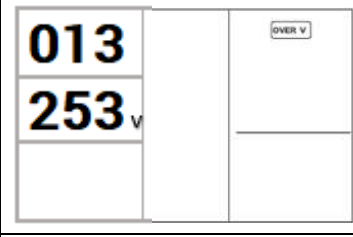
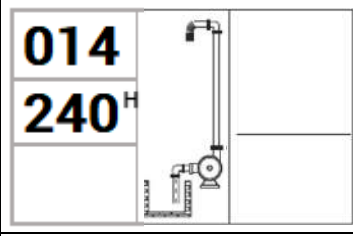
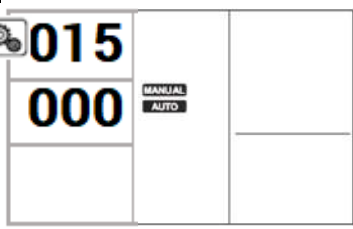
	<p>Rated power output to the pump (P1 power)</p> <p>Range 0 – 2.99kW Default setting is 3.00kW</p> <p>Button Press calibration saves the running value to this location</p>
	<p>The trip response ratio of the dry-running (underload) protection as a percentage of the rated current</p> <p>Range 0 – 95% Default setting is 70%</p> <p>Control by means of a float attached directly to the pump: set to 0%</p>
	<p>The trip response ratio of the Overload Protection as a percentage of the rated current.</p> <p>Range 0 – 135% Default setting is 135%</p>
	<p>The trip response ratio of the Pump-Stalled Protection as a percentage of the rated current.</p> <p>Range 0 – 240% Default setting is 200%</p> <p><i>A pump-stalled event is a 'critical error' and has no auto-restart time</i></p>
	<p>The trip voltage of the Under Voltage Protection (V)</p> <p>Range 0 – 192V Default setting is 176V</p>
	<p>The trip voltage of the Over Voltage Protection (V)</p> <p>Range 0 – 276V Default setting is 253V</p>
	<p>Note: Only Applicable to Drainage Mode</p> <p>Anti-seize parameter.</p> <p>In auto mode, if pump has not run for XX hours, controller will run the pump for 3 seconds.</p> <p>Range 0 – 254 hours Default setting is 240 hours.</p>
	<p>LCD Button operation lock function</p> <p>00 = LCD and button function inactive 01 = LCD and button function activated Default setting is 00 = inactive</p> <p>If this function is activated, to unlock the controller hold MODE button then press and hold the STORE/SET button. The controller will count down 6 – 10 seconds. Release all buttons and the controller will switch to manual mode with all buttons unlocked</p>

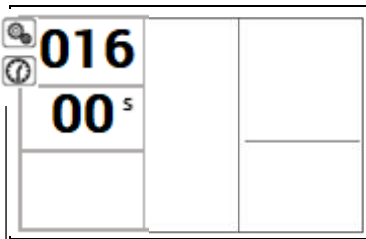
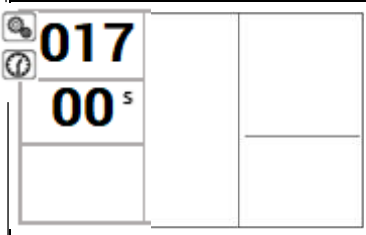
	<p>Delay time for starting the pump in seconds</p> <p>In auto mode, when the controller has met the conditions to start the pump, there will be a delay equal to setting 016 parameter</p> <p style="text-align: center;">Default setting is 0 seconds</p>
	<p>Delay time for stopping the pump in seconds</p> <p>In auto mode, when the controller has met the conditions to stop the pump, there will be a delay equal to setting 017 parameter</p> <p style="text-align: center;">Default setting is 0 seconds</p>

If a replacement pump is installed, the previous calibration should be removed and a new calibration performed.



Consult White International prior to changes to parameters 001 to 017.

Changes without consulting White International may void your pump warranty.

8. Programming for Cutter/Grinder/Macerating pumps

Pumps fitted with a cutting, grinding or macerating mechanism are at risk of jamming or attempting to start in a 'locked rotor' state.

The iProtect, due to its rapid response, provides superior pump protection compared to traditional overload setups.

For pumps with a cutting, grinding or macerating mechanism, the installer may elect to manually enter the pump nameplate kW at Parameter 008 to ensure the pump can achieve its maximum torque.

Note: if the running power is less than 75% of the rated full load power check the pump sizing or system.

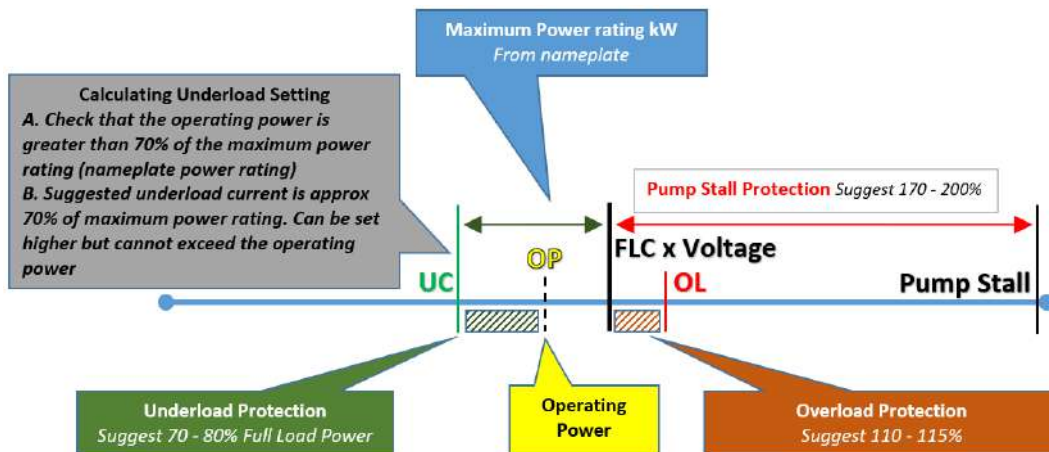

For pumps controlled by their own float, see Section 9. **Program parameter 009 to 0%**

9. Drainage Mode - Electrical Connections; floats or probes

The controller is rated IP54. It should be installed vertically where it has excellent ventilation away from direct sunlight or exposure to adverse weather. Installation inside a separate open fronted enclosure is suggested.

Any electrical alterations or additional connections should be carried out by a suitably qualified technician. Ensure suitably rated circuit breakers are installed.



Isolate the controller before opening the cover to access the low voltage circuit connections.

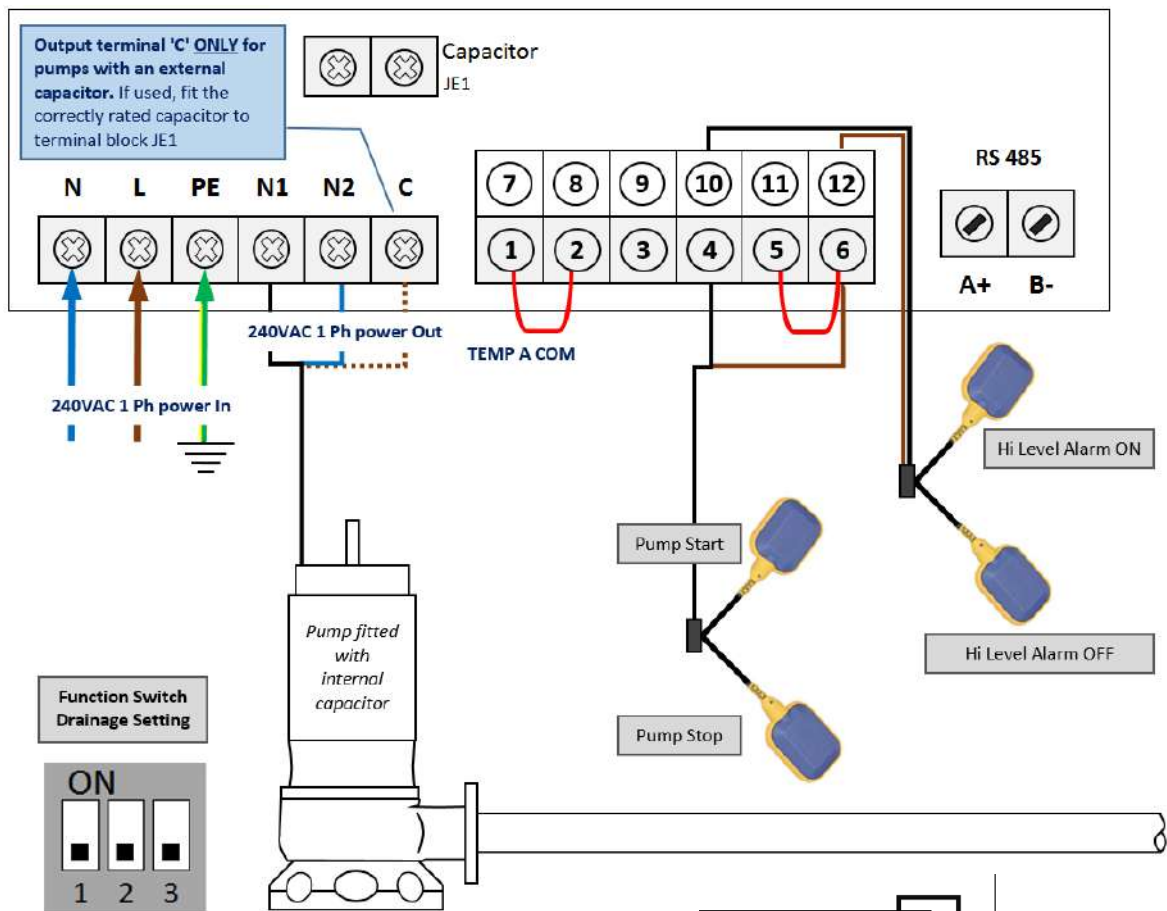

When operating a pump with its own float fitted, ensure it is lower than the control float OR tie the float in the upward (permanently on) position

Terminals 1 and 2 are for connection to motor thermal protection. If not available leave the jumper wire in.

Terminals A+ and B- are for MODBUS communication (RS485).

Probes are not recommended for use with black water or contaminated liquids.

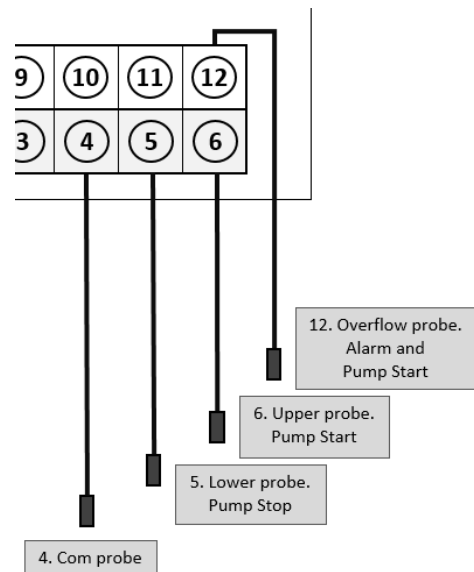

10. Drainage Mode – Control via Pump Float



Even when using pumps with floats permanently attached, to achieve maximum pump protection and control, use control floats or probes wired to the iProtect.



Disable the pump float by tying it in the upward (on) position.

The iProtect monitors current. While supplying power to the pump should the pump float switch the pump off the current drops to zero. The controller interprets this as less than the underload response value. (Default setting for dry run protection is 70% of normal run current)

This in turn causes a 'Dry Run' error, and the controller will initiate the dry-run recovery time countdown before attempting to start the pump again. (Default setting 30 min Parameter 004)

If the installer's preference is to use the float attached to the pump as the method of pump control, terminals 4, 5 and 6 must be bridged AND the dry run parameter 009 set to 0%



With the dry run parameter inactive the controller still provides protection against overload, locked rotor, under voltage and over voltage conditions. Additional benefits to the user are the anti-seize function, accumulated run time and the last 5 error record.

Connecting an external alarm device

Connection of an external alarm device directly to the iProtect is not currently supported.

11. Drainage Mode – LCD running state images

Pump calibration: (see pg 5)

Switch to manual mode   10 sec.

Start the pump 

Allow pump to reach a stable power.

Press  to store. Press  to exit.



There is no water at the source.

The pump will not run.

Related to  als 4, 5 and 6

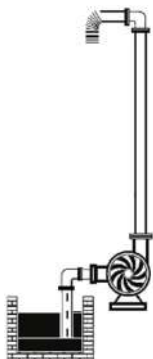

There is sufficient water at the source for the float or probes to send a run state signal

The pump starts and runs.

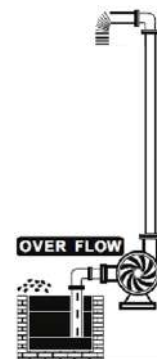

The controller is receiving a high level signal. The alarm will sound.

The pump will run if the controller is in Auto mode

Related to terminals 10 and 12

Ensure the controller is set to AUTO MODE when finished

12. Transfer Mode - Electrical Connections; floats or probes

The controller is rated IP54. It should be installed vertically where it has excellent ventilation away from direct sunlight or exposure to adverse weather. Installation inside a separate open fronted enclosure is suggested.



Any electrical alterations or additional connections should be carried out by a suitably qualified technician. Ensure suitably rated circuit breakers are installed.



Isolate the controller before opening the cover to access the low voltage circuit connections.

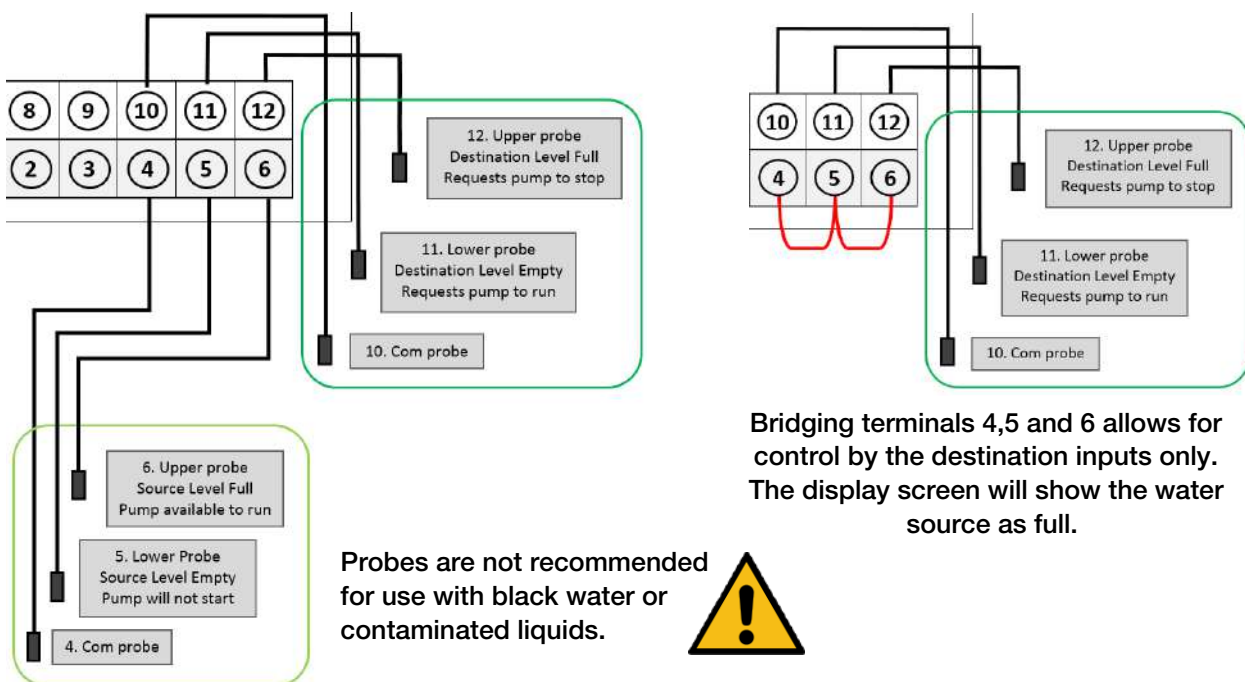
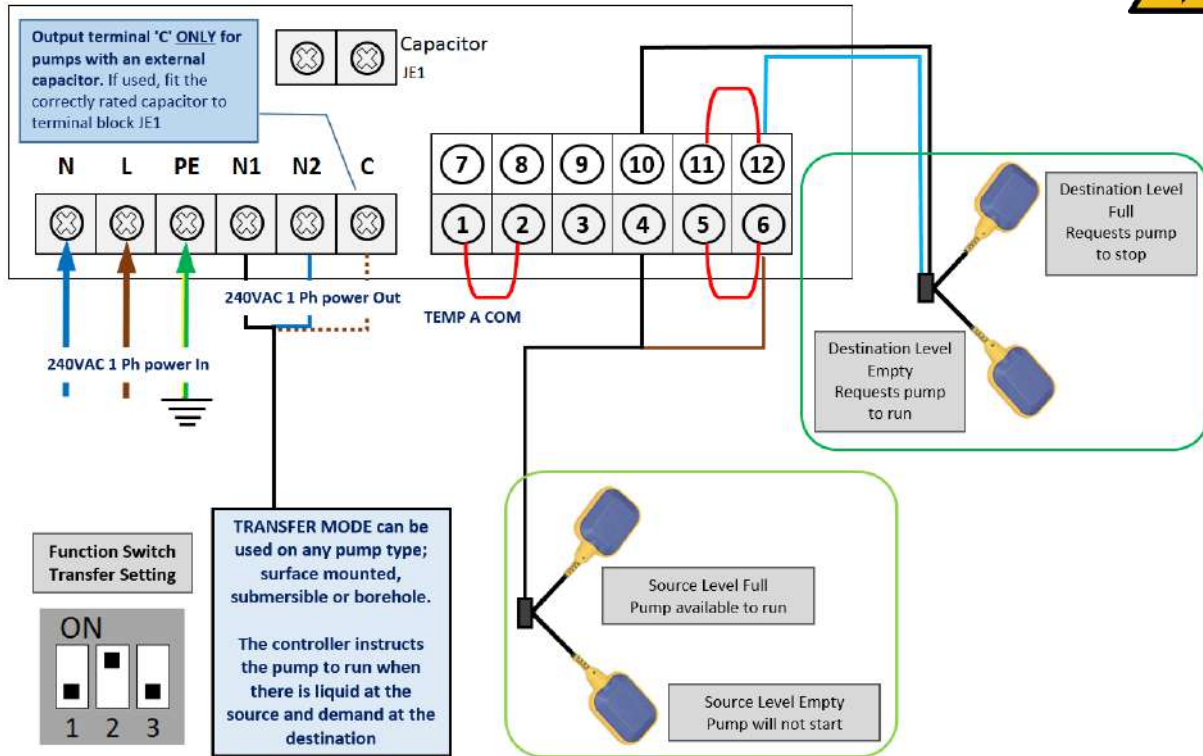

13. Transfer Mode - LCD running state images

Source liquid is below the low-level setting.

The pump will not run.

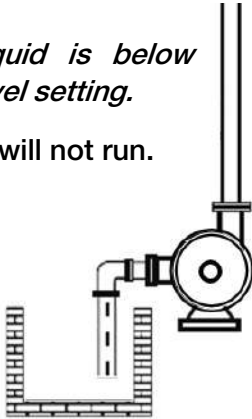

Pump calibration: (see pg 5)



Switch to manual mode

AUTO	STORE
MANUAL	SET

10 sec.

Start the pump

START

Allow the pump to reach a stable power.

Press

STORE
SET

 to store. Press

AUTO
MANUAL

 to exit.

Source liquid is above the high-level setting

Pump available to run

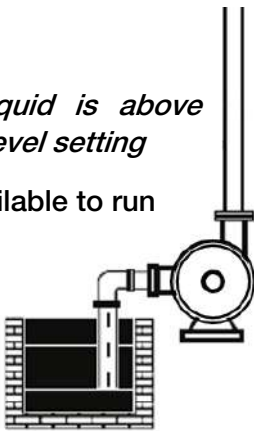

The iProtect has a reliable automatic stop function against pump dry-run.

When used with pumps where it is inconvenient to install source floats or probes, the installer can fit jumpers between terminals 4,5 and 6.

Destination liquid below the low-level setting.

If there is sufficient liquid at the source the pump will start

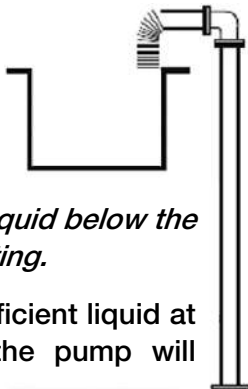

Destination liquid is above the high-level setting.

The controller will turn the pump off

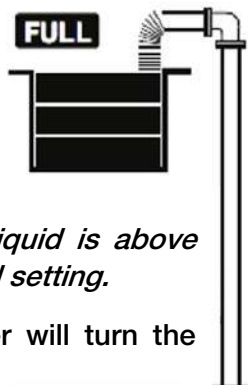

Ensure the controller is set to AUTO MODE when finished

14. Boosting Mode - Electrical Connections; floats or probes

The controller is rated IP54. It should be installed vertically where it has excellent ventilation away from direct sunlight or exposure to adverse weather. Installation inside a separate open fronted enclosure is suggested.

Any electrical alterations or additional connections should be carried out by a suitably qualified technician. Ensure suitably rated circuit breakers are installed.

Isolate the controller before opening the cover to access the low voltage circuit connections.

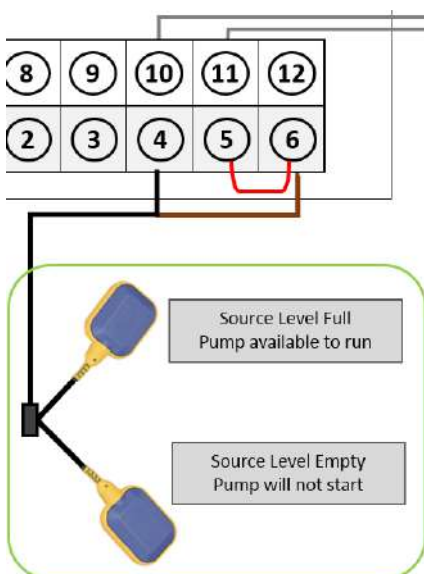
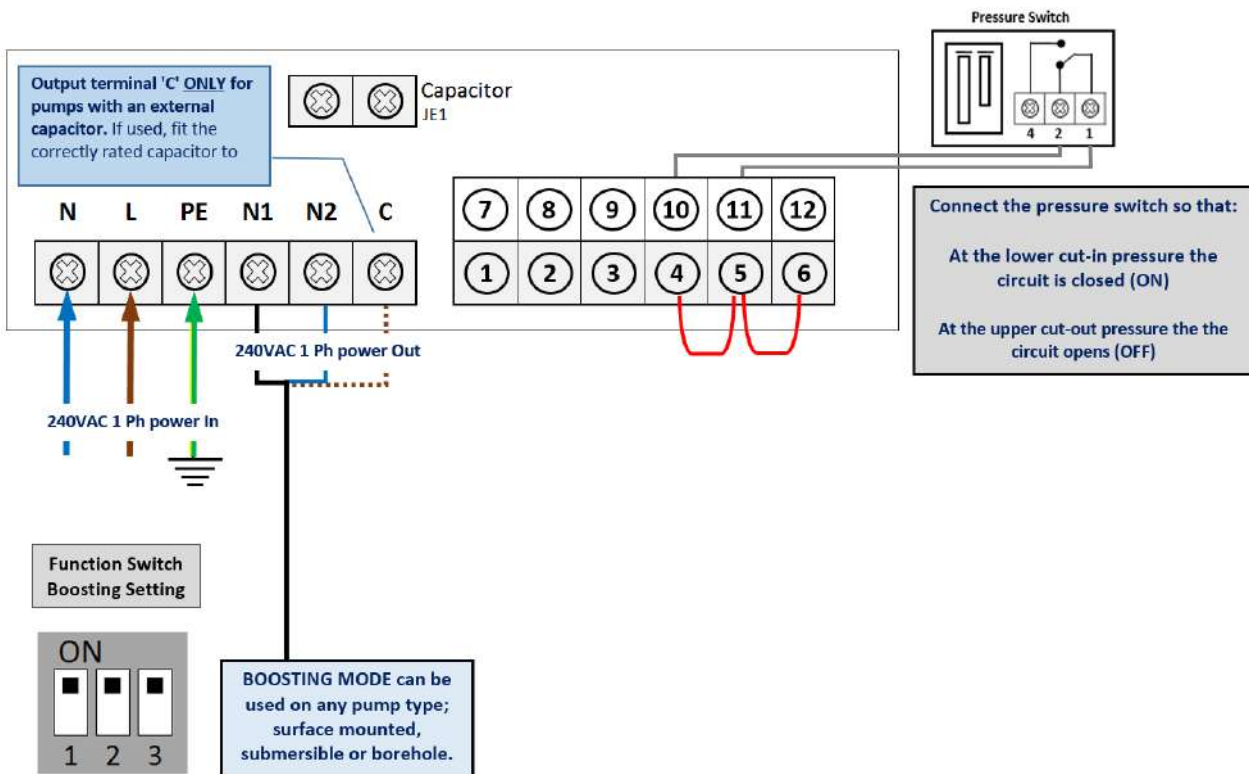

Fitting floats or probes to register the pump inlet source liquid level will achieve the maximum protection against pump dry-running.

The under-load function of the iPROTECT also acts as a reliable automatic stop function against pump dry-running. Jumpers can be fitted between terminals 4,5 and 6 if preferred

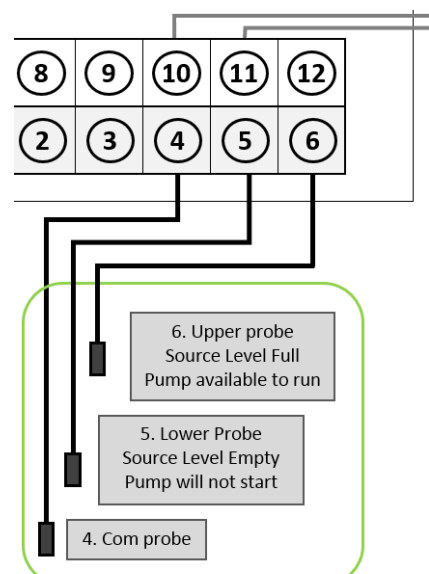

15. Boosting Mode - LCD running state images

Source liquid is below the low-level setting.

The pump will not run.

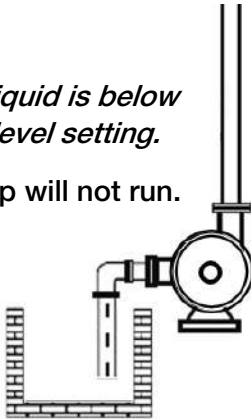

Source liquid is above the high-level setting

Pump available to run

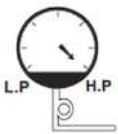
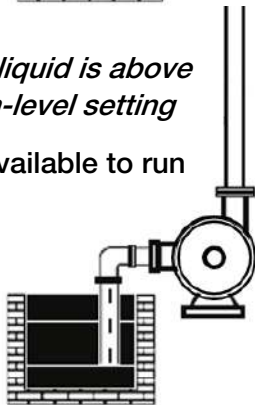

The Pressure switch is registering line pressure above the cut-out pressure. The switch circuit is open

If there is sufficient liquid at the source the pump will start



The Pressure switch is registering line pressure below the cut-in pressure. The switch circuit is closed

If there is sufficient liquid at the source the pump will start

Pump calibration: (see pg 5)

Switch to manual mode

AUTO	STORE
MANUAL	SET

 10 sec.

Start the pump

START

Allow the pump to reach a stable power.

Press

STORE	SET
-------	-----

 to store. Press

AUTO	MANUAL
------	--------

 to exit.

When the iProtect is used in BOOSTING MODE and the pump is controlled by a pressure switch, ensure that a suitably sized pressure vessel is installed in the system.

A Pressure vessel sized properly and set with the correct pre-charge pressure is intended to prevent the pump from starting more than 30 times per hour (20 times per hour for bore pumps)

Pressure tank pre-charge should be set to 66% of full system pressure

In BOOSTING mode, terminals 10 and 11 are the main control inputs.

Circuit closed = ON. Circuit open = OFF.

The user can exploit this knowledge to control the pump with an external device such as a timer or connection to an irrigation control unit. A relay may be necessary.



Never connect 240V supply to control terminals 1 – 12 or to N1, N2 or C

Ensure the controller is set to AUTO MODE when finished

16. Bore Pumps - Connecting 2 wire and 3 wire bore pumps

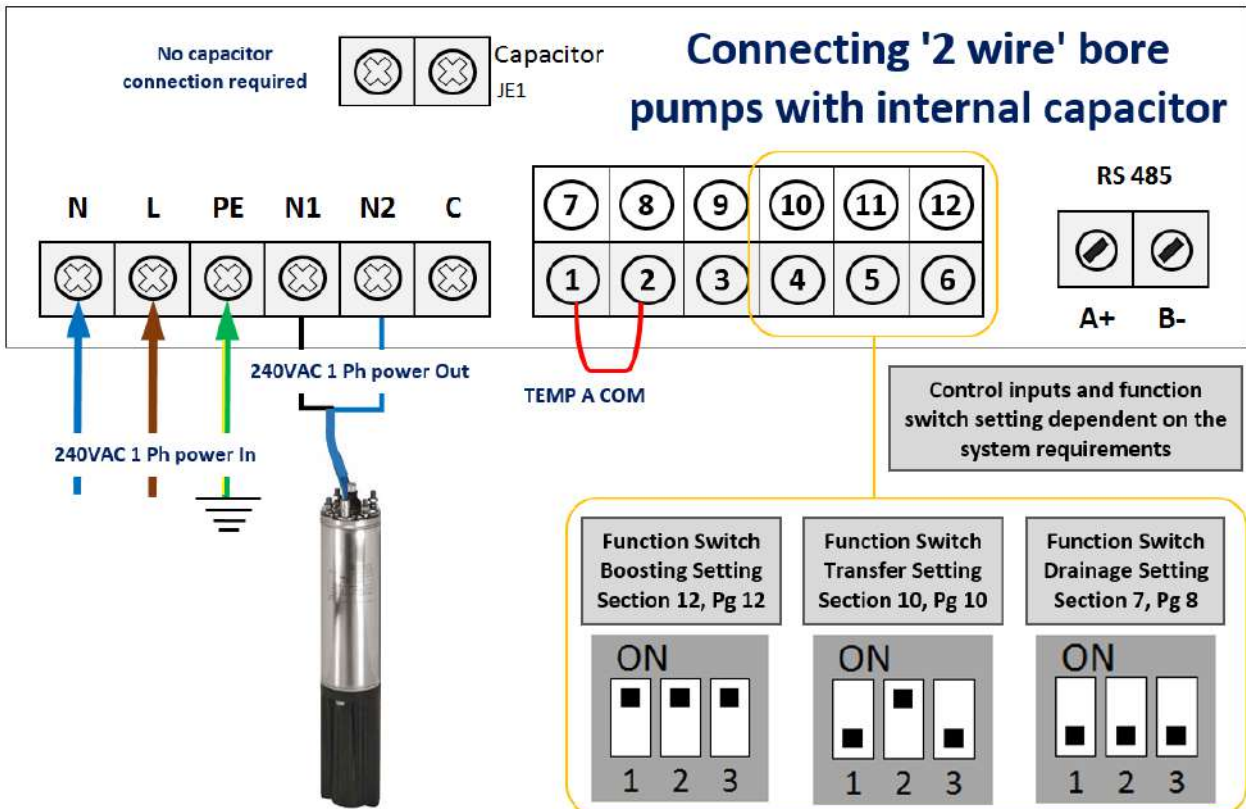
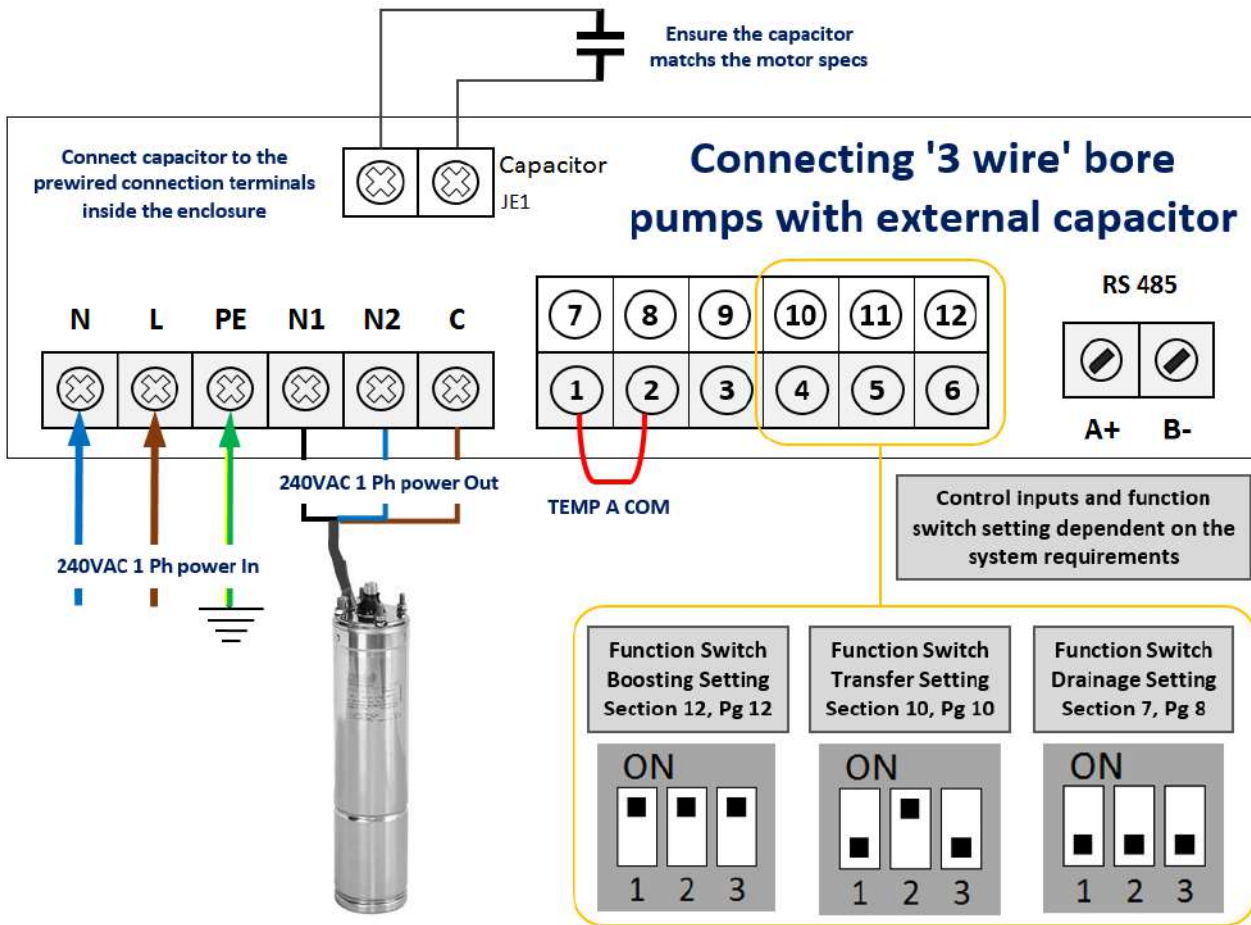

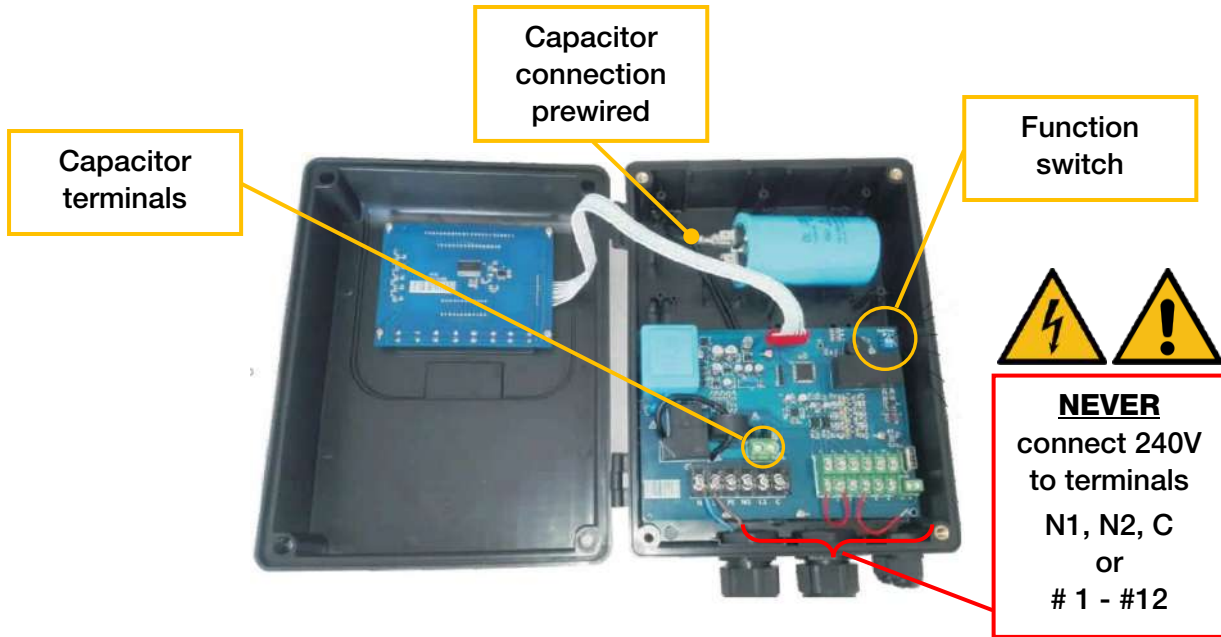

17. Communication link – RS485

The control panel has a communication interface. The wire communication distance is less than 1200 metres.

For those installations or environments which require a longer distance communication, users can use RS485 extender, wireless communication or GSM units.

Please contact [White International](#) for more information.

Technical data	
Physical interface	RS485 Bus Interface: asynchronous semi duplex
Data format	1 start bit, 8 data bit, 1 stop bit, no verify 1 start bit, 8 data bit, 2 stop bit, no verify Default: 1 start bit, 8 data bit, 1 stop bit, no verify
Baud rate	1200,2400,4800,9600 bps (default 9600bps)
Communication address	Setting range of controller address: 1-126 127: broadcast address, host computer broadcasting, slave machine response forbidden
Protocol type	MODBUS protocol (RTU)
Rated input voltage for SC	AC 240V/50Hz, single phase
Installation data	
Wire communication distance	1200 metres max by shield twisted pair cable (STP) for RS485 & CAN 5000 metres max by STP and RS485 extender
STP	STP-120U one pair 20AWG for RS485 & CAN
RS485 extender	5000 metres (9600bps)

15. Additional notes regarding calibration

The iProtect looks at the Power Factor of the power being used, not just the Voltage and Amperage. If the iProtect reads the Power Factor incorrectly it can be difficult to get the controller to accept its calibration.

The most reliable means of ensuring the unit is reading a stabilized power supply and that manually programmed parameters are saved correctly is to follow this procedure:

-

- ~~Reset iProtect (remove calibration)~~
- ~~Change to Manual mode~~
- ~~Start the pump uncalibrated and run until kW stabilizes~~
- ~~Turn the iProtect off~~
- ~~Turn the iProtect on~~
- ~~Auto Calibrate and save~~
- ~~Run the pump manually~~
- ~~Cycle the power (on/off) and check the values are as required.~~
- ~~Alter parameters manually as necessary.~~

18. Fault messages – possible causes and solutions

Fault Message	Possible Cause	Solutions
Flashing PUMP NO CALIBRATION Parameter 007 or perform the auto calibration sequence	Pump calibration has not been completed.	See Pg 6 for calibration instructions.
Flashing DRY RUN Parameter 004 and 008	Water level in the well/sump is below pump intake, pump stops running. Broken outlet pipe	iPROTECT will attempt to restart the pump every 30 minutes until water level restored.
Flashing OVER LOAD Parameter 005 and 009	Pump running amps greater than calibrated running amps, pump is in overload protection state. Pump damage, dragging impeller or bearing, possible clogging. Pump calibrated without water or with a nominal kW value	iPROTECT will attempt to restart the pump every 30 minutes until running amps restored to normal. Inspect and/or repair pump. Erase previous calibration and recalibrate with water.
Flashing PUMP STALLED Parameter 010	Pump running amps greater than 200% of calibrated running amps Pump Stalled protection is especially important for pumps with cutting or macerating mechanisms	Cut off power supply, inspect, repair or replace pump.
Flashing UNDER V Parameter 011	Voltage is lower than the calibrated voltage. The pump is in under voltage protection state.	iPROTECT will attempt to restart the pump every 5 minutes until normal voltage is restored.
Flashing OVER V Parameter 012	Voltage is higher than the calibrated voltage. The pump is in the over-voltage protection state.	iPROTECT will attempt to restart the pump every 5 minutes until normal voltage is restored.
Flashing REPEATED START	Pump starts more than 5 times per minute. <i>It is less likely that this could occur in drainage or transfer mode unless there is a wiring fault.</i>	Check pressure switch settings are correct for application. Check pressure tank pre-charge pressure and condition of diaphragm. Check the volume of sump is not too small.
Flashing OVER TEMP	The jumper on temperature protection terminals has been removed. Pump motor temperature high and pump thermal switch in open state (if connected).	Reinstall jumper on temperature protection terminals. Wait until pump motor temperature reduces. Investigate cause for Overheating.

19. Warranties – Terms and Conditions

This warranty is given in addition to the consumer guarantees found within the Australian Competition and Consumer Act 2010 (Cth) for goods purchased in Australia and the Consumer Guarantees Act 1993 NZ for goods purchased in New Zealand:



1) White International Pty Ltd / White International NZ Ltd (White International) warrant that all products distributed are free from defects in workmanship and materials, for their provided warranty period as indicated on the top or opposite side of this document. Subject to the conditions of the warranty, White International will repair any defective products free of charge at the premises of our authorised service agents throughout Australia and New Zealand if a defect in the product appears during the warranty period. If you believe that you have purchased a defective product and wish to make a claim under this warranty, contact us on our Sales Hotline on 1300 783 601, or send your claim to our postal address or fax line below and we will advise you as to how next to proceed. You will be required to supply a copy of your proof of purchase to make a claim under this warranty.

2) This warranty excludes transportation costs to and from White International or its appointed service agents and excludes defects due to non-compliance with installation instructions, neglect or misuse, inadequate protection against the elements, low voltage or use or operation for purposes other than those for which they were designed. For further information regarding the suitability of your intended application contact us on our Sales Hotline on 1300 783 601. If you make an invalid claim under this warranty, the original product will be sent back to you unrepai red.

3) This warranty refers only to products sold after the 1st January 2012, and is not transferable to another product type and only applies to the original owner, purchaser or end user, and is in addition to the consumer guarantees found within the Competition and Consumer Act 2010 (Cth) for goods purchased in Australia and the Consumer Guarantees Act 1993 (NZ) for goods purchased in New Zealand.

4) Our goods come with guarantees that cannot be excluded under the Australian Consumer Law. You are entitled to a replacement or refund for a major failure and for compensation for any other reasonably foreseeable loss or damage. You are also entitled to have the goods repaired or replaced if the goods fail to be of acceptable quality and the failure does not amount to a major failure. 2 YEAR WARRANTY

5) To the fullest extent permitted by law, White International excludes its liability for all other conditions or warranties which would or might otherwise be implied at law. To the fullest extent permitted by law, White International's liability under this warranty and any other conditions, guarantees or warranties at law that cannot be excluded, including those in the Competition and Consumer Act 2010 (Cth), is expressly limited to: (a) in the case of products, the replacement of the product or the supply of equivalent product, the payment of the cost of replacing the product or of acquiring an equivalent product or the repair of the product or payment of the cost of having the product repaired, is at the discretion of White International or a 3rd party tribunal elected under the Competition and Consumer Act 2010 (Cth) for goods purchased in Australia and the Consumer Guarantees Act 1993 (NZ) for goods purchased in New Zealand; and

6) To the fullest extent permitted by law, this warranty supersedes all other warranties attached to the product or its packaging.

7) In the case of services, supplying the services again or the payment of the cost of having the services supplied again, is at the discretion of White International or a 3rd party tribunal elected under the Competition and Consumer Act 2010 (Cth) for goods purchased in Australia and the Consumer Guarantees Act 1993 (NZ) for goods purchased in New Zealand. 8) Our warranty commences from the date of purchase of the above-mentioned pumps. Proof of purchase is required before consideration under warranty is given.

Record your date of purchase in the space below and retain this copy for your records.

Date of Purchase**Model Purchased**



www.whiteint.com.au
www.whiteint.co.nz

1300 783 601
0800 509 506

Please always refer to our website for further technical information & new product innovations

Disclaimer: Every effort has been made to publish the correct information in this manual. No responsibility will be taken for errors, omissions or changes in product specifications.

© 2020 Copyright White International Pty Ltd

TM ® - WARNING: Please be aware that various brands & products depicted within this document are subject to trademark, patent or design registrations. Infringement of any intellectual property contained within this document without express written authority by the appropriate intellectual property holder may result in further legal action to be taken. For any queries regarding use of the contained information please feel free to contact White International Pty Ltd.