

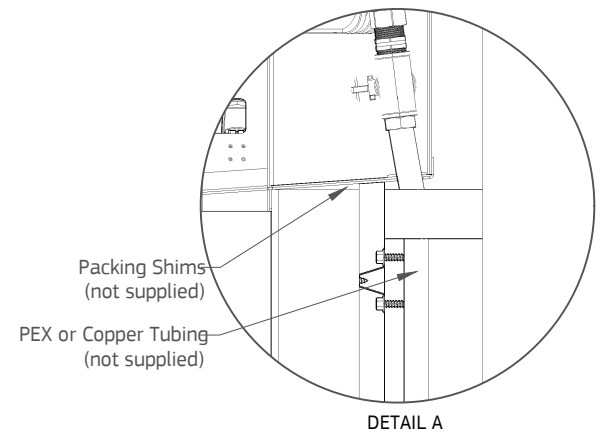

A4

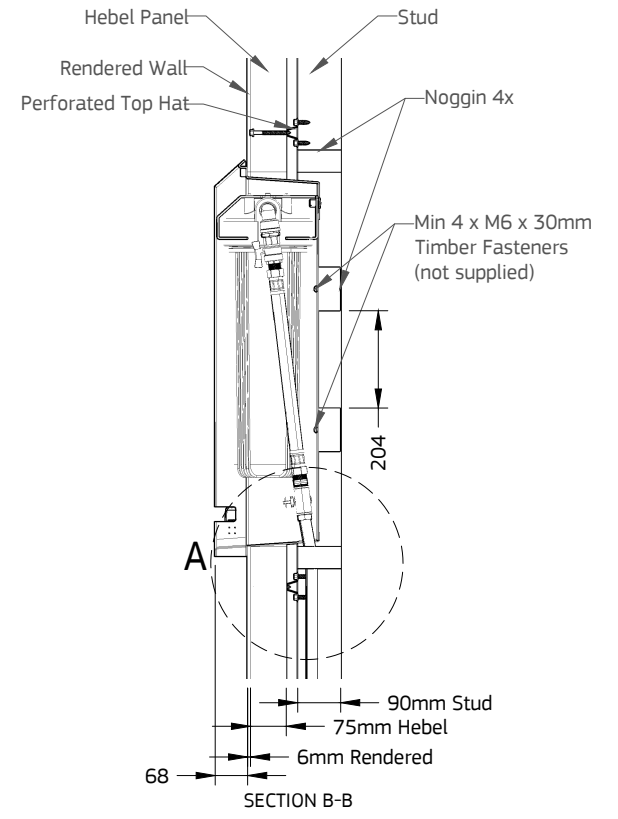
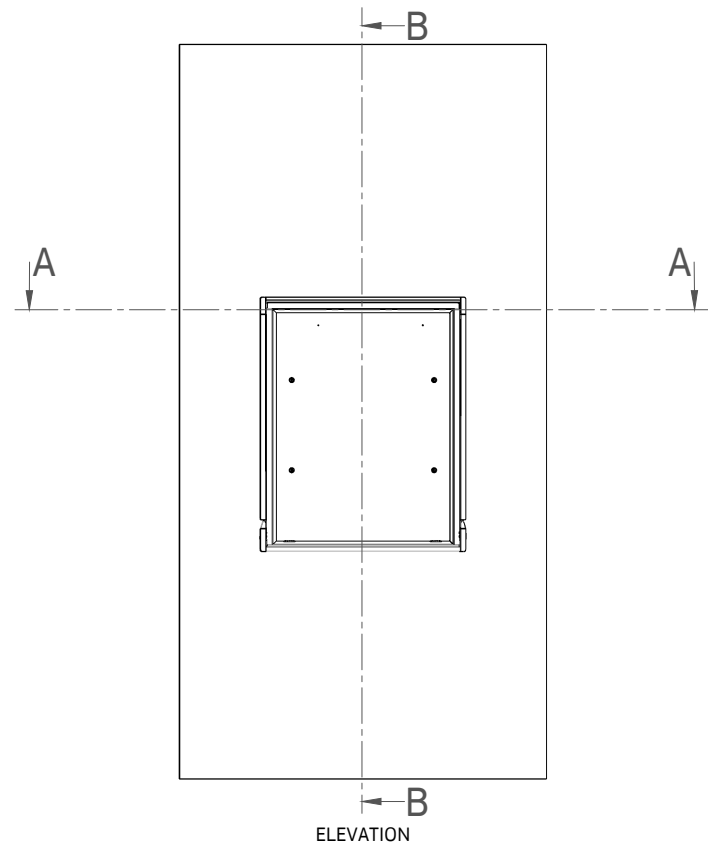
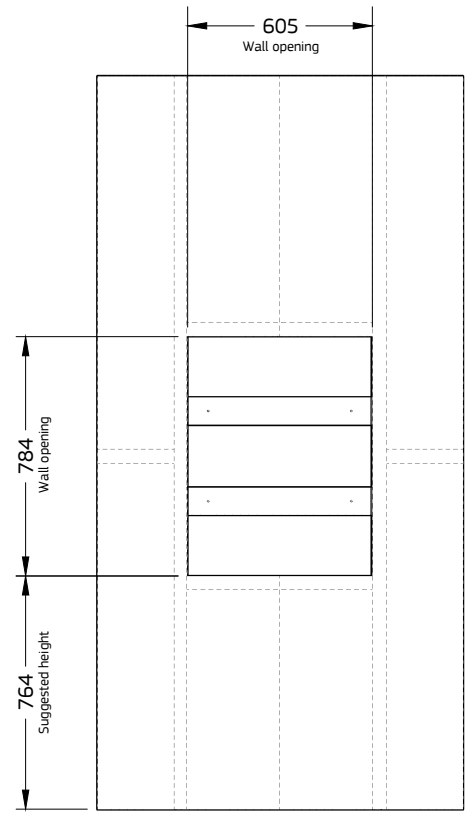
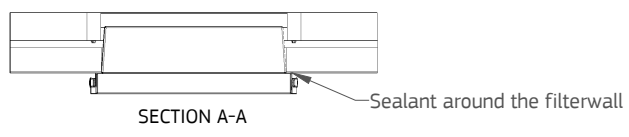
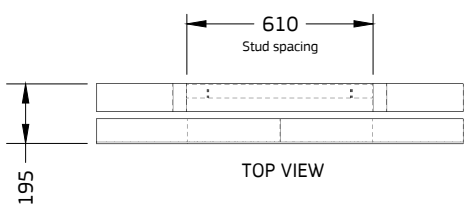

Note: All dimensions are in millimeters

Disclaimer:
Example installation shown. Ensure Australian building standard are met during installation.

DRAWN BY A.L.	DATE 16/02/2023	APPROVED BY S.M.	EMAIL ADDRESS marketing@puretecgroup.com	SCALE NTS	3RD ANGLE PROJECTION
 Puretec [®] PERFECTING WATER			NAME FILTERWALL INSTALLATION		A
			DESCRIPTION HEBEL PANEL 75MM		