

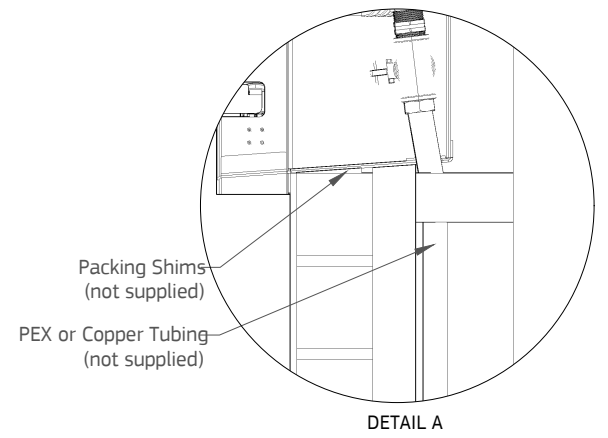

A4

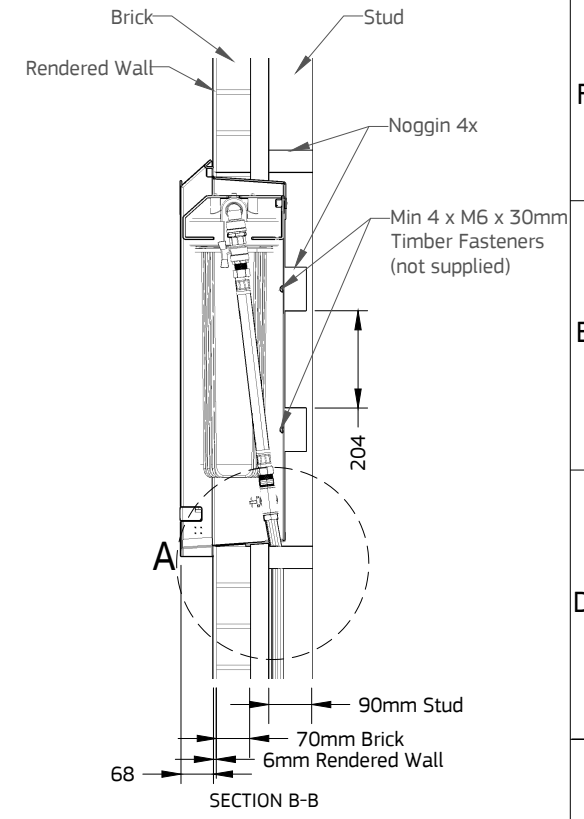
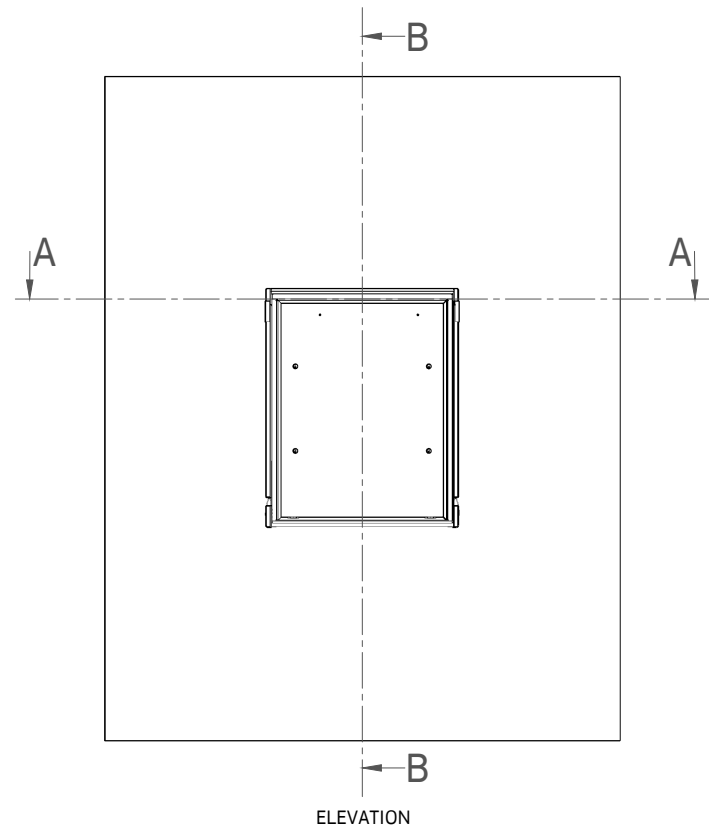
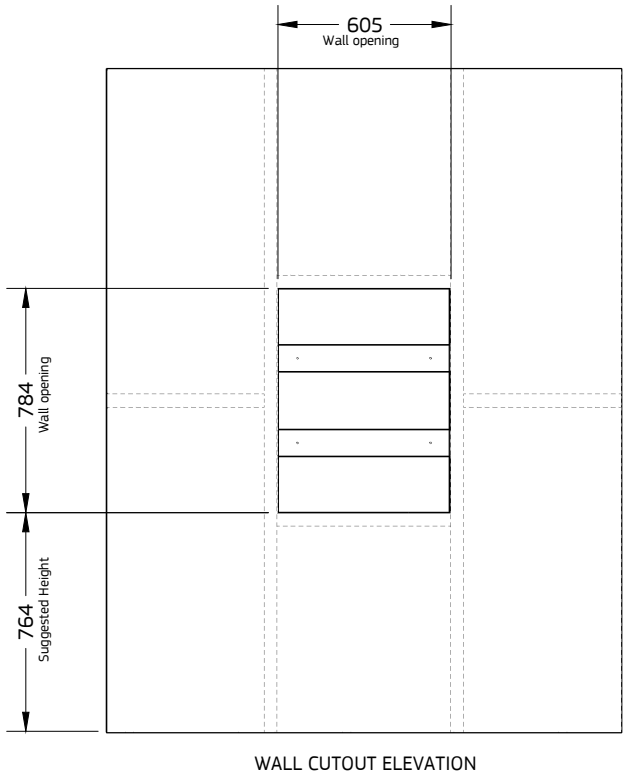
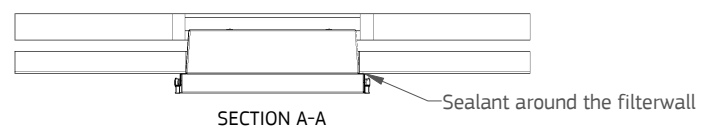
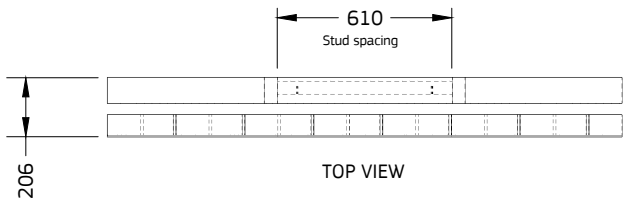

Note: All dimensions are in millimeters
 Disclaimer:
 Example installation shown. Ensure Australian building standard are met during installation.

DRAWN BY A.L.	DATE 07/03/2023	APPROVED BY S.M.	EMAIL ADDRESS marketing@puretecgroup.com	SCALE NTS	3RD ANGLE PROJECTION
 Puretec PERFECTING WATER			NAME FILTERWALL INSTALLATION		
			DESCRIPTION 70MM RENDERED BRICK WALL (Option 2)		