

USER MANUAL

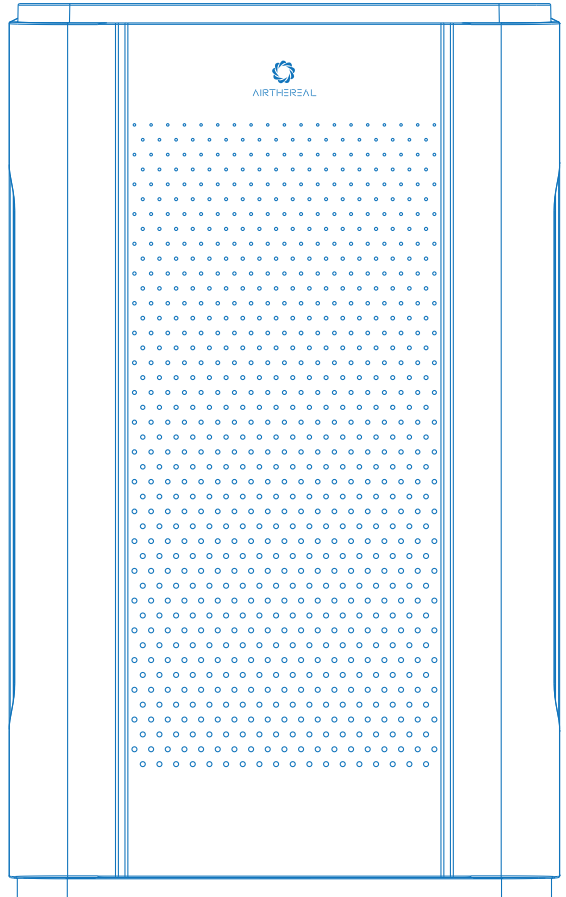

AIRTHEREAL

Pure Morning APH320 HEPA AIR PURIFIER



READ AND SAVE THESE INSTRUCTIONS

CONTENTS

COMPONENTS	2
SPECIFICATIONS	3
IMPORTANT SAFETY INSTRUCTIONS	4
INSTALLATION INSTRUCTIONS	5
OPERATION	6
MAINTENANCE	8
CLEANING	9
TROUBLESHOOTING	11
WARRANTY	12

COMPONENTS

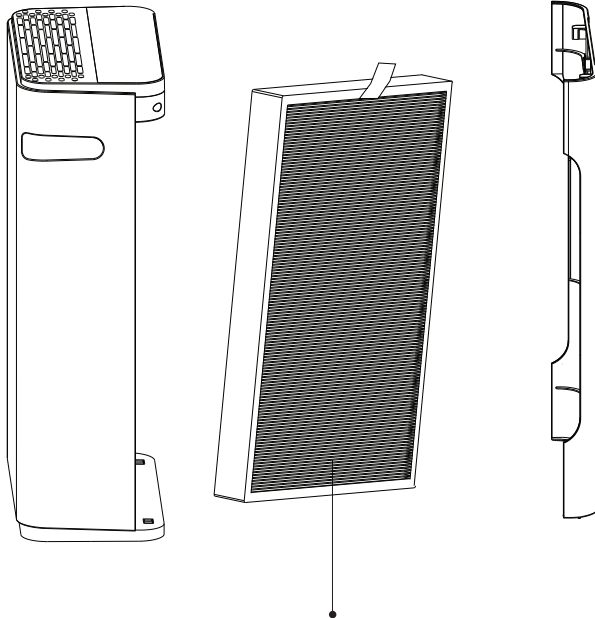
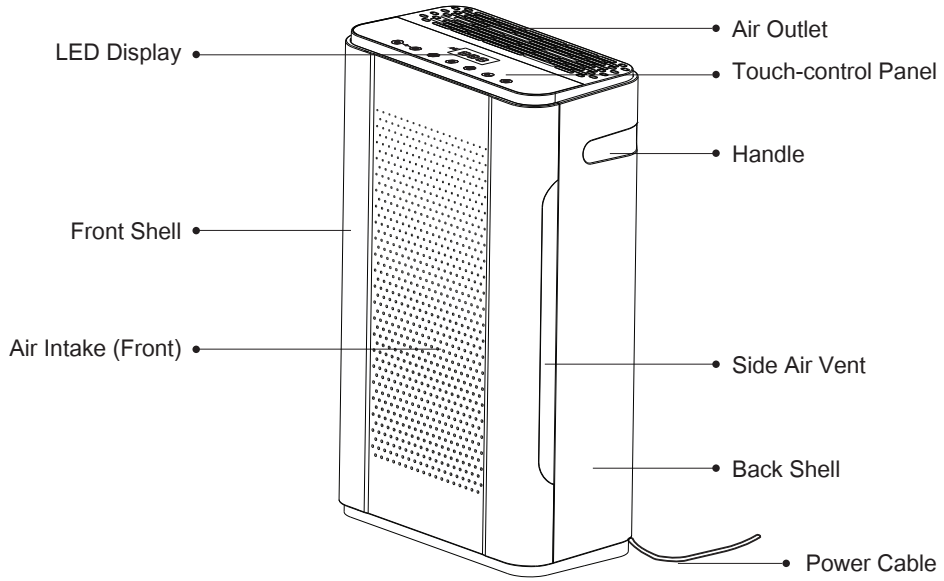

Medical Grade H13 True HEPA Filter

SPECIFICATIONS

Model	APH320
CADR	188 CFM (320 m ² /h)
Power Supply	AC 120 V
Standby Power	2 W
Rated Power	77 W
Dust Sensor	Laser PM2.5 Particle Sensor
Filter Structure	Pre-Filter, H13 Class True HEPA Filter, Activated Carbon Filter
UV Light	UV-C LED
Wavelength	270-275 nm
Bulb life	Approx. 50,000 hours
Noise Level	22-46 dB



OZONE DENSITY about HEPA AIR PURIFIER

This product complies with the maximum allowable concentration of ozone of 0.050 parts per million by volume (ppmv) in a 24-hour period.

The Health Canada Guideline 2010 recommends that the maximum exposure limit, based on an averaging time of 8 hours, is 0.020 ppmv or less when tested in a sealed, controlled room approximately 30 m³.

IMPORTANT SAFETY INSTRUCTIONS

IMPORTANT:

Please read and comply with all of the instructions and warnings in the manual before using. Failure to comply with the instructions and warnings provided herein may result in inaccurate results and/or damage to the product itself.

General Safety

Only use this air purifier as described in this manual.

- Ensure the plug fits properly into an AC power outlet.
- When not being used, turn the air purifier off and disconnect it from its power source by unplugging from the electrical outlet.
- DO NOT operate the unit if its cord or plug is damaged. It may result in damage to the unit or injury. It must be replaced by the manufacturer or other qualified person so as to avoid all risks.
- NOT recommend using an extension cord. If necessary, the extension cord should be same size as the original one.
- Thoroughly dry your hands before operation.
- DO NOT immerse air purifier in water or liquids. It may result in damage to the appliance, electric shock, or fire.
- DO NOT use the air purifier outdoors. This appliance is designed for indoor use only.
- DO NOT use the air purifier in an enclosed space where flammable, combustible, or explosive gases are present.
- DO NOT use in an area where toxic vapors, flammable dust or oxygen tanks are present.
- DO NOT insert fingers or objects into the air outlet.
- Child supervision is required while the air purifier is on. Do not allow children to play on or near the air purifier.

Use & Care

- Always make sure to place the air purifier on a flat, level surface before operation.
- Always allow 15 inches (38 cm) of clearance on all sides of the purifier.
- DO NOT ROUTE CORD UNDER FURNITURE OR APPLIANCES. Do not run the power cord under carpeting. Do not cover cord with throw rugs, runners or similar coverings. Place the power cord away from high traffic areas.
- DO NOT sit on or place anything on top of the purifier.
- DO NOT place the air purifier near sources of heat, such as stoves, ovens, radiators or computers.
- DO NOT use this appliance with indoor smoke-type insect repellents or in places with oily residues, burning incense or chemical fumes.
- DO NOT open the back shell while the air purifier is on. It will automatically turn off the unit.
- Always unplug the appliance from the power supply before servicing.
- DO NOT clean the appliance with water or any other liquid to avoid electric shock or injury.
- DO NOT attempt to repair this device in any way or use any replacement components or parts to modify the air purifier. Contact Customer Support immediately if your appliance is no longer working.
- Only use Airthereal Pure Morning APH260 replacement filters for this unit.
- If you experience any problems while operating the air purifier, refer to the Troubleshooting section in the manual. If the problem is NOT solved, contact Customer Support.
- If the unit is damaged or NOT functioning properly, discontinue use and contact Customer Support.

INSTALLATION INSTRUCTIONS

1. Open the front shell of the air purifier and unwrap the plastic package of the HEPA filter.

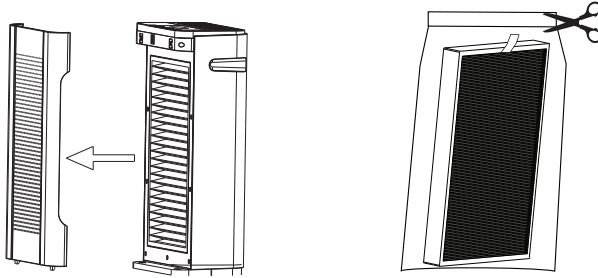

2. Reinstall the HEPA filter. Make sure the pull-tab is facing outward. Then install the front shell.

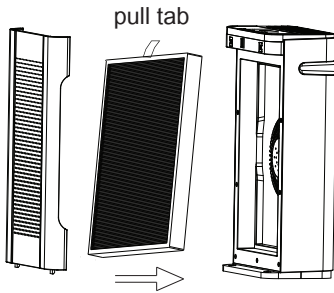

NOTE: If the front shell is not installed properly, it will not power on.

3. Place the air purifier where desired with at least 15 inches of open space around all sides of the purifier.

Place at least 15 inches away from TVs, radios, and other electronic products. Electromagnetic interference from certain electronics may cause product malfunction. Only use the unit on the firm and flat surfaces. Flimsy or slanted surfaces may result in abnormal noise and vibrations.

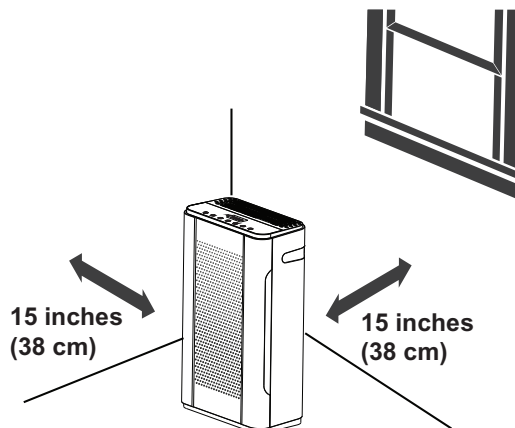

OPERATION

1. Insert the power cord into an electrical outlet.

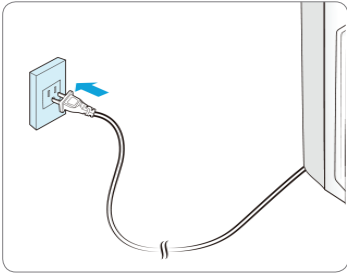

WARNING

Follow these instructions to reduce the risk of serious injury or death and to reduce risk of damaging the unit.

Follow these instructions to reduce the risk of serious injury or death and to reduce risk of damaging the unit.

Please make sure the operating voltage is the same as parametric label.

For American and Canadian users, our product will equipped with a POLARIZED AC PLUG that will fit into the power outlet only one way. If the plug does not fit fully into the outlet, reverse the plug. If it still does not fit, contact qualified personnel to install the proper outlet.

2. Touch-control panel Introduction

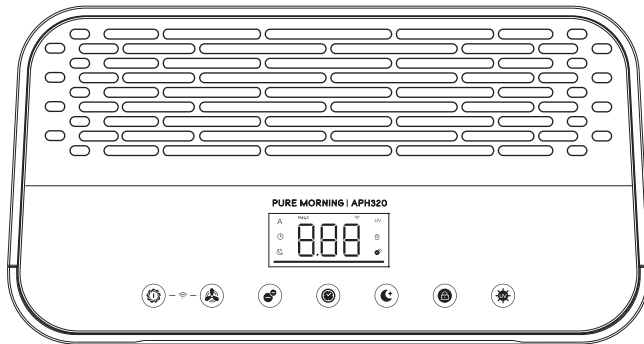

Power Button

- Press the button to power on.
- The Auto mode will automatically turn on when the unit is first powered on.
- The PM2.5 indicator shows the real-time PM2.5 value. After powering on, it takes about 15 seconds to activate the PM 2.5 Indicator. The air quality indicator will illuminate and display the real-time PM2.5 value and corresponding air quality indicator color.

PM2.5 ($\mu\text{g}/\text{m}^3$)	Levels of Health Concern	AQI (EPA of USA)	Fan Speed
0.0-12.0	Good	0-50	Low
12.1-35.4	Moderate	51-100	Medium
35.5-150	Unhealthy	101-200	High

Instant PM2.5 value is one of the core references for indoor air quality index (AQI). Regarding the AQI, working modes, and lights indicators, Airthereal APH320 Air Purifiers comply with EPA regulations.

For additional Information, please reference the United States Environmental Protection Agency (EPA): https://cfpub.epa.gov/airnow/index.cfm?action=aqi_brochure.index#particle

Fan Speed

Press to start air circulation. 3 fan speeds are available (low, medium, and high, corresponding with the values 1, 2, and 3 on the LED Display).

Each press will cycle between Auto → 1 → 2 → 3 → then start over with Auto.

WiFi

After the unit is powered on, please press and hold the POWER and FAN buttons simultaneously for 3 seconds to enter the connection mode. The WiFi icon will flash white, indicating that the unit is ready to connect. Once you have set up the connection, the WiFi icon will stop flashing and become illuminated in white.

Anion

Press to activate/inactivate the Anion Mode.

When the anion function is on, it becomes an air ionizer that uses high voltage to ionize air molecules. Anions are particles with one or more extra electron, conferring a net negative charge to the particle. It's used to eliminate the occurrence of airborne bacterial infections and to reduce static electricity buildup.

Timer

Press to switch to timer mode. (Timer can be set from 1-12 hours or to NO TIMER, corresponding to values 1-12 and 00 on the LED display.)

Sleep Mode

Press to turn on / off the Sleep Mode.

NOTE:

- Sleep Mode uses the lowest fan speed.
- When Sleep Mode is activated, the Air Quality Indicator is disabled.
- Tap the Fan Speed Button to exit Sleep Mode.

Child-Lock

Press and hold the Child-Lock button for 5 seconds to Lock and unlock.

UV-C Light

Press to activate/inactivate the UV-C Light mode.

UV-C refers to ultraviolet light with wavelengths between 200 - 280 nanometers (nm). It can be used for destroying harmful micro-organisms in food products and in the air.

Airthereal Pure Morning APH320 Air Purifier has passed ETL's stringent testing requirements. The UV-C light is rated at 50,000 hours, or slightly longer than 5 years. There's no need to replace the UV light under normal operating conditions.

MAINTENANCE

When the PM2.5 indicator light flashes red, it is a reminder to check and change the air filter.

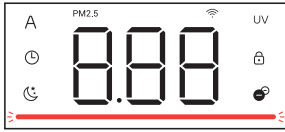

We recommend replacing the air filter every 6-8 months for optimal use.

It's time to replace the air filter when below signals appear:

- Increased noise
- Decreased airflow
- Clogged filters
- Presence of odors from the unit

Purchase a new Airthereal Air Filter Replacement:

Visit: www.airthereal.com

Search on Amazon: APH320 air purifier replacement filter / B089K1TMWS

Only use Airthereal Pure Morning APH320 replacement filters for this unit.

Replace the Air Filter

1. Power off and unplug the unit, then remove the front shell.

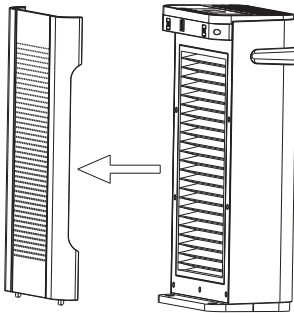

2. Remove the old filter by pulling the tab. Unwrap a new one.

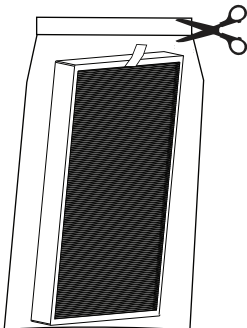

3. Install a new filter in the unit. Make sure the pull-tab on the filter is facing outward and then reattach the front shell.

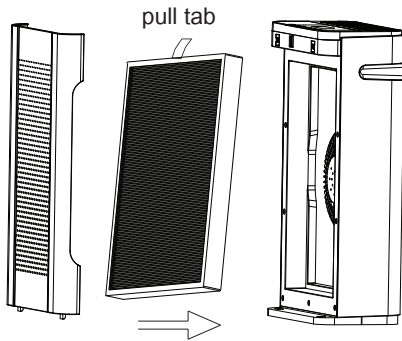

4. Power the unit on. Press and hold the button  &  simultaneously for 3 seconds to reset the replacement reminder.

Note: If the front shell is not installed properly the unit will not power on.

CLEANING

Unplug the power cord before cleaning.

The plastic shell should be cleaned with a soft, damp cloth. Add mild detergent as needed.

Remove the front panel and clean both sides of the air outlet with a vacuum cleaner to remove any dust.

For optimal maintenance, clean the unit every 2 months

TROUBLESHOOTING

Problem	Cause	Solution
No power or response.	Unit is not plugged into an electrical outlet.	Connect the plug to a powered electrical outlet.
	Outlet is not working properly.	Try plugging the air purifier into a different outlet.
	Front cover is not properly placed on the unit.	Properly replace the front cover as noted in the Getting Started section.
	Power cord is damaged.	Immediately discontinue use and contact Customer Support.
	Air purifier is defective or malfunctioning.	
Any faulty display of the LED numbers.	Auto Mode has just been turned on.	Allow the air purifier to run for 30S. They will change a stabilized status based on the detected air quality
	Unit is defective or malfunctioning.	Immediately discontinue use and contact Customer Support.
Unusual noise while operating.	Dirty filters.	Replace the air filters as instructed in the Replacing the Air Filters section on page 8-9.
	Filters installed improperly.	Properly place filter as noted in the Getting Started and Replacing the Air Filters sections (page 8-9).
	Foreign object inside the unit.	Immediately discontinue use and contact Customer Support. DO NOT attempt to open the air purifier.
	Flimsy or slanted surfaces resulting in abnormal noise and vibrations.	Place air purifier on hard, flat surfaces.
Significantly reduced airflow.	Not enough space around the unit.	Ensure that there is at least 15 inches (38 cm) between the unit and other objects.
Poor air purification quality.	Surrounding area exceeds the applicable area.	APH320 is applicable to 435 ft ² (40 m ²).
	Air inlet or outlet is blocked.	Remove objects that block the air inlet or outlet.
	Filter(s) not properly placed in housing.	Properly place filter as noted in the Getting Started and Replacing the Filters sections (page 8-9).

WARRANTY

Product Name	True HEPA Air Purifier
Model	Pure Morning APH320
Manufacturer Warranty Period	2 Years
For your own reference, we strongly recommend that you record your order number and date of purchase.	

TERMS & POLICY

Quality has always been Airthereal's top priority. For your 100% hassle-free shopping experience, Airthereal provides a **2-Year** manufacturer's limited warranty for APH320 Air Purifiers.

Internet information: airthereal.com/pages/warranty

What's covered?

Defects due to faulty materials and workmanship of the product.

What's NOT covered?

1. Damage caused by the owner when attempting to fix or altering the product by him or herself.
2. Damage caused by misuse, abuse, neglect, alterations, or unauthorized repair.
3. Natural depreciation.

Warranty Period

Warranty becomes effective since the date of original purchase and will last for two (2) years.

Who's covered?

This limited warranty is only effective for the original purchaser. It is NOT transferable.

How to request warranty services?

To obtain the benefit of this warranty, please leave a message online (<https://airthereal.com/pages/warranty>), or send an email to support@airthereal.com. Our customer service will get back to you within 24 hours.

What will Airthereal do?

1. Repair the item.
2. Replace the item if repairable.
3. Refund the item under certain circumstances.

ALL EXPRESSED AND IMPLIED WARRANTIES, INCLUDING THE WARRANTY OF MERCHANTABILITY, ARE LIMITED TO THE PERIOD OF THE LIMITED WARRANTY.



DISPOSAL

This product must not be disposed of via normal household waste after its service life but must be taken to a collection station for the recycling of electrical and electronic devices. The symbol on the product, the operating instructions or the packaging indicate such disposal procedures. The materials are recyclable in accordance with their respective symbols. By means of re-use, material recycling or any other form of recycling old appliances you are making an important contribution to the protection of our environment. Please ask your local council where your nearest disposal station is located.

FEDERAL COMMUNICATION COMMISSION INTERFERENCE STATEMENT FCC STATEMENT

This device complies with Part 15 of the FCC Rules. Operation is subject to the following two conditions:

1. This device may not cause harmful interference, and
2. This device must accept any interference received, including interference that may cause undesired operation.

NOTE: This equipment has been tested and found to comply with the limits for a Class B digital device, pursuant to Part 15 of the FCC Rules. These limits are designed to provide reasonable protection against harmful interference in a residential installation. This equipment generates, uses and can radiate radio frequency energy and, if not installed and used in accordance with the instructions, may cause harmful interference to radio communications. However, there is no guarantee that interference will not occur in a particular installation. If this equipment does cause harmful interference to radio or television reception, which can be determined by turning the equipment off and on, the user is encouraged to try to correct the interference by one or more of the following measures:

- Reorient or relocate the receiving antenna.
- Increase the separation between the equipment and receiver.
- Connect the equipment into an outlet on a circuit different from that to which the receiver is connected.
- Consult the dealer or an experienced radio/TV technician for help.

FCC Caution: Any changes or modifications not expressly approved by the party responsible for compliance could void the user's authority to operate this equipment.

FCC RADIATION EXPOSURE STATEMENT

This equipment complies with FCC radiation exposure limits set forth for an uncontrolled environment. End users must follow the specific operating instructions for satisfying RF exposure compliance. To maintain compliance with FCC RF exposure compliance requirements, please follow operation instructions as documented in this manual. This transmitter must not be colocated or operating in conjunction with any other antenna or transmitter. This equipment should be installed and operated with a minimum distance of 20 cm between the radiator and your body. The availability of some specific channels and/or operational frequency bands are country dependent and are firmware programmed at the factory to match the intended destination. The firmware setting is not accessible by the end user.

Always here to help you
www.airthereal.com

Keep Out Of Reach Of Children

Produced for: West Ryder Technology LLC
251 Little Falls Drive, Wilmington, DE 19808-1674, USA
EPA EST NO: 99066-CHN-1
support@airthereal.com



Made in China

V 20220629

FOR THE AIR WE CARE