

Please read the manual before using the product. The manual and carton contain important information, please keep them properly for later references. Failure to follow the instructions in the manual, it might be dangerous for your child.

In order to improve the product and quality, we may change the parts of structure, appearance, packing method, assembly method and function of the product without any notice. When there is any difference between the manual and the product, please subject to the actual product. We are sorry for any inconvenience.



# Hollicy

The assembly manual of  
battery operated car

**Model: SX2128**

Executive standard:

EN71-1

EN71-2

EN71-3













EN62115

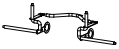

## WARNING:

Products should be assembled by an adult. Protective equipment should be worn. Not to be used in traffic. Not suitable for children under 3 years. Choking hazard- small parts. In unassembled state, contains potentially hazardous small parts. Please keep out of the reach of small children. Pay attention to the potential hazards of using the toy in areas other than private grounds.

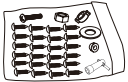
## PARTS LIST

PARTS NAME	PICTURE	QTY	PARTS NAME	PICTURE	QTY
Car body		1PC	Backrest		1PC
Wheel		4PCS	Engine cover		1PC
Rear axle		1PC	Front axle frame		1PC
Handle bar		1PC	Wheel cover		4PCS
Front bumper		1PC	Front motor		2PCS
MP3 player		1PC	Hardware bag		1PC
Charger		1PC	Manual		1PC

Disclaimer:

The pictures in the instructions are for assembly reference only.  
Please refer to the actual product.

Warning:

This product is not the vehicle for transportation, it should be used under adult guidance. Parents should ensure that children have taken the safety measures before use.

The toy should be used with caution since skill is required to avoid falls or collisions causing injury to the user or third party.

## PRODUCT SPECIFICATIONS

Battery	12V7AH 12V14AH
Main material	PP
Suitable age	37-95 Months
Weight limit for the car	30kg
Product size	118*78*81.5CM
Packing size	99*55.5*53CM
Speed	3-8KM/Hour
Runtime	1-2 hours after charging for 8-12 hours, based on ride on conditions
Charger	Input AC 110-220V Output DC 12V-1000mA
Fuse	Auto-reset fuse

## Openable engine hood, convenient for battery maintenance

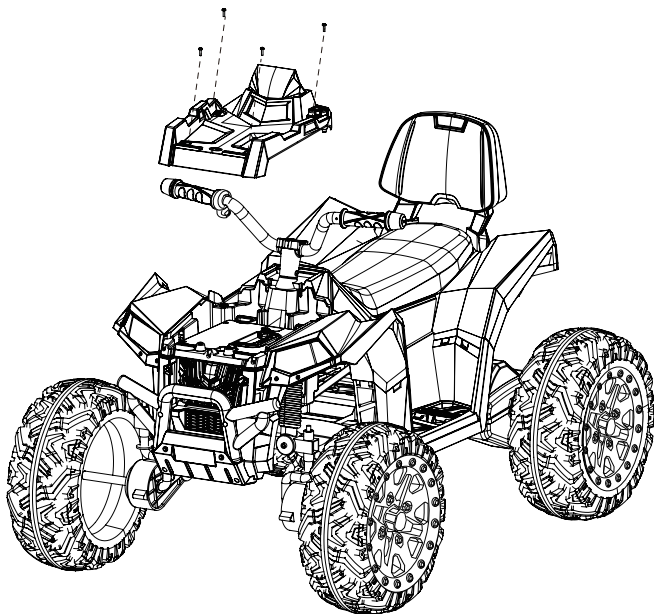

### Assembly instruction

- Car assembly should be done by the adults.
- Take care of small parts. To avoid choking hazard, keep children away while assembling. Children under 36 months are prohibited to use.
- Please count all the parts carefully before assembling and dispose the plastic bag properly. Children are prohibited from playing.

### 1. Shock absorber and rear axle assembly

Use knife or scissor to cut off the cable tie on the rear of the car body, separate the upper and lower parts. Use provided wrench tool to remove the screw and lock nut from the shock absorber, align shock absorber with iron loops on the car body, then insert the screw and secure with lock nut. Remove the nuts and washer from rear axle and insert the axle, make sure each side has equal clearance for the both of the rear wheels. Keep the nuts and washers for later use.

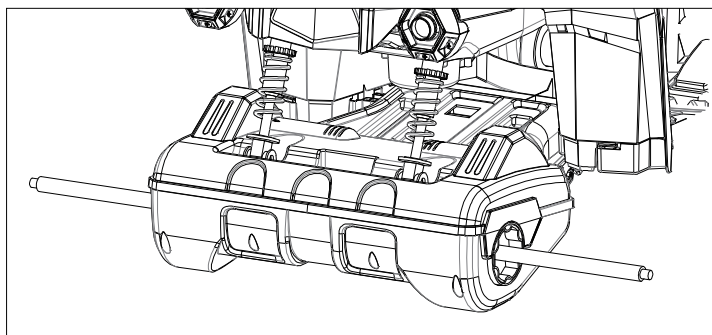
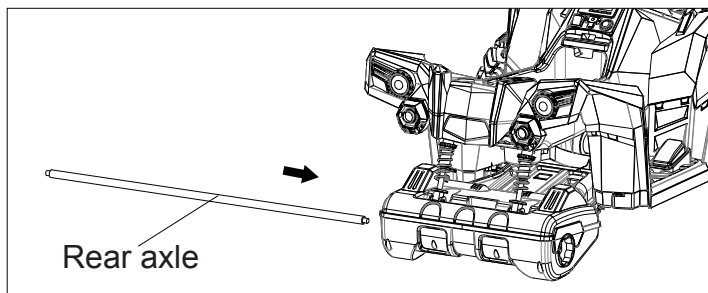
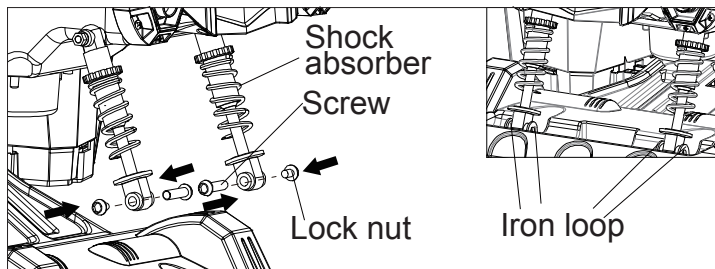

## 2. Power connection

Remove four screws on engine cover, open it and connect two red plugs from two wires.

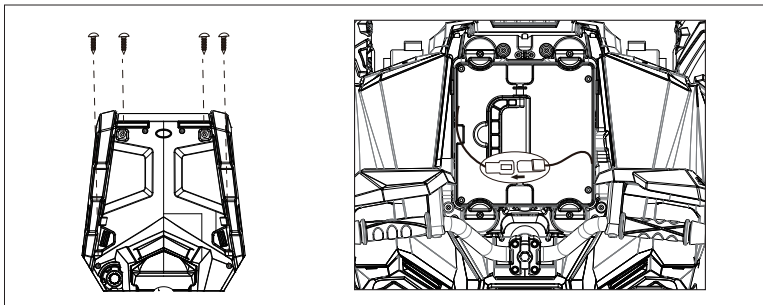

## 3. Steering rod and front axle frame assembly

Insert steering rod through the car body, disassemble the nuts and washers on two steel bars of front axle frame, align two steel bars with the holes on square steel tube, align the end of the steering rod with the loop on the front axle frame, insert the disassembled washer on two steel bars and secure with nuts, place a washer onto steering rod and secure with cotter pin.

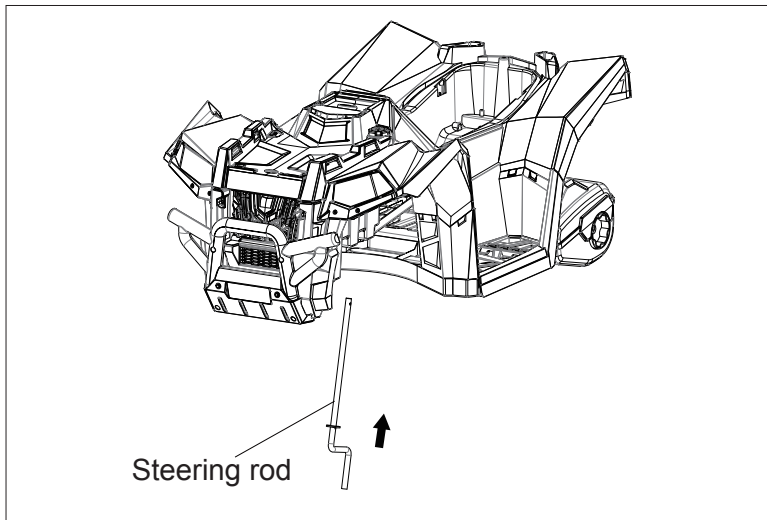

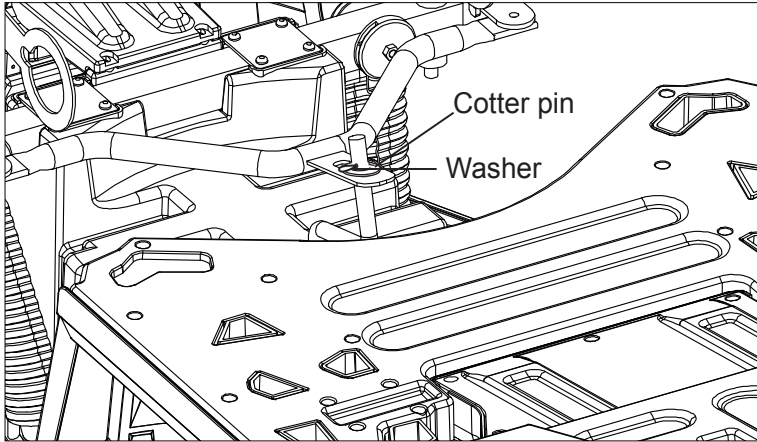
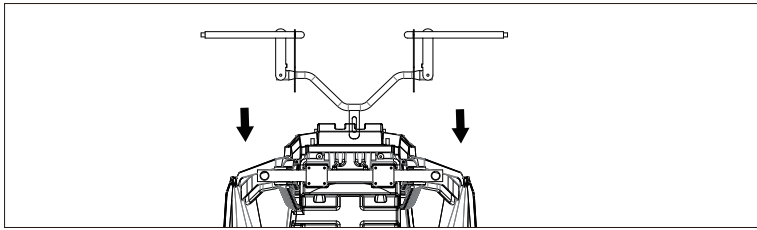
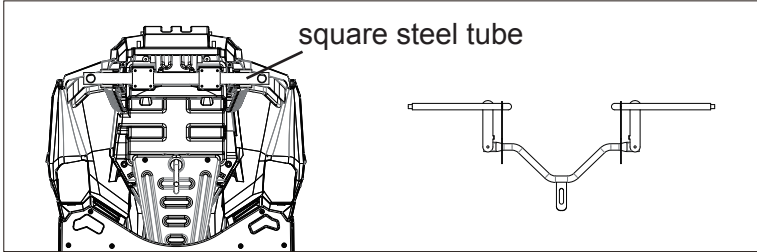
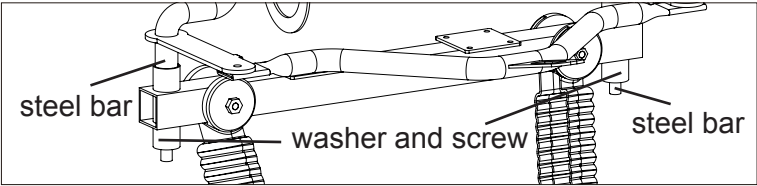

#### 4. Motor assembly

Remove the washers and lock nuts from the front axle, insert the motor to the front axle, connect the two plugs from motor and car body.

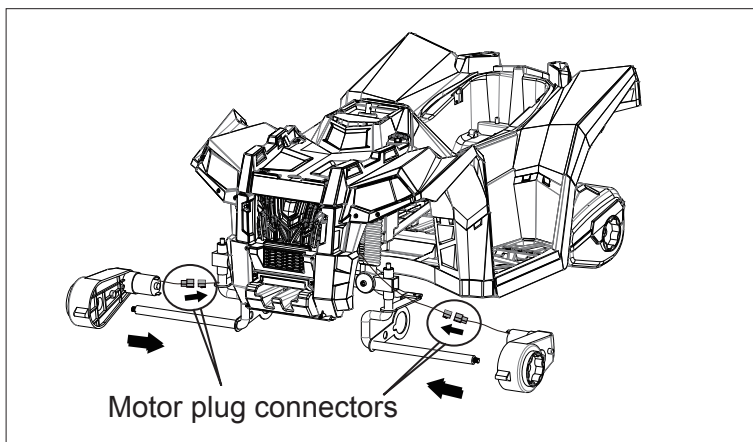

#### 5. Front wheel assembly

Attach the front wheel onto front axle, insert the washer, use the provided plastic wrench to tighten the lock nut. While applying pressure lock wheel cover into grooves in the wheel.

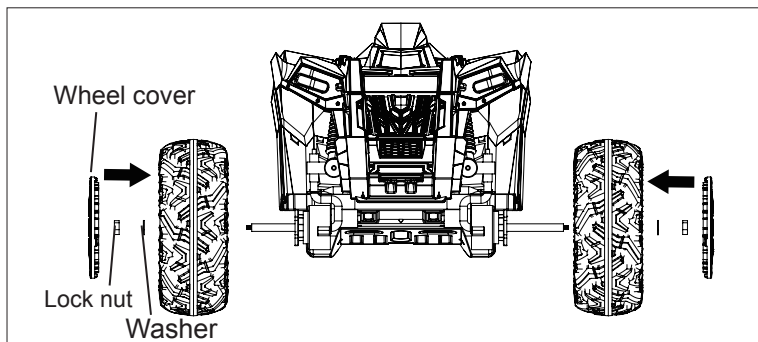



## 6. Backrest assembly

There are two grooves on the back of the seat, insert the backrest to the grooves and push into place.

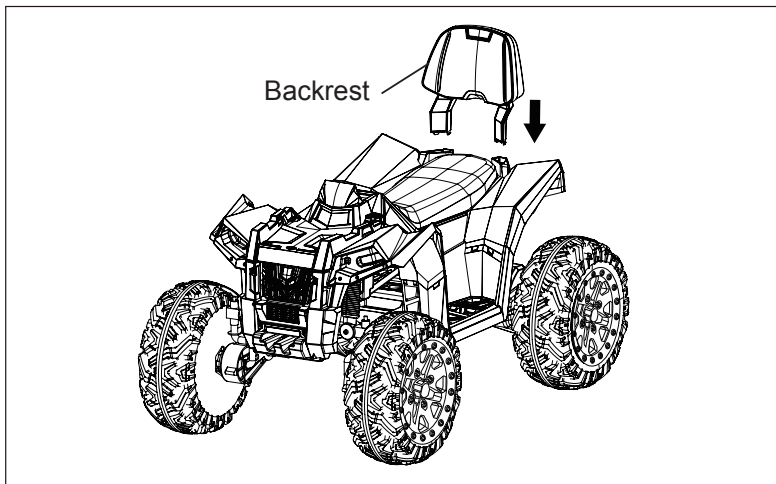

## 7. Rear wheel assembly

Attach the rear wheels onto the rear axle, both wheels must be attached at the same time. While attaching the wheels, place the washers and nuts which are disassembled in the step 1 onto the axle. Use two provided plastic wrenches and tighten both lock nuts together. While applying pressure lock wheel covers into grooves in the wheel.

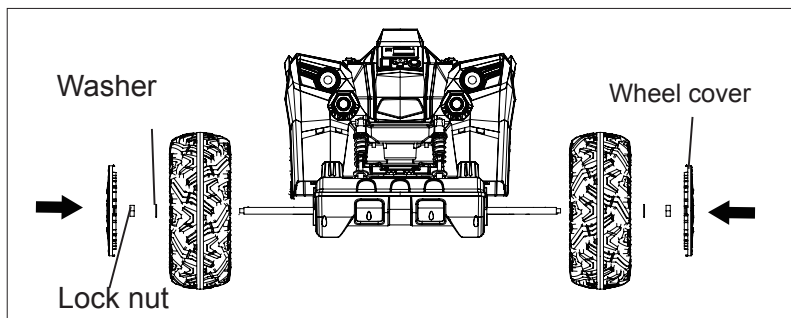

### 8. Front bumper assembly

Attach the front bumper with the car body and secure it with four screws.

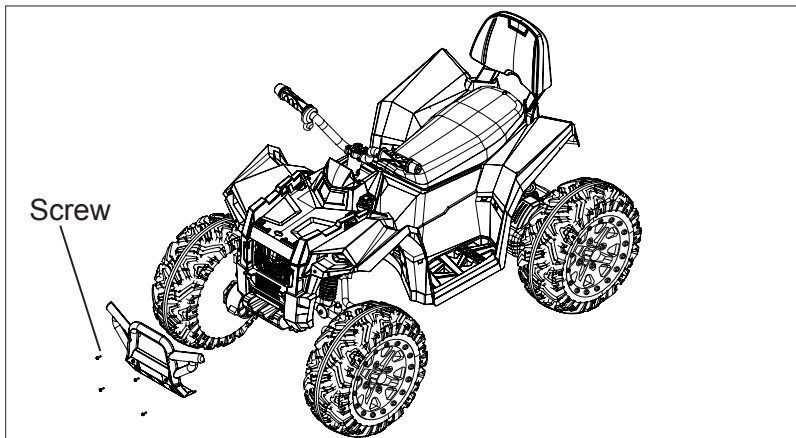

### 9. Handle bar assembly

Insert handle bar to the car body, align the holes on handle bar and steering rod, fasten them with screw and nut.

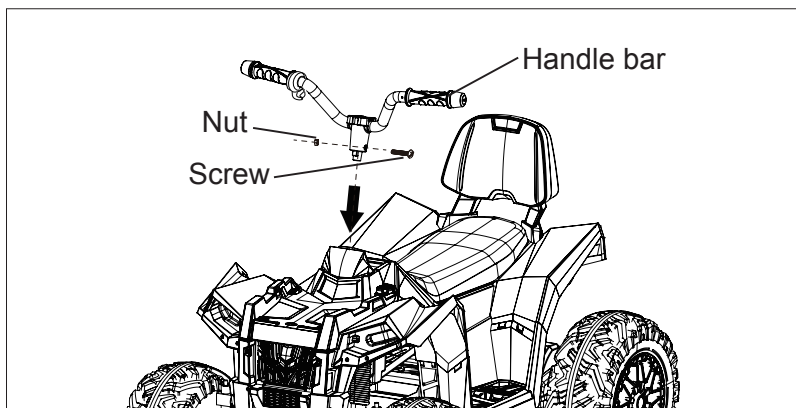

## FUSE

This car has a auto-reset fuse, if the car stops suddenly during driving, it is mainly caused by instantaneous current exceeds, which makes the fuse to trip. Then just stop operating for about 8 seconds, and this fuse can be reset. Then turn on the power switch again. In order to avoid the fuse tripping and cutting off power supply, please pay attention to the following matters.

This product can't be overloaded, the maximum load is 30kgs.

Don't drag anything behind the product.

Don't let the water or other liquid into the batteries and other electrical components.

Don't change the circuit system and structure of the product.

## SECURITY WARNING

1. The installation and charging of vehicle should be under adult supervision at all times.
2. This product is limited to the children from 37 to 95 months, 30 kg weight limit.
3. This product is ideal for driving on a hard flat surface.
4. It is strictly prohibited in the streets or the road, pot holes, and slopes.
5. Avoid driving in the sand or grass or uneven ground.
6. Children should be given full instructions on operation of the car. Improper operation can cause damage or accidents.
7. While children are driving, it is parents' duty to supervise at all time to avoid accidents.
8. Avoid driving in the rain or flooded pathways. By doing so it can damage the motor, circuit and other electrical equipments.
9. Battery charger should be regularly inspected by parents to insure that the wires, plugs, crusts and other components are not damaged. Please stop using if any damage is found, until it is completely restored.
10. In order to ensure product life and safety, avoid damage to the charger, battery or electric circuit, the car must use the default configuration of a dedicated charger and power supply.
11. Rechargeable batteries should be removed from the toy before charging.

12. When not using the of product, please cut off the product power, and keep all the switch to "stop" or "off" position.

13. The charger provided is not a toy. It is to be kept away from children.

14. Strictly prohibit using the non-manufacturer provided parts.

15. This product is made of PP material mainly, and the safe using time is two years.

## **USAGE DIRECTION**

1. Before using it, make sure that all the following works are done.

- Step described in accordance with the instructions to complete the installation of the car, the battery plug-in has been connected, the power supply has been switched on.

- Make sure that all the positions which need the screws are fixed tightly.

- Parents or guardian should ensure that children have taken the safety measures before using.

To reduce the risk during using, pay attention the followings:

When driving the car, child should sit on the car seat.

Adults or parents should take more care and guidance when child driving and can't leave away.

Pay attention to the driving environment and driving on the hard flat surface, not the unsafe environment.

For example:

a. The trenches, the riverside, slope or uneven ground;

b. Road or other places for driving and walking;

c. The obstruction which is easily hitting and causing injury;

d. Other unsafe zones.

To avoid accidents, please use only in daytime or bright place, avoid using under low visibility.

## 2. Operating(function reference diagram)

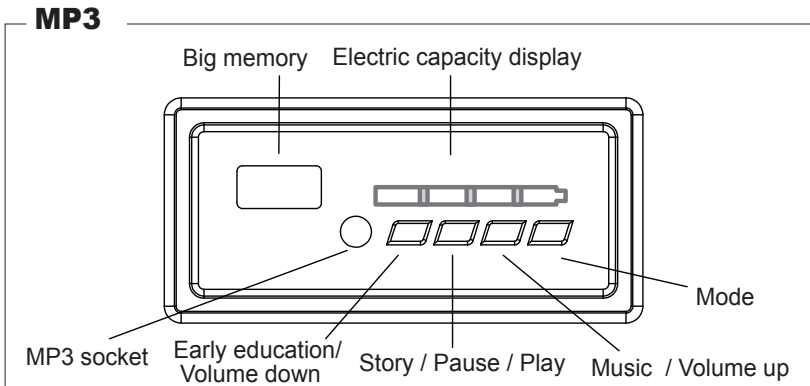
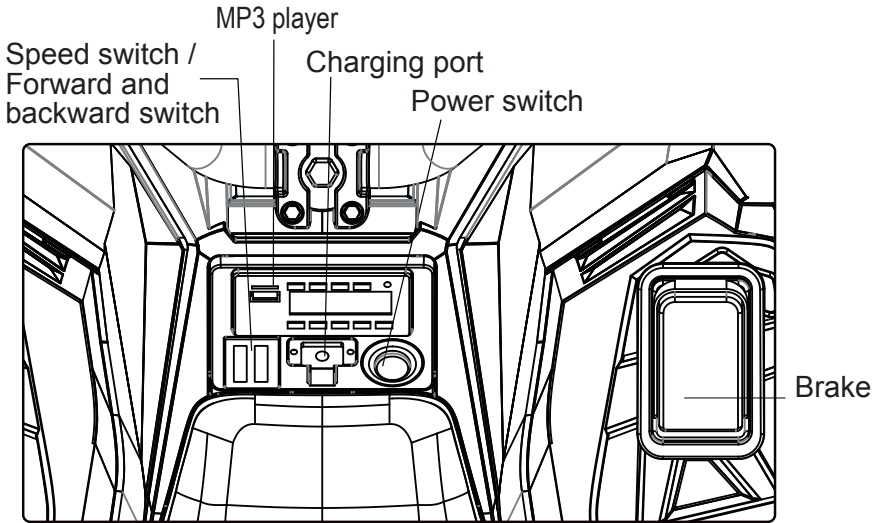

## CHARGING WAY

- For safety purpose, the charging must be done by adults. The first time you use it, please remove the engine cover, connect two red plugs, use it only after charging 8-12 hours. The car has two charging ways. Charge from dashboard or removable battery box. One charging port is located on dashboard, another charging port is located on removable battery box. Please follow the instructions to charge the battery.
- If the car has slowed down, it needs to be charged by 8-12 hours, maximum 20 hours.

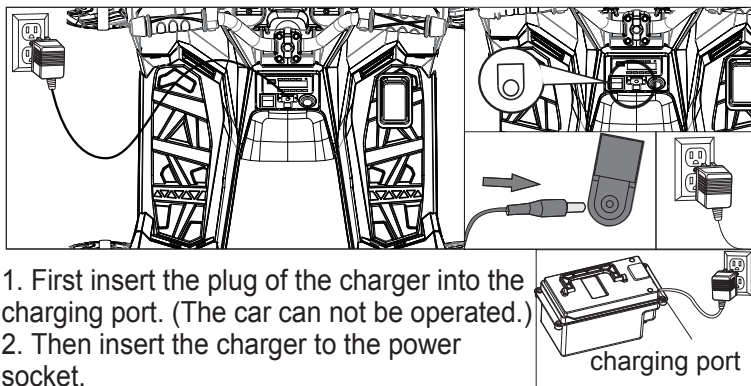

1. First insert the plug of the charger into the charging port. (The car can not be operated.)
2. Then insert the charger to the power socket.



### **WARNING:**

1. The toy is to be assembled by an adult. In unassembled state, it contains potentially hazardous sharp points & small parts, so please keep out of baby's reach.
2. CHOKING HAZARD – Small parts.
3. Not for children under 3 yrs.
4. Always wear shoes.
5. RISK OF FIRE. Do not bypass. Replace only with circuit protection device.
6. Protective equipment should be worn. Not to be used in traffic.

## **Attention:**

- Can only use the charger and battery according to manufacturers regulations.
- Do not mix old and new or different types of batteries.
- The battery terminal should not be short circuit.
- Do not open the battery or charger.
- Do not reverse the battery.
- Before charging, please check whether the charger, battery and plug are ok, if you find any broken parts, you must stop using it immediately. And do not use it until it is fully repaired.
- The battery will be little warm when being charged, it is normal. If not, it may be caused from the short circuit of charger or circuit board.
- Must use the pressing plate to fix the battery.
- Run out of battery must be handled by adults, remove the battery which has run out from toys to recycle properly and shall not be arbitrarily discard.
- If the product is going to be stored unused long time, it must be fully charged, and charge it every 3 months, so as to make sure the battery life.
- Charger and battery are not toys. Keep them away from children.

## **MAINTENANCE AND SERVICE**

1. Before use, parents should check whether all parts like batteries, charger, wires, plug, outer body and other parts are in good condition, check whether the screws are loose and whether there are potential safety hazards. Any damaged parts founded should be repaired before using.
2. After using the product for a period of time, use a small amount of lubricating oil to the moving parts to prevent wear and tear of rust.
3. Keep the car away from fire and direct sunlight. Place it stably, not upside down. The car shall be stored indoors or outdoors under cover.
4. The car should be kept away from hot items, such as stoves or heaters, or the plastic parts will melt. When charging, the car should be kept away from inflammable materials to prevent it from catching fire.
5. Charge in time after use. Charging should be done by adults. If the product is going to be unused for a long time, it must be fully charged. Charge it every month to extend the battery lifespan.

 **WARNING:**  
This toy contains batteries that are non-replaceable.  
A recommendation for adult supervision of young children.

 **WARNING:**  
To reduce risk of injury, adult supervision is required.  
Never use in roadways, near motor vehicles, on or near steep  
inclines of steps, swimming pools or other bodies of water, always  
wear shoes, and never allow more than 1 rider.  
Only use the specified by the manufacturer battery.  
Only use the charger specified by the manufacturer.