

VOLTZ TOYS™®

A subdivision of The DAAN Groups

CONTACT US

Before returning your product, please contact us first! Voltz Toys Customer Service can assist you with any replacement parts, damages, or defective issues reported. You can contact us directly at www.voltztoys.ca.

Email: help@voltztoys.ca

Phone number: 1-888-338-6589

Head Office: Unit 7-3600A Laird Rd, Mississauga, ON, L5L 6A6

USER MANUAL



MODEL: DG-82269



COMPLIANCE STANDARDS:

SOR/2011-17

SOR/2018-138

SOR/2016-195

SOR/2016-302

SOR/2018-83

SOR/2016-188

SOR/2014-254

EN71

ASTM F963-17

CPSIA

BOX CAR

ENGLISH

Please read the manual before using the product. The manual and carton contain important information. Please keep the manual for later references. Failure to follow the instructions in the manual may result in damages, accidents, or defective issues with the product.

To improve the product and quality, we may alter the structure, appearance, packing method, assembly method, and product function without any notice.

When there are any differences between the manual and the product, please refer to the actual product itself. We apologize for any inconvenience caused.

An adult should assemble the product. All pictures shown are for illustration and reference purposes only. The actual product may vary due to product enhancement.

Disclaimer:





The pictures in the instructions are for assembly reference only. Please refer to the actual product.



WARNING

This product is not used for transportation and only should be used under adult guidance and supervision. Parents should ensure that children have followed the safety measures before use. Children should use the toy with caution and under adult supervision. To prevent injury to users and others, basic coordination skills and awareness are required to avoid accidents, falls, or collisions.

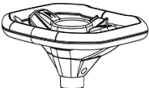
PARTS LIST

PARTS NAME	PICTURE	QTY	PARTS NAME	PICTURE	QTY
Car body	 #1	1	Handle bar	 #2	1
Footrest wheel	 #3	1	Hardware package	 #4	1
Charger	 #5	1	Manual	 #6	1

Disclaimer: The pictures in this instruction are for assembly reference only. Please refer to the actual product.

WARNING

This product is not the vehicle for transportation, it should be used under adult guidance. Parents should ensure that children have taken the safety measures before use. The toy should be used with caution since skill is required to avoid falls or collisions causing injury to the user or third party. Drive at low speed first, after mastering driving skills, try driving at the fast speed.

PRODUCT SPECIFICATIONS

Car Model	DG-82269
Battery	12V7AH*2
Suitable age	8- 12 years old
Weight Limit	50 kg
Product Size	44.5 x 42 x 66 cm
Speed	3-8 km / hour
Charging time	8-12 hours
Charger	AC 110-220V (input) DC 24V-1000mA (output)
Fuse	Auto-reset fuse

ASSEMBLY PREPARATION

- Adults must assemble the car.
- The product contains small items that may present choking hazards. Keep children away from assembling. Children under 36 months are prohibited from using.
- Review and count all parts carefully before assembling. Properly dispose of all plastic bags and other packaging materials.

Attention: Please install the car as per the following order procedure. Otherwise, some parts can not be installed correctly.

FUNCTION DESCRIPTION

Remove the seat cover, here is a small storage box.

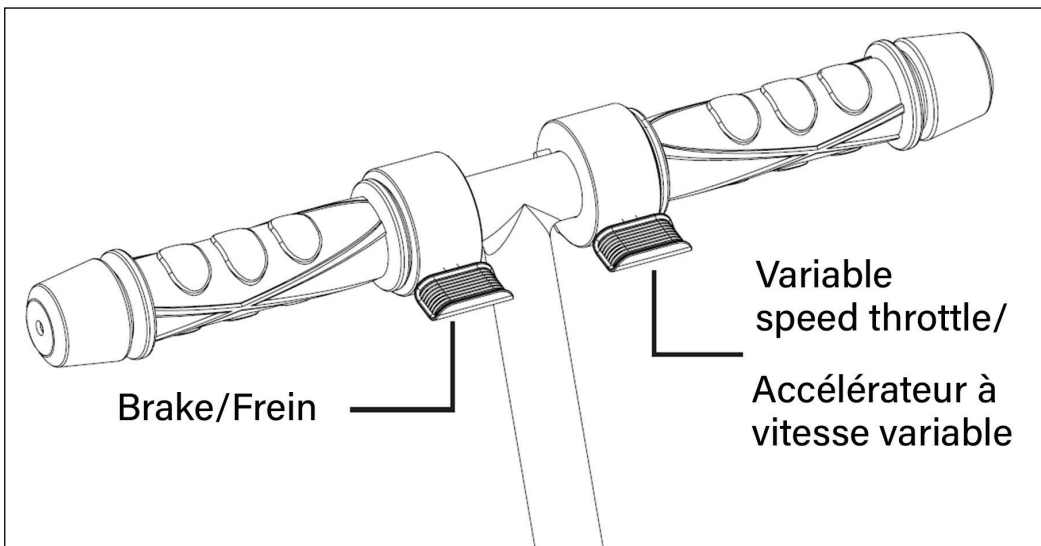
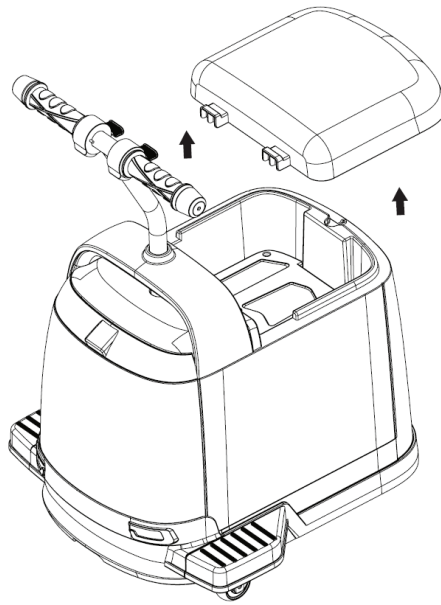

There is a variable speed switch on the handle bar, speed controlled by this switch, the harder you press down, the faster the car will be, release the switch, the car will come to a stop.

1. FOOTREST ASSEMBLY

Parts required: #1, #3

Slide both sides of foot rest into the car body. Press firmly, then secure the connection with 6x screws each side as shown on the diagram.

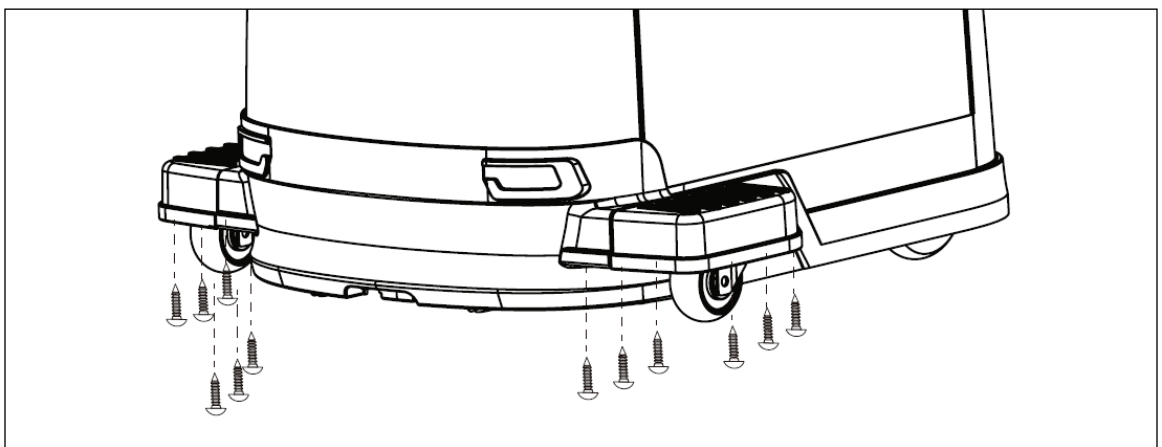
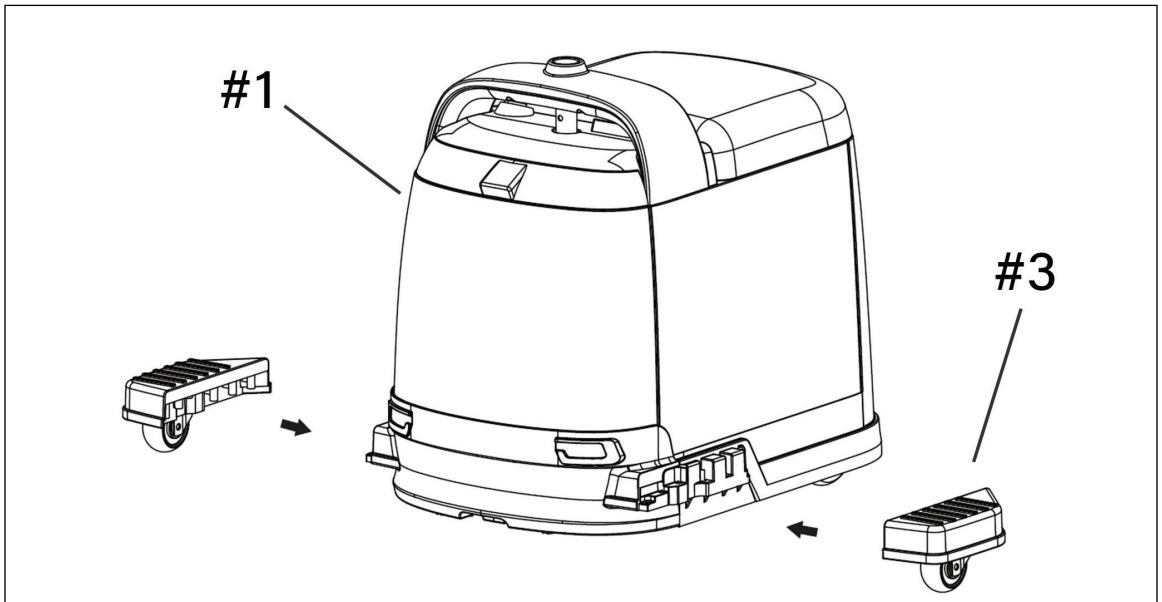

2. HANDLE BAR ASSEMBLY

Parts required: #2

Insert the handle into the designated slot on the car body, fix the connection with bolt/nut set.

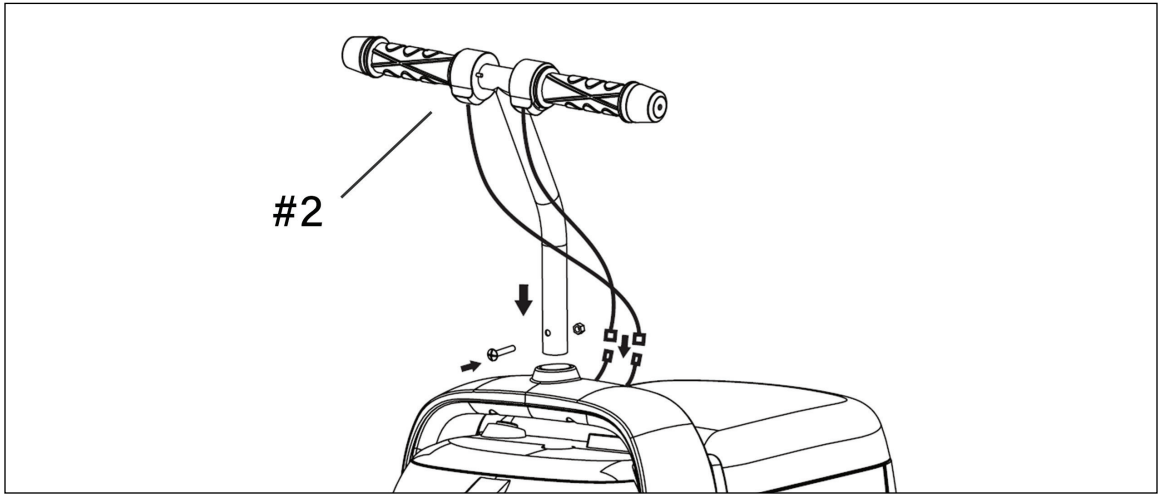

Connect the matching colour cables. Slide as much cable as possible through the opening, then place the cover and secure it with 2 x screws.

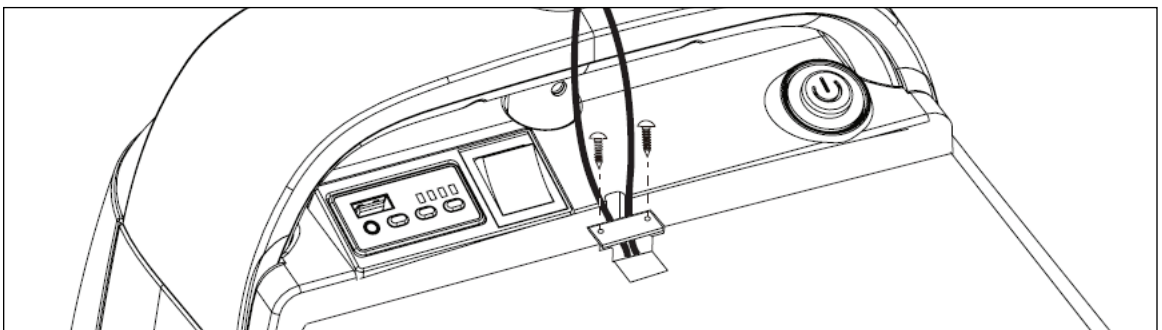
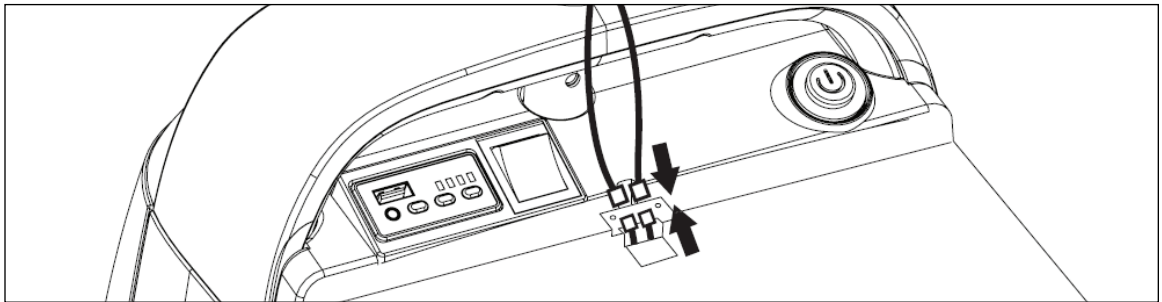

FUNCTION INTRODUCTION

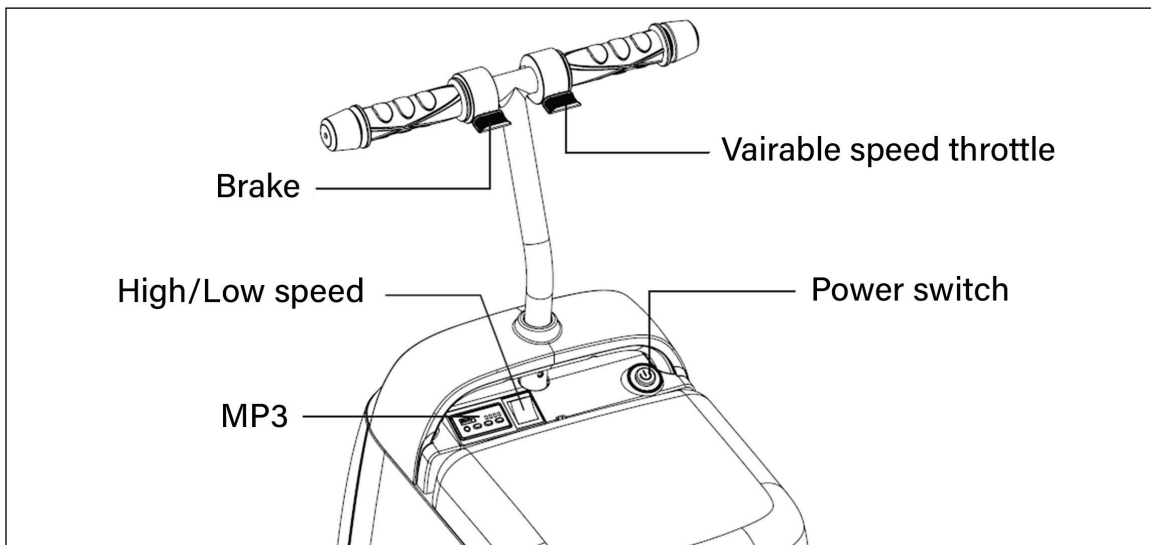

MP3

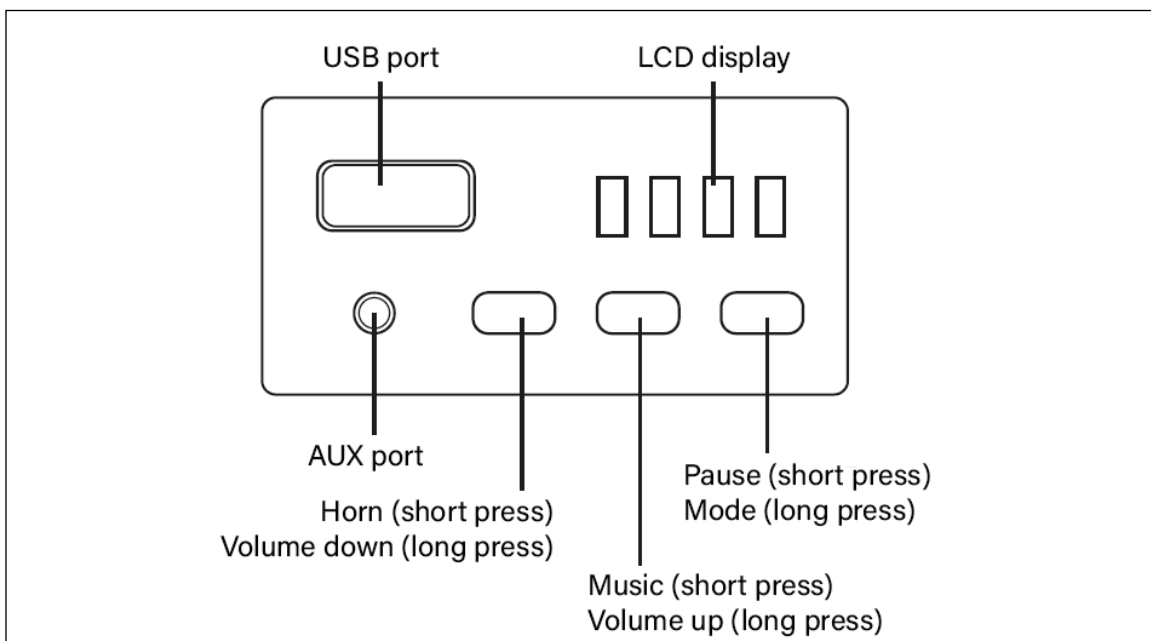

FUSE

This car is equipped with an auto-reset fuse. If the car stops suddenly while driving, it is caused by the instantaneous current exceeding, enabling the fuse to trip. This will result in the car disabling for about 8 seconds, and this fuse can be reset.

To avoid tripping the fuse:

- Do not exceed the maximum load capacity; the maximum load is 50kg.
- Do not drag any objects behind the product.
- Do not expose water or other liquids to the battery and other electrical components.
- Do not change and/or modify the circuit system and the structure of the product.

SECURITY WARNING

1. The assembly and charging routine of the vehicle must be under adult supervision at all times.
2. This product is recommended for children ages 8-12 years old. Do not exceed the maximum weight limit of 50kg.
3. This product is ideal for driving on hard flat surfaces (e.g, concrete, gravel, asphalt, etc).
4. It is strictly prohibited to drive on the street, roads, potholes, and slopes.
5. Avoid driving in sand, grass, uneven ground, or other terrains that may damage the vehicle.
6. Children should be given full instructions and how to operate the car. Improper use can cause damages or accidents.
7. Parents are responsible to supervise at all times to avoid accidents while children are driving.
8. Avoid driving in the rain or flooded pathways. Exposure to water can damage the motor, circuit, and other electrical equipment.
9. Parents should inspect the battery charger to ensure it is in good working condition. Any damages or abnormalities regarding wires, plugs, or other components are prohibited to continue using. Do not use it until parts are completely repaired.

10. To maintain product life and safety, avoid damaging the charger, battery, or electrical circuit. The car must use the default configuration of the dedicated charger and power supply.
11. Rechargeable batteries should be removed from the toy before charging.
12. When inactive, disconnect the car's power by unplugging the (red) battery wire, ensuring all switches are in the "STOP" or "OFF" position.
13. The charger is not a toy. Please keep away from children.
14. Using non-manufacturer or third-party parts is strictly prohibited.
15. This product is mainly composed of PP material. The expected product-usage life is two years.

USAGE DIRECTION

Before using the car, review the following procedures to ensure functionality:

1. All steps are followed per the instructions to complete the car's assembly. Specifically, the battery wire is connected correctly, and the power supply has been switched on to confirm functionality.
2. Make sure all parts requiring hardware are fixed tightly and correctly.
3. Adults must ensure children have taken safety measures before use.
4. To reduce accidents while using, the child must be seated at all times.
5. Follow the product's recommended seating capacity. Please do not exceed the maximum number of users to ride.
6. Adults must always supervise their children while the car is in use.
7. Adults are responsible for the care and guidance of their child while the car is in use, ensuring the child is not left unattended.
8. Pay attention to the driving environment and surfaces. Ensure the car is not driven in an unsafe environment.
9. Pay attention to the road, trenches, riverside, slopes, or uneven ground.
10. Not to be used on public roads or near ongoing traffic.
11. The car should only be used in daytime and under light for visibility. Do not use the car at night or under low visibility.
12. To avoid unexpected obstacles or events, adults must supervise at all times.

CHARGING PROCEDURES

- For safety purposes, charging must be done by adults.
- The charging port is located under the seat. Follow the instructions to charge the battery.

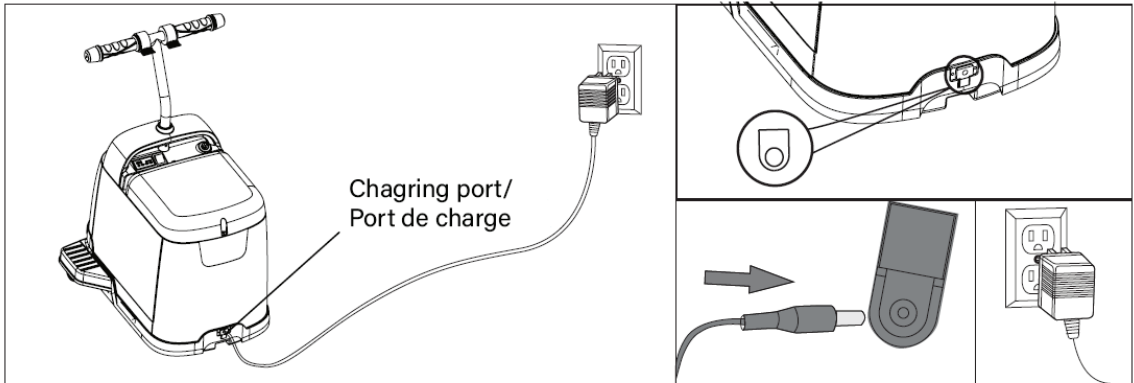

1. First, insert the charger into the charging port.
2. Carefully insert the charger outlet into the power outlet. Please note the car will not turn on when the car is connected.

⚠ WARNING

1. The assembly of the car must be done by an adult. When unassembled, it contains potentially hazardous parts that are sharp or small. Please keep out of children's reach.
2. Choking hazards of small parts.
3. Not for children under 36 months. Recommended for 8-12 years old.
4. Always wear shoes or footwear when using the toy.
5. RISK OF FIRE. Do not bypass. Replace only with circuit protection devices.
6. Protective equipment should be worn.

ATTENTION

- Dedicated charger and battery can only be used under manufacturer's regulations.
- Do not mix old, new or different types of batteries.
- The battery terminal should not be short circuit.
- Do not open the battery or charger.
- Do not reverse the battery.
- Before charging, please inspect the charger, battery, and plug to ensure no damages or abnormalities are found. If any damages are found, discontinue usage of the car until the parts are replaced or resolved.
- The battery may feel warm while being charged - this is normal. If the temperature from the charger does not elevate, it may be caused by a short circuit from the charger or circuit board.
- Must use the pressing plate to fix the battery.
- When the battery is no longer functional, adults are responsible for removing and safely disposing of the battery in a battery-safe disposition facility.
- When the product is inactive (at least one month), it must be fully charged. Unplug the (red) battery wire, and charge it at least once a month to ensure battery functionality and life.
- The charger and battery are not toys. Keep away from children.

MAINTENANCE AND SERVICE

1. Before using, adults are responsible for reviewing the product and essential parts are in a functional condition. Check whether screws are loose or other potential hazards. Any damaged or defective parts must be repaired or resolved before using.
2. Use a small amount of oil-based lubricant to moving parts to prevent rust or wear or tear (e.g. motors, gears, hardware, etc.).
3. Keep the car away from fire and direct sunlight. Store the car in a stable position and must be kept safely away from extreme temperatures or climate.

4. The car must be kept away from hot objects, such as stoves and heaters. Direct exposure to hot objects will melt the plastic. The car must be kept away from flammable materials to prevent ignition or fire when charging.
5. After using the car, charge the car adequately and must be done by an adult. If the product is inactive, it must be fully charged. Charge at least once a month to ensure battery functionality and life.
6. Use a soft cloth to clean the car. Do not use chemical solvents, soap, or water to clean the vehicle. Do not drive under precipitation (e.g. snow, rain, etc.) as this will damage the motor, battery and circuit system.
7. When inactive or discontinued, shut off all power by disconnecting the (red) battery wire, and all switches are in the "STOP" or "OFF" position.
8. Do not use third-party or different fuses.
9. Do not modify the product structure or circuit system. Maintenance and repair work must be done under the guidance of a professional or technician.
10. Do not use the product for other purposes.
11. Battery negative short circuit is prohibited.
12. Rechargeable batteries must be charged under adults' supervision. Non-rechargeable batteries can not be charged. Ensure the batteries are installed in the correct polarity.
13. Do not mix old and new batteries, including different types of batteries.
14. Low batteries should be removed from the car and kept away from children.
15. Disconnect the batteries when completely inactive or discontinued. Do not let children use the car in this state.

TROUBLESHOOTING

The car does not move or power on	<ul style="list-style-type: none"><input type="checkbox"/> The power switch is in the “OFF” position.<input type="checkbox"/> The fuse is not functioning properly.<input type="checkbox"/> The battery (red) wire is not connected properly, check the battery terminals, and the battery wire.<input type="checkbox"/> If the charger is plugged in, the car will not turn on. Unplug the charger first before turning on the car.<input type="checkbox"/> Check the pedal switch if it is disconnected or defective. <p>The wheels are stuck and cannot move; check the wheels and motors if functioning properly.</p>
The car is moving slowly	<ul style="list-style-type: none"><input type="checkbox"/> If the battery is not fully charged, it will not run properly. Charge the car adequately for 8-12 hours.<input type="checkbox"/> Check the wheels and motors. Inspect the gears on the wheels, and motors if they are functioning properly. If damaged, the car will not run accordingly.<input type="checkbox"/> The car has a maximum weight capacity. If the user weight exceeds the recommended weight, the car will not run at full speed.
The battery does hold a charge	<ul style="list-style-type: none"><input type="checkbox"/> If the charger is defective. The charger must be showing a red or green light depending on the status of the battery. If the light is not showing, changing from red to green, or staying one color, the charger may be defective.<input type="checkbox"/> The battery life has deteriorated. Please use a voltmeter to verify the voltage post-charge. If it falls below the standard voltage amount, please replace the battery.<input type="checkbox"/> If the charging port between the charger and battery is defective. The charging port provides electricity output between the charger and battery. If the charging port is defective, then the battery can not charge.