

# VOLTZ TOYS™®

A subdivision of The DAAN Groups

## CONTACT US

Before returning your product, please contact us first! Voltz Toys Customer Service can assist you with any replacement parts, damages, or defective issues reported. You can contact us directly at [www.voltztoys.ca](http://www.voltztoys.ca).

Email: [help@voltztoys.ca](mailto:help@voltztoys.ca)

Phone number: 1-888-338-6589

Head Office: Unit 7-3600A Laird Rd, Mississauga, ON, L5L 6A6

## USER MANUAL



**MODEL: DG-80718**



## COMPLIANCE STANDARDS:

SOR/2011-17

SOR/2018-138

SOR/2016-195

SOR/2016-302

SOR/2018-83

SOR/2016-188

SOR/2014-254

EN71

ASTM F963-17

CPSIA

**ELECTRIC RIDE-ON**

**ENGLISH**

Please read the manual before using the product. The manual and carton contain important information. Please keep the manual for later references. Failure to follow the instructions in the manual may result in damages, accidents, or defective issues with the product.

To improve the product and quality, we may alter the structure, appearance, packing method, assembly method, and product function without any notice.

When there are any differences between the manual and the product, please refer to the actual product itself. We apologize for any inconvenience caused.

An adult should assemble the product. All pictures shown are for illustration and reference purposes only. The actual product may vary due to product enhancement.

**Disclaimer:**



The pictures in the instructions are for assembly reference only. Please refer to the actual product.



**WARNING**

This product is not used for transportation and only should be used under adult guidance and supervision. Parents should ensure that children have followed the safety measures before use. Children should use the toy with caution and under adult supervision. To prevent injury to users and others, basic coordination skills and awareness are required to avoid accidents, falls, or collisions.

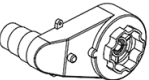
# PARTS LIST

PARTS NAME	PICTURE	QTY	PARTS NAME	PICTURE	QTY
Car body	 #1	1	Windshield	 #2	1
Seat	 #3	1	Steering wheel	 #4	1
Rear mirror	 #5	1	Wheel	 #6	2
Driving wheel	 #7	2	Trolley wheel	 #8	2
M10 washer	 #9	6	M8 nut	 #10	4
Wheel shaft cover	 #11	4	M5 x 35 bolt + M5 nut	 #12	1
Motor	 #13	2	M4 x 12 screw	 #14	2
Charger	 #15	1	Remote control	 #16	1
User manual	 #17	1	Spanner	 #18	2

# PRODUCT SPECIFICATIONS

Car Model	DG-80718
Battery	12V4.5AH*1
Suitable age	37-95 months
Weight Limit	30 kg
Product Size	112.8 x 67.1 x 52.4cm
Speed	3-5 km / hour
Charging time	8-12 hours
Charger	AC 100V-240V 50/60Hz (input) DC 12V/15V (output)
Fuse	Auto-reset fuse

## ASSEMBLY PREPARATION

- Adults must assemble the car.
- The product contains small items that may present choking hazards. Keep children away from assembling. Children under 36 months are prohibited from using.
- Review and count all parts carefully before assembling. Properly dispose of all plastic bags and other packaging materials.

**Attention:** Please install the car as per the following order procedure. Otherwise, some parts can not be installed correctly.

# PARTS NAME

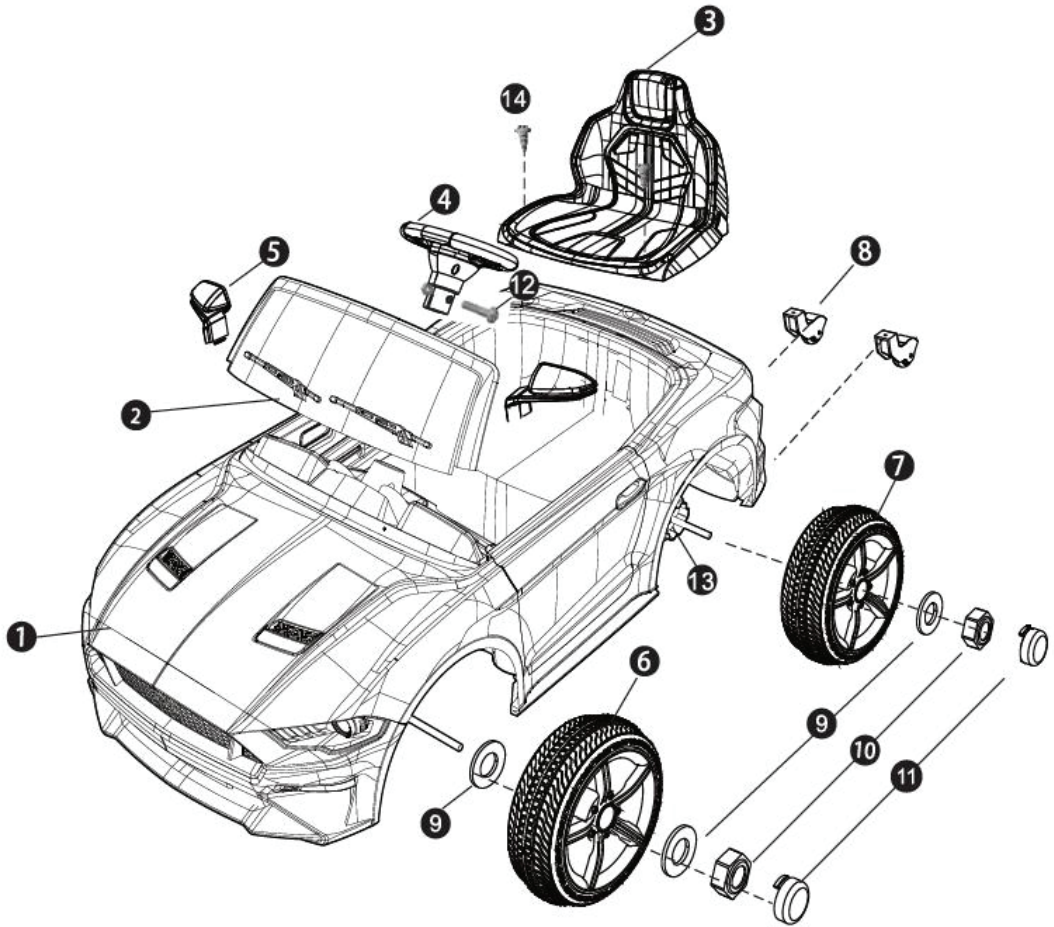

# TROLLEY FUNCTION

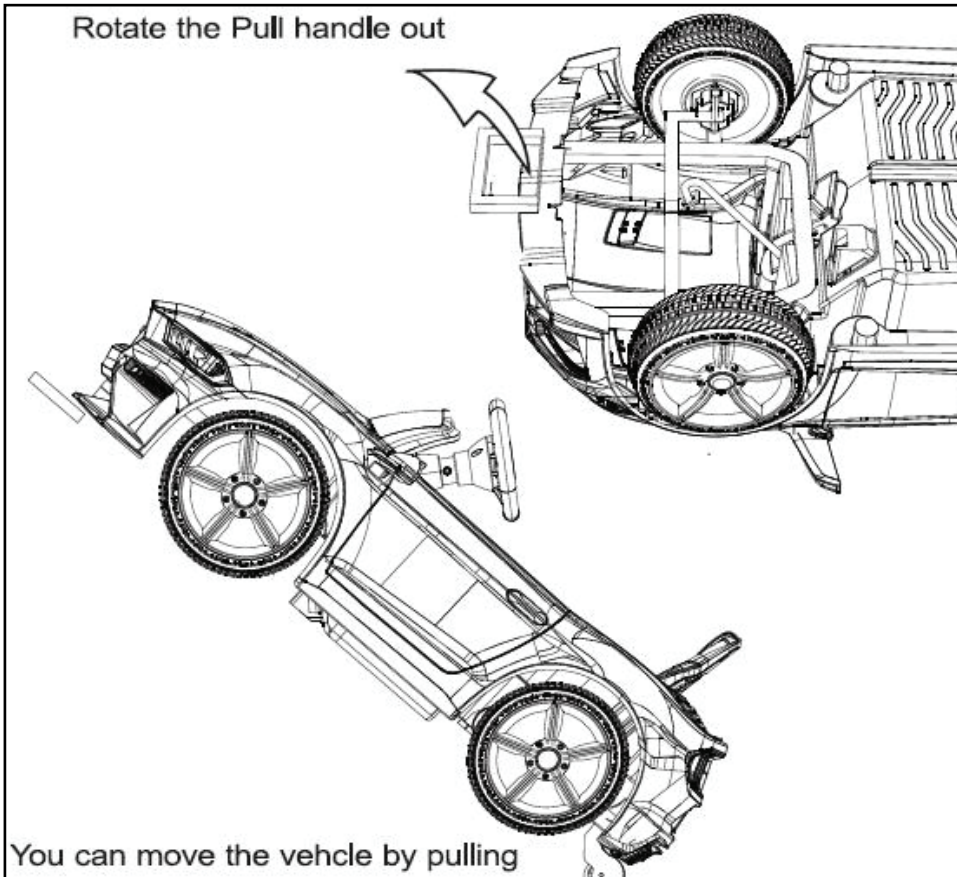

# 1. FRONT WHEEL ASSEMBLY

**Parts required: #6, #9, #10, #11, #18**

Begin the assembly with the car in an upside-down position. The front wheel is to be assembled in the following order. Insert the washer (#9), front wheel (#6), washer (#9), and M8 nut (#10). Tighten the nut to secure (using #18), and install the wheel cover (#11). Repeat these steps on the other side.

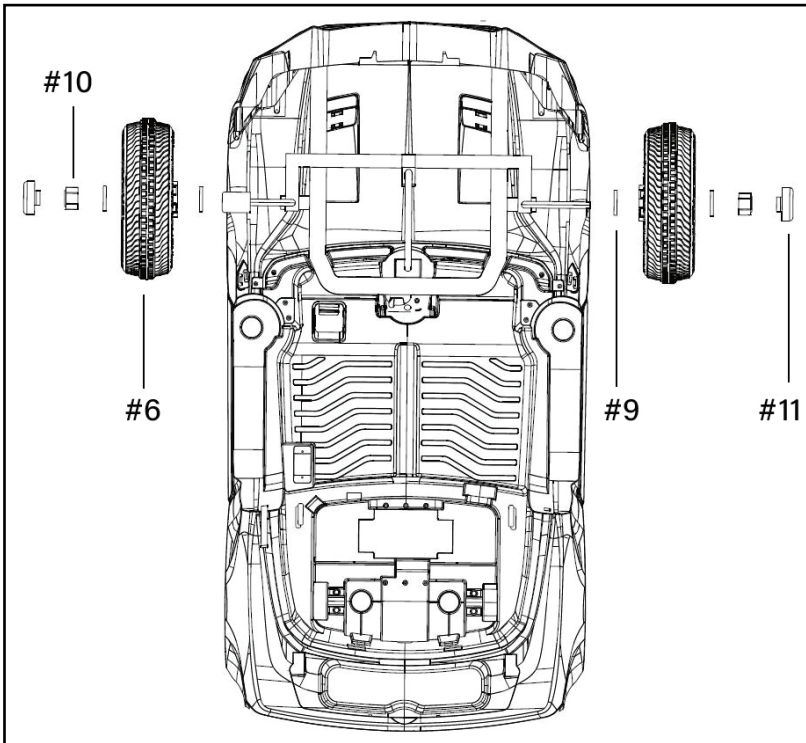

# 2. REAR WHEEL ASSEMBLY

**Parts required: #7, #9, #10, #11, #13, #18**

Ensure the drive motor is pre-installed on the rear axle. The rear wheel is to be assembled in the following order. Insert the washer (#9), rear wheel (#7), washer (#9), and M8 nut (#10). Tighten the nut to secure (using #18), and install the wheel cover (#11). Repeat these steps on the other side.

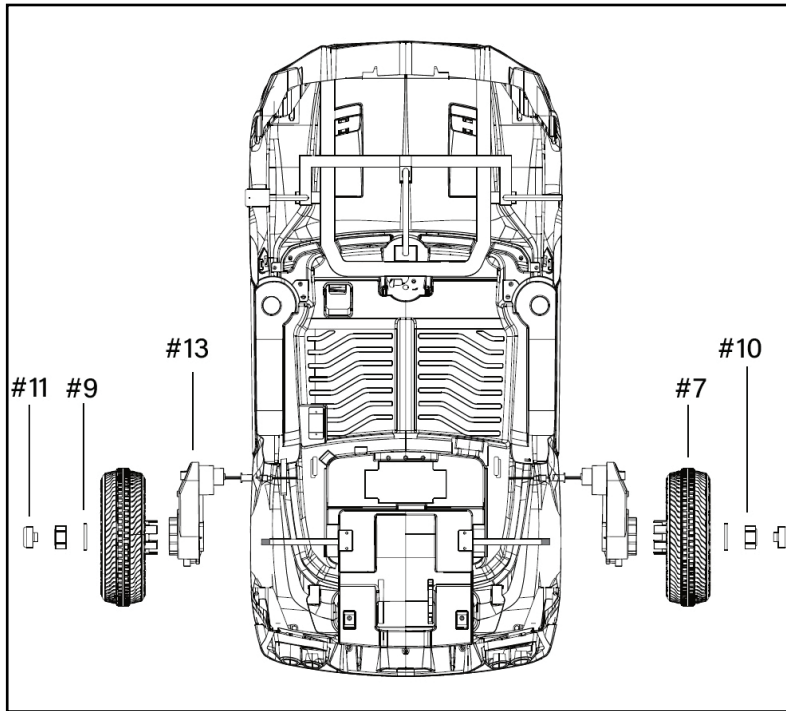

### 3. TROLLEY WHEEL ASSEMBLY

**Parts required: #8**

The trolley wheels are to be installed underneath the car at the rear end. Attach the trolley wheels (#8) to slots on the car body. Fix the wheels with two M4x12 screws (#14).

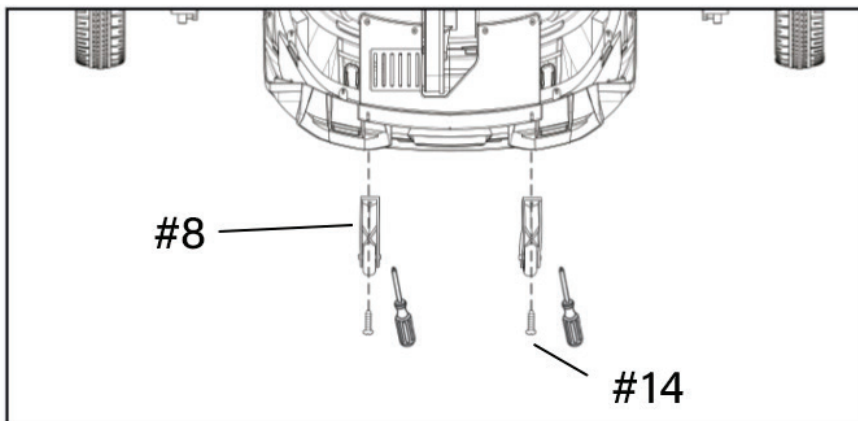



## 4. POWER CONNECTION

**Parts required: #N/A**

Flip the car in an upright position. Locate the battery compartment. Connect the (red) battery wire together to enable power. (Attention: The motor cables can not be connected in reverse. Once all wires are connected, please check if the car drives correctly).

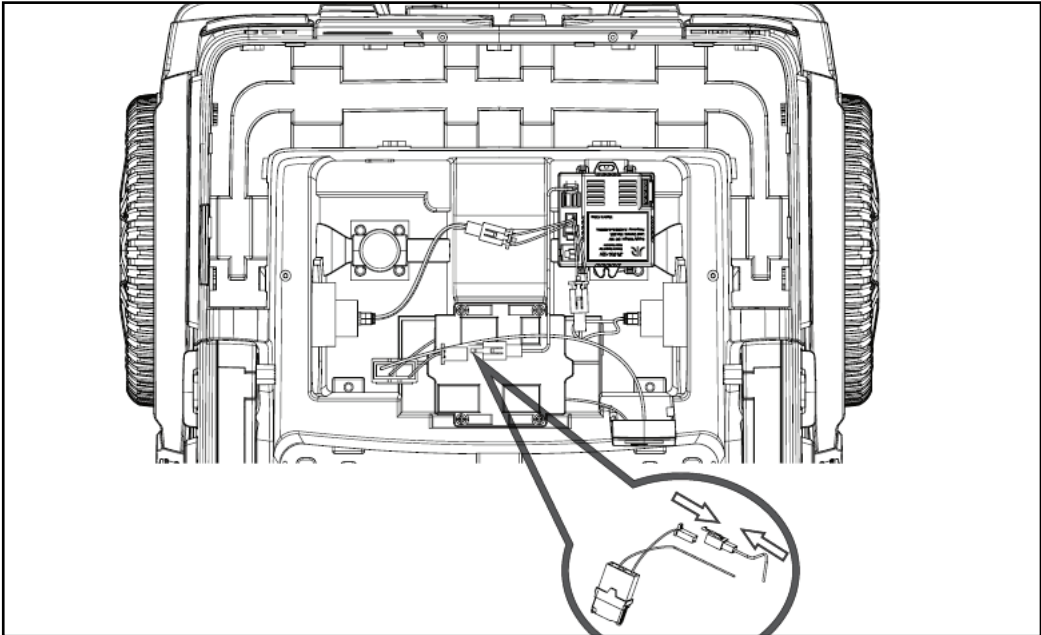

## 5. SEAT ASSEMBLY

**Parts required: #3, #14**

Flip the car in an upright position. Place the seat (#3) on top of the battery compartment, and ensure the screw holes are aligned onto the car body. Fix the seat with two M4x12 screws.

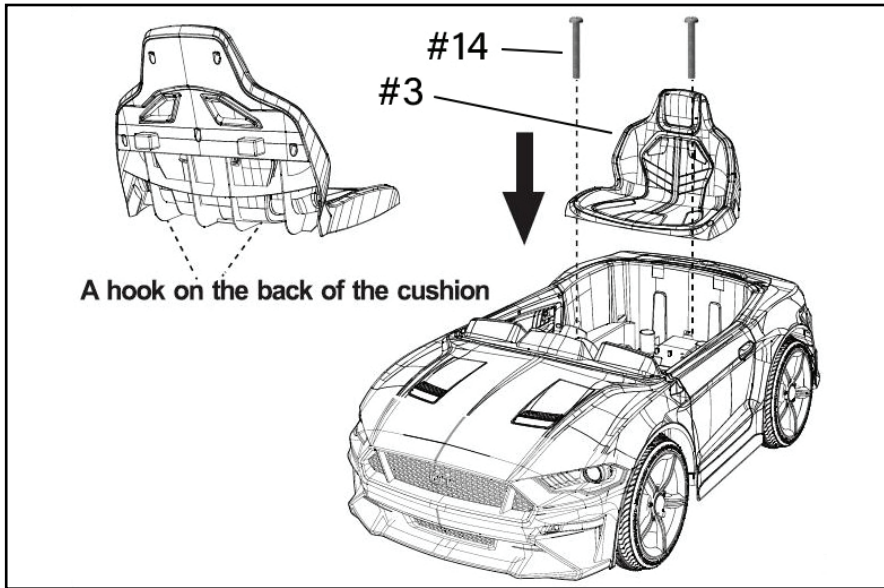

## 6. STEERING WHEEL ASSEMBLY

Parts required: #4

Connect the steering wheel with its corresponding wire connector from the steering column. Insert the steering wheel (#4) to the steering column, and ensure the screw holes are aligned.

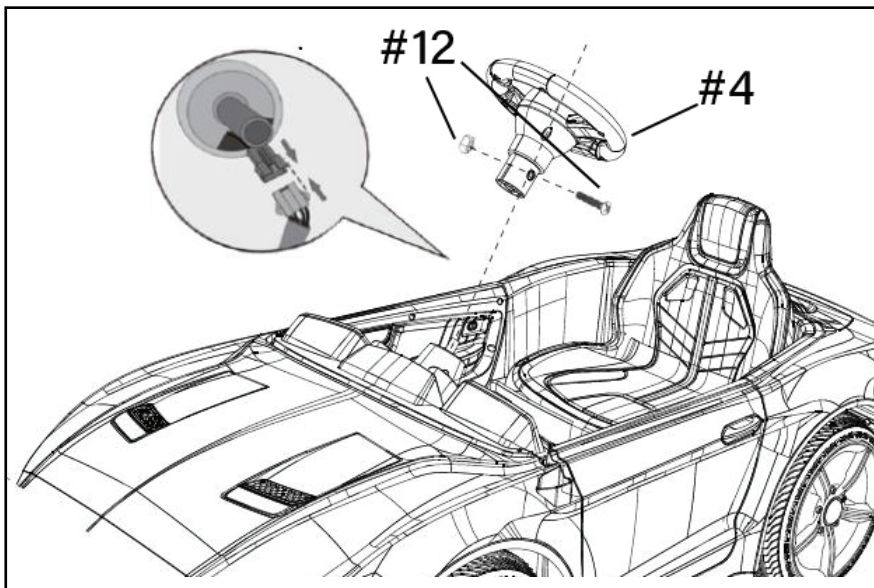

## 7. WINDSHIELD ASSEMBLY

**Parts required: #2, #14**

Install the windshield (#2) on the corresponding slots from the car body. Press down firmly until it “snaps” into place. (Attention: The clips on the windshield need to be fully clamped into the slots on the car)

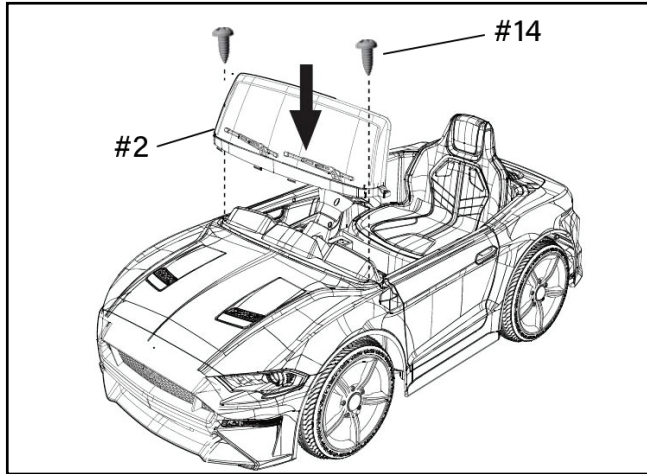

## 8. SIDE MIRROR ASSEMBLY

**Parts required: #5**

Install the side mirrors (#5) on the corresponding slots from the car body. Press firmly until it “snaps” into place.

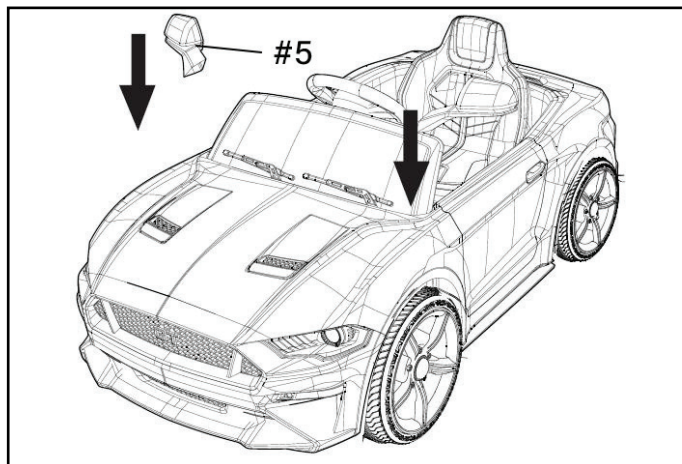

# FUSE

This car is equipped with an auto-reset fuse. If the car stops suddenly while driving, it is caused by the instantaneous current exceeding, enabling the fuse to trip. This will result in the car disabling for about 8 seconds, and this fuse can be reset.

To avoid tripping the fuse:

- Do not exceed the maximum load capacity; the maximum load is 60kg.
- Do not drag any objects behind the product.
- Do not expose water or other liquids to the battery and other electrical components.
- Do not change and/or modify the circuit system and the structure of the product.

# SECURITY WARNING

1. The assembly and charging routine of the vehicle must be under adult supervision at all times.
2. This product is recommended for children ages 37-95 months. Do not exceed the maximum weight limit of 60kg.
3. This product is ideal for driving on hard flat surfaces (e.g, concrete, gravel, asphalt, etc).
4. It is strictly prohibited to drive on the street, roads, potholes, and slopes.
5. Avoid driving in sand, grass, uneven ground, or other terrains that may damage the vehicle.
6. Children should be given full instructions and how to operate the car. Improper use can cause damages or accidents.
7. Parents are responsible to supervise at all times to avoid accidents while children are driving.
8. Avoid driving in the rain or flooded pathways. Exposure to water can damage the motor, circuit, and other electrical equipment.
9. Parents should inspect the battery charger to ensure it is in good working condition. Any damages or abnormalities regarding wires, plugs, or other components are prohibited to continue using. Do not use it until parts are completely repaired.

10. To maintain product life and safety, avoid damaging the charger, battery, or electrical circuit. The car must use the default configuration of the dedicated charger and power supply.
11. Rechargeable batteries should be removed from the toy before charging.
12. When inactive, disconnect the car's power by unplugging the (red) battery wire, ensuring all switches are in the "STOP" or "OFF" position.
13. The charger is not a toy. Please keep away from children.
14. Using non-manufacturer or third-party parts is strictly prohibited.
15. This product is mainly composed of PP material. The expected product-usage life is two years.

## **USAGE DIRECTION**

Before using the car, review the following procedures to ensure functionality:

1. All steps are followed per the instructions to complete the car's assembly. Specifically, the battery wire is connected correctly, and the power supply has been switched on to confirm functionality.
2. Make sure all parts requiring hardware are fixed tightly and correctly.
3. Adults must ensure children have taken safety measures before use.
4. To reduce accidents while using, the child must be seated at all times.
5. Follow the product's recommended seating capacity. Please do not exceed the maximum number of users to ride.
6. Adults must always supervise their children while the car is in use.
7. Adults are responsible for the care and guidance of their child while the car is in use, ensuring the child is not left unattended.
8. Pay attention to the driving environment and surfaces. Ensure the car is not driven in an unsafe environment.
9. Pay attention to the road, trenches, riverside, slopes, or uneven ground.
10. Not to be used on public roads or near ongoing traffic.
11. The car should only be used in daytime and under light for visibility. Do not use the car at night or under low visibility.
12. To avoid unexpected obstacles or events, adults must supervise at all times.

# Dashboard (function reference diagram)

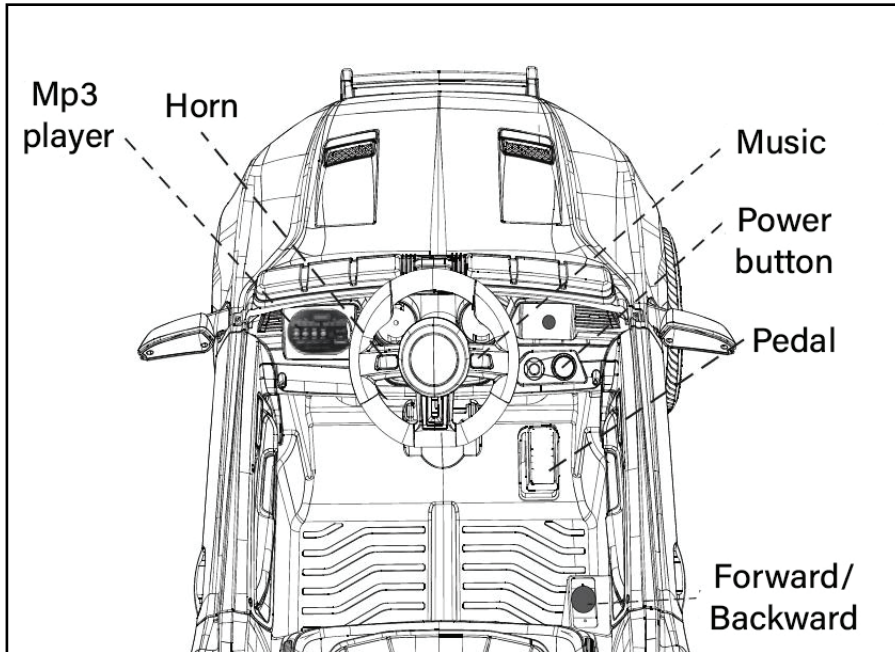

- A. Power Switch ---(1 )Turn on power switch ,the light will be bright and there is engine sound.
- B. Dashboard equipped with music function and it can connected cell-phone, adjust the volume ,power display ,etc.
- C. Steering wheel ---The steering wheel equipped with music and horn, Children can adjust by themselves.
- D. Go forward/ Stop/ Back forward switch-When manual for driving can control to go forward or backward when they step on the foot pedal.

# REMOTE CONTROL INSTRUCTION

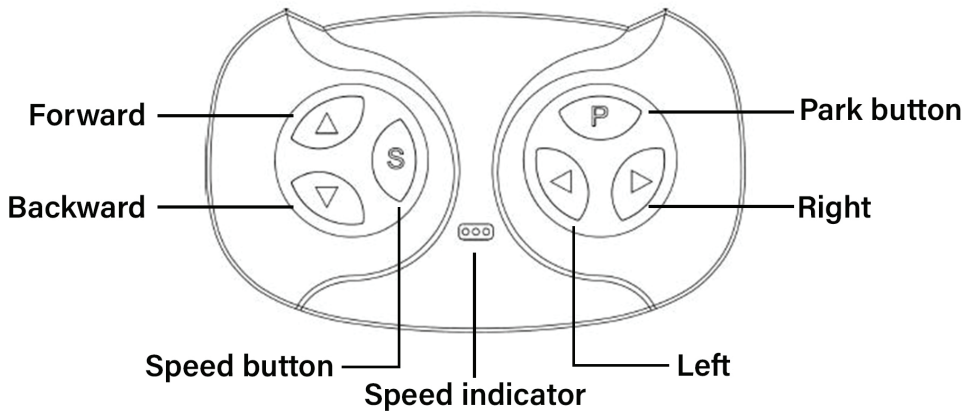

## 2.4GHz Remote Control Pairing Procedures

1. To pair the remote with the vehicle, install two AAA 1.5V batteries. Unscrew and push the battery cover open on the back of the remote. Please pay attention to the positive and negative polarity in the battery holder. After installing batteries, close the battery cover.
2. Hold the "Forward" and "Backward" key together (up and down key) for 3 seconds. The light on the center will start to flash - this indicates the pairing has initiated.
3. Turn on the power from the vehicle while the remote is flashing. After turning on the vehicle, the lights on the remote will stop and stay lit. This indicates the pairing has been successful and connected to your vehicle.

**Remote Instructions:** "S" Key: Speed button; adjust the speed from low, medium, or high. The light on the center of the remote will indicate the speed level. "P" Key: Park button; disable the vehicle's movement and stay parked. The car will not run with the pedal or remote. To enable power, press the "P" button again.

## **WARNING**

1. When operating the car with the remote, the distance between the car to remote should not exceed 10m range.
2. The remote is provided for adult's to operate. Keep away from children.
3. Before using the remote, carefully read the instruction manual, ensuring all functions are reviewed properly before operating.
4. Please switch to the "P" gear before entering the car.
5. The car should not be driven on dangerous terrain or environments. This includes the road, bodies of water, or obstacles.
6. Do not expose the remote to water or rain. Water exposure may result in circuit damage.
7. Do not mix old and new batteries, including different brands of batteries.
8. When the remote is inactive for an extended period, it is recommended to remove the batteries to avoid battery leakage and corrosion to the circuit board.
9. Do not drop or throw the remote control.
10. Install batteries with correct polarity to avoid short circuits.
11. Charging is to be done by adults. Non-rechargeable batteries can not be charged.
12. Low batteries should be removed and kept away from children. Batteries are not a toy.
13. Remove the battery if the car is inactive (at least one month) for an extended period. Properly remove and handle batteries, and keep away from children.
14. If the remote can only operate the car in less than 3 meters, this indicates the battery is low in the remote. Change the two AAA batteries accordingly.



**Changing the remote batteries:** Unscrew the battery cover using a screwdriver. Following the arrow, press in the following direction to open the cover. Replace the batteries according to their corresponding polarity.

**How to insert batteries:** Use a screwdriver to unscrew the back cover of the remote. Install two AAA 1.5V alkaline type batteries according to the diagram (batteries not included). Fix the battery cover with a screw.

**How to remove batteries:** Use a screwdriver to unscrew the back cover of the remote. Open the cover and remove the two AAA 1.5V alkaline type batteries. Close the battery cover, fix with a screw.

## **WARNING**

- Do not charge non-rechargeable batteries for the remote.
- Batteries for the remote must be inserted with the correct polarity.
- When the remote is low in battery, please remove and swap the batteries.
- Rechargeable batteries for the remote must be charged under adult supervision.
- Rechargeable batteries must be removed from the remote before being charged.

## **CHARGING PROCEDURES**

- For safety purposes, charging must be done by adults.
- When initially assembled, connect the (red) battery wires under the hood. Charge for 8-12 hours before using.
- The charging port is located on the dashboard. Follow the instructions to charge the battery.
- If the car is starting to slow down, this indicates the battery is low. Recharge for 8-12 hours, maximum 20 hours. Do not overcharge or undercharge.



1. First, insert the charger into the charging port.
2. Carefully insert the charger outlet into the power outlet. Please note the car will not turn on when the car is connected.

## **WARNING**

1. The assembly of the car must be done by an adult. When unassembled, it contains potentially hazardous parts that are sharp or small. Please keep out of children's reach.
2. Choking hazards of small parts.
3. Not for children under 36 months. Recommended for 37-95 months.
4. Always wear shoes or footwear when using the toy.
5. RISK OF FIRE. Do not bypass. Replace only with circuit protection devices.
6. Protective equipment should be worn.

## **ATTENTION**

- Dedicated charger and battery can only be used under manufacturer's regulations.
- Do not mix old, new or different types of batteries.
- The battery terminal should not be short circuit.
- Do not open the battery or charger.
- Do not reverse the battery.

- Before charging, please inspect the charger, battery, and plug to ensure no damages or abnormalities are found. If any damages are found, discontinue usage of the car until the parts are replaced or resolved.
- The battery may feel warm while being charged - this is normal. If the temperature from the charger does not elevate, it may be caused by a short circuit from the charger or circuit board.
- Must use the pressing plate to fix the battery.
- When the battery is no longer functional, adults are responsible for removing and safely disposing of the battery in a battery-safe disposition facility.
- When the product is inactive (at least one month), it must be fully charged. Unplug the (red) battery wire, and charge it at least once a month to ensure battery functionality and life.
- The charger and battery are not toys. Keep away from children.

## **MAINTENANCE AND SERVICE**

1. Before using, adults are responsible for reviewing the product and essential parts are in a functional condition. Check whether screws are loose or other potential hazards. Any damaged or defective parts must be repaired or resolved before using.
2. Use a small amount of oil-based lubricant to moving parts to prevent rust or wear or tear (e.g. motors, gears, hardware, etc.).
3. Keep the car away from fire and direct sunlight. Store the car in a stable position and must be kept safely away from extreme temperatures or climate.
4. The car must be kept away from hot objects, such as stoves and heaters. Direct exposure to hot objects will melt the plastic. The car must be kept away from flammable materials to prevent ignition or fire when charging.
5. After using the car, charge the car adequately and must be done by an adult. If the product is inactive, it must be fully charged. Charge at least once a month to ensure battery functionality and life.

6. Use a soft cloth to clean the car. Do not use chemical solvents, soap, or water to clean the vehicle. Do not drive under precipitation (e.g. snow, rain, etc.) as this will damage the motor, battery and circuit system.
7. When inactive or discontinued, shut off all power by disconnecting the (red) battery wire, and all switches are in the "STOP" or "OFF" position.
8. Do not use third-party or different fuses.
9. Do not modify the product structure or circuit system. Maintenance and repair work must be done under the guidance of a professional or technician.
10. Do not use the product for other purposes.
11. Battery negative short circuit is prohibited.
12. Rechargeable batteries must be charged under adults' supervision.  
Non-rechargeable batteries can not be charged. Ensure the batteries are installed in the correct polarity.
13. Do not mix old and new batteries, including different types of batteries.
14. Low batteries should be removed from the car and kept away from children.
15. Disconnect the batteries when completely inactive or discontinued. Do not let children use the car in this state.

# TROUBLESHOOTING

The car does not move or power on	<ul style="list-style-type: none"><li><input type="checkbox"/> The power switch is in the “OFF” position.</li><li><input type="checkbox"/> The fuse is not functioning properly.</li><li><input type="checkbox"/> The battery (red) wire is not connected properly, check the battery terminals, and the battery wire.</li><li><input type="checkbox"/> If the charger is plugged in, the car will not turn on. Unplug the charger first before turning on the car.</li><li><input type="checkbox"/> Check the pedal switch if it is disconnected or defective.</li></ul> <p>The wheels are stuck and cannot move; check the wheels and motors if functioning properly.</p>
The car is moving slowly	<ul style="list-style-type: none"><li><input type="checkbox"/> If the battery is not fully charged, it will not run properly. Charge the car adequately for 8-12 hours.</li><li><input type="checkbox"/> Check the wheels and motors. Inspect the gears on the wheels, and motors if they are functioning properly. If damaged, the car will not run accordingly.</li><li><input type="checkbox"/> The car has a maximum weight capacity. If the user weight exceeds the recommended weight, the car will not run at full speed.</li></ul>
The battery does hold a charge	<ul style="list-style-type: none"><li><input type="checkbox"/> If the charger is defective. The charger must be showing a red or green light depending on the status of the battery. If the light is not showing, changing from red to green, or staying one color, the charger may be defective.</li><li><input type="checkbox"/> The battery life has deteriorated. Please use a voltmeter to verify the voltage post-charge. If it falls below the standard voltage amount, please replace the battery.</li><li><input type="checkbox"/> If the charging port between the charger and battery is defective. The charging port provides electricity output between the charger and battery. If the charging port is defective, then the battery can not charge.</li></ul>