



# Tropical beef production manual

Contact:

Meat & Livestock Australia  
Level 1, 165 Walker Street  
North Sydney NSW 2060  
Ph: 02 9463 9333 Fax: 02 9463 9393  
[www.mla.com.au](http://www.mla.com.au)

Published by Meat & Livestock Australia Ltd  
ABN 39 081 678 364  
June 2011

© Meat & Livestock Australia Ltd 2011

ISBN 9781741915792

Care is taken to ensure the accuracy of the information contained in this publication. However MLA and the contributors to this publication cannot accept responsibility for the accuracy or completeness of the information or opinions contained in the publication. You should make your own enquiries before making decisions concerning your interests. MLA accepts no liability for any losses incurred if you rely solely on this publication.

The inclusion of trade or company names in this publication does not imply endorsement of any product or company by MLA or any contributor to this publication. MLA and the contributors to this publication are not liable to you or any third party for any losses, costs or expenses resulting from any use or misuse of the information contained in this publication.

Meat & Livestock Australia acknowledges the matching funds provided by the Australian Government to support the research and development detailed in this publication.

Reproduction in whole or part of this publication is prohibited without prior consent and acknowledgement of Meat & Livestock Australia.



# Module 1

## Planning a tropical beef enterprise



Contact:

Meat & Livestock Australia  
Level 1, 165 Walker Street  
North Sydney NSW 2060  
Ph: 02 9463 9333 Fax: 02 9463 9393  
[www.mla.com.au](http://www.mla.com.au)

Published by Meat & Livestock Australia Ltd

ABN 39 081 678 364

June 2011

©Meat & Livestock Australia Ltd 2011

ISBN 9781741915792

Care is taken to ensure the accuracy of the information contained in this publication. However MLA and the contributors to this publication cannot accept responsibility for the accuracy or completeness of the information or opinions contained in the publication. You should make your own enquiries before making decisions concerning your interests. MLA accepts no liability for any losses incurred if you rely solely on this publication.

The inclusion of trade or company names in this publication does not imply endorsement of any product or company by MLA or any contributor to this publication. MLA and the contributors to this publication are not liable to you or any third party for any losses, costs or expenses resulting from any use or misuse of the information contained in this publication.

Meat & Livestock Australia acknowledges the matching funds provided by the Australian Government to support the research and development detailed in this publication.

Reproduction in whole or part of this publication is prohibited without prior consent and acknowledgement of Meat & Livestock Australia.

# Module 1

## Planning a tropical beef enterprise

This module outlines the physical issues involved when deciding to start or expand a beef cattle operation in South-East Asia. These issues include selecting suitable types of animals for the climate and market, and selecting a suitable location when establishing a new enterprise. Details of pen and yard design are given for the smallholder with up to five animals and for the larger operation run by a producer group or by an individual.

### Contents

<b>Introduction</b>	2
<b>Planning a tropical beef enterprise</b>	2
Type of production	2
Farm location	3
Road access	3
Soil types and area available	3
Rainfall and water courses	3
<b>Animal Environment</b>	4
Heat stress	4
Cooling	4
Shed and pen features	4
Pen cleaning	5
Bedding material	5
<b>Sheds for fewer than five animals</b>	6
<b>Sheds for the larger farmer or beef group</b>	7
Yard facilities and design	7
Ramps and races	10
Gates	11
Yard posts	12
Crush and head bail	12
Water troughs	12
Feed troughs	13

## Introduction

This module outlines the general and physical issues involved when deciding to go into beef cattle production in South-East Asia. These include selecting suitable types of animals, location and yard design.

There are many types of beef enterprises including breeding operations to produce calves and fattening operations to grow out young stock for slaughter or for the feedlot.

However, this manual is concerned with the smaller operators. Some may keep only one or two head, while others may have twenty or more, or be part of a beef-producer group.

Some producers may start with small-sized, but well adapted local animals and breed up from these. As there is often a shortage of suitable local females for breeding, government-sponsored programs may supply larger imported heifers for breeding.

Both local and imported types of animals are suitable for breeding. The local breeds are small and may not gain weight so quickly when fed high energy rations but they require less feed each day and are very well adapted. Females may have problems at calving if mated to large imported bulls. The imported breeds have higher genetic potential when given enough quantity and quality feed but may need 50% more forage each day. Both types can become easy to handle when trained with constant human attention.

Whatever the breed, the new cattle farmer has to deliver the type of animal that is wanted by the local market. For this, they have to know the customers' requirements or specifications and be able to assess a live animal as suitable for this market.

The principles of animal selection and breeding, cattle nutrition, husbandry and health and forage establishment and management are covered in Modules two to six.

## Planning a beef enterprise

For most small operators, the land used will be their existing farm or homestead. However, an outside operator wishing to invest in a new beef enterprise must consider many factors such as location and environment which can have an over-riding impact on profitability.

### Type of production

Cattle may be fully stall-fed, grass-fed or a combination of both.

Animals kept in stalls or small feedlots require less area than a grazing operation but there must be year-round access to suitable land for growing or harvesting fodder. Grazing operations can be more remote because cattle can be walked to an access road.



*Brahman types. Larger bodies need more feed.*



*Smaller local cattle – well adapted and easy to handle.*



*Purchasing cattle from the local market.*



*The farmer needs to select the breed that will provide what the market demands.*

## Farm location

The investor-operator has to choose a new farm with access to markets, suitable land and in a climate suited to the system of production. Larger farms should not be near water courses, lakes or dams to avoid pollution of water supply, and preferably not close to noisy factories, airports or busy motorways.

While cattle can graze over very varied topography, the cattle yards need to be on reasonably level land with good drainage.

## Road access

The farm should have good road access to the yards if trucks have to deliver or remove livestock or feed. The farm access road may need to be upgraded for slope, drainage and sharp corners while turning areas for trucks at loading ramps will need to be filled with road base.

The entry and exit to the yard should enable the truck driver to see other vehicles approaching from any direction. This will allow the driver to move onto the road slowly so that animals do not fall over. The entry road should not slope so much that the truck could roll over if all the cattle move to one side.

## Soil type

Land for yards, animal housing, sheds and loading ramps needs good drainage and stable soil. Land for growing fodder crops should have good structure and soil fertility. Many tropical soils are acidic and of low fertility; forage production can be improved with animal manure from feeding sheds or with purchased artificial fertilisers.

## Area available

The farm should have enough land to hold all the buildings and to grow the forages and crops needed to feed all the animals every day they are on the property. Typical carrying capacity for sown pastures is discussed in Module 6. Smaller areas can still hold a number of animals if feed and forage is purchased.

## Rainfall

Some regions receive rainfall throughout the year, other regions are seasonally dry. In nearly all cases, rainfall is heavy and intense when it does fall. Good distribution of rainfall enables forages and pastures to be grown throughout the year, whereas feed must be conserved and stored if there is a strong dry season. Intense rainfall must be diverted away from yards or sheds, and manure and effluent must be managed to prevent contamination of the environment or used to improve crop growth.

## Watercourses and water storage areas

Drainage from yards or cattle sheds must not be allowed to run into existing water courses (drainage gullies, creeks and rivers) or water storage areas. Dams or storage ponds should have suitable by-wash structures to prevent failure during heavy rainfall.



*Animals may be fed entirely in pens or allowed to graze.*



*Farms should have good access with all-weather roads*



*Intense tropical rainfall must be diverted away from yards.*

## Animal environment

### Heat stress

High temperatures and high humidity can cause heat stress in livestock (Figure 1.1).

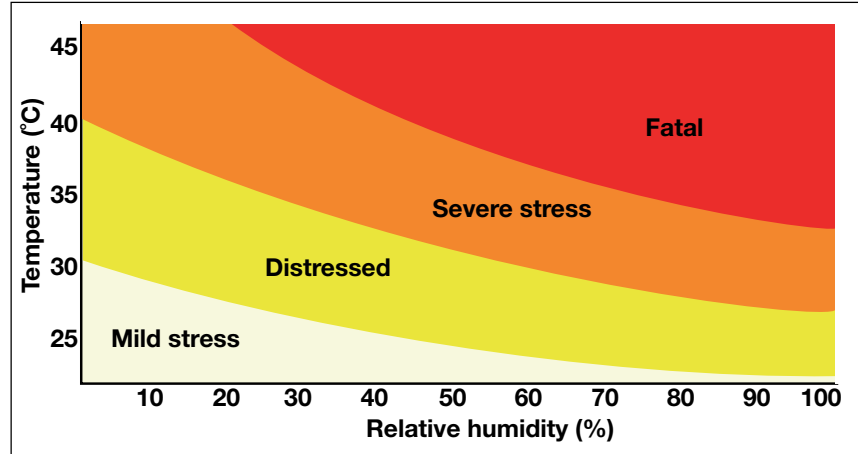

Figure 1.1. Degree of heat stress is related to the ambient temperature and the relative humidity.

The risk of heat stress is reduced by growing tropically-adapted cattle, by providing shade and by allowing natural breeze to blow through the shed or pen.

Heat stress produces observable changes (Figure 1.2) in behaviour but some physiological changes occur within the animal.

The amount of metabolic heat that an animal produces, how much heat it receives externally and how effectively it can transfer heat from its body is influenced by:

- coat colour – black coats absorb more solar radiation
- coat type – the dense flat coats of tropical zebu cattle can radiate more heat than the woolly coats of temperate European breeds.
- temperament – quiet animals generate less heat
- activity level – active cattle generate more metabolic heat
- diet – cereal grains produce more metabolic heat than forages
- previous exposure to hot conditions – cattle need at least three weeks to acclimatise

### Cooling

The most effective cooling comes from a natural breeze; side walls should not obstruct the winds prevailing at the hottest time of the year.

### Shed and pen features

Factors to be considered when designing sheds include the orientation of the shed to make best use of:

- prevailing winds
- sunshine reaching the floor at different times of the day and in different seasons (Figure 1.3.)

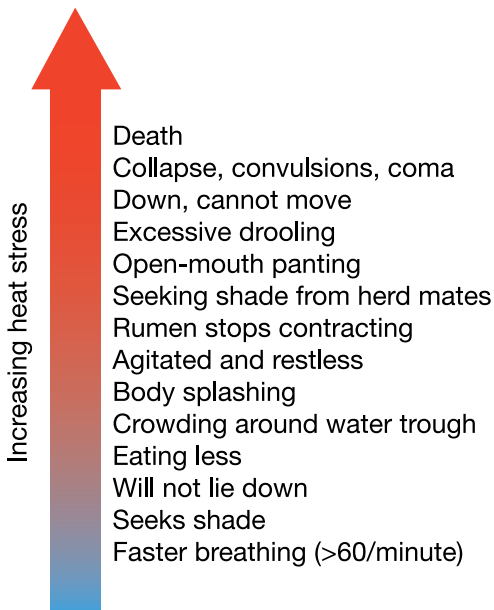

Figure 1.2. Signs of heat stress



Roofing should provide shade for stock and protect troughs against rain.



A roof from local materials is cheaper to erect and provides better insulation than tin or tiles, but will need to be replaced periodically.



- The shed should be aligned north–south so that the floor can be dried by morning and afternoon sun while the animals are protected from the intense noon sun and heavy rain.
- The roof should be at least three metres in height for good ventilation. Thatch is cheaper and cooler than iron sheeting but needs regular maintenance. Clay tiles are also suitable.

Other features for the shed or pen include:

- The floor should be raised and rammed hard, or with round logs set above ground level if is not cemented.
- Allow 3–3.5 square metres per head.
- The feed trough should be 150mm above the ground, 500mm wide and 300mm deep, and large enough to hold 40–60kg of green material. Allow 600mm in length for each animal.
- Strong corner posts 3 metres from the trough allow cattle to be tied in their stalls and individual animals to be quietened in the cattle shed.
- In a larger breeding operation, a calf pen (creep pen) should be constructed so that only small animals can reach their more nutritious, and more expensive, calf starter ration.
- Where smouldering fires are used at night to keep insects off the cattle, the fire must be outside the stall rails so the cattle cannot lie in the hot coals or ash.
- A covered manure pit or compost heap should be close by so that the stall can be cleaned easily and the manure quickly stored and composted. A covered pit or heap also helps to reduce the fly population.

### Pen cleaning

Pens should be cleaned regularly enough to help maintain the animal's wellbeing, control flies, reduce smell and to prevent the spread of disease.

Pens should be cleaned thoroughly and all bedding material removed when each group of animals is marketed. New clean bedding should be in place before new cattle arrive.

Where boggy patches appear in pens, the wet material should be removed and the reason for the bogging fixed before new dry bedding is placed.

Old bedding can be composted, used as fertiliser or sold.

### Bedding material

Bedding material is needed only in areas that are covered by a roof; it should be able to absorb the moisture from urine and dung, and be comfortable to lie on. Rice hulls, rice straw, sawdust or any similar local material can be used, but not corn stalks or sugarcane stems as these are not very absorbent and are uncomfortable for cattle to lie on.

When the bedding material cannot absorb any more moisture, it should be removed from the pen and replaced.

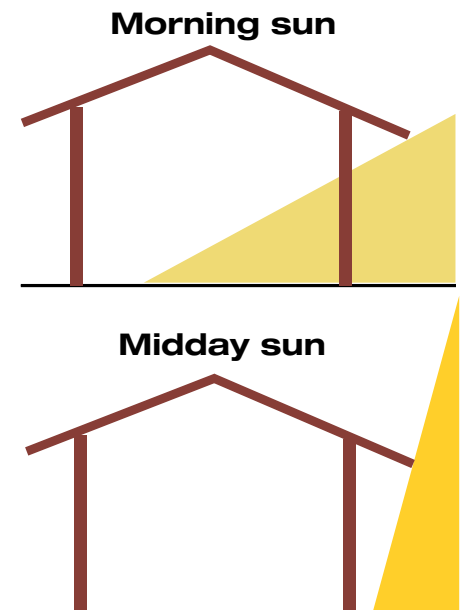

Figure 1.3. Shed orientation and roof overhang should allow entry of morning sun to dry the floor.



All sizes of pen should be cleaned out regularly (above), and clean bedding provided (below).



## Sheds for fewer than five animals

Many smallholder farmers have fewer than five animals. Some purchase animals from livestock markets; others may be provided with imported cattle through a government distribution scheme. Some imported animals may need extra handling and training before being taken to the farm.

### The small pen or shed

Many farmers with small numbers of cattle have pens built near or under their house. Because these animals are handled by the family every day they are usually very quiet and the pens can be less robust and made with local materials.

The shed provides:

- protection from sun and rain for the animals, reducing stress from heat and cold
- easier feeding with less feed wastage
- more personal attention and care to the animal
- protection against cattle theft

The farm pen or shed should be big enough for more than one animal, but if this is a heifer or cow, it may be preferable to cooperate with a neighbour to construct a shared cattle shed. Cattle are herd animals and are less stressed if they have a companion; also it is almost impossible to detect heat (oestrus) in a breeding animal if it is alone. (See Module 4 'Cattle Breeding for more information on heat detection'.)

Most farmers with small numbers of cattle keep their animals close to their dwellings. For those in villages, this often means that the shed is some distance from the forage area so the forage has to be cut and carried.

### Type of shed or pen

The type of construction will be determined by the availability of local building materials and the cost. The small operator usually uses local materials for construction and roofing. Rails can be of wood or bamboo; rails held in place with heavy wire (or rope) are more secure than those held with nails. Roofing can be of thatch, tile or iron sheets; thatch is often cooler but needs replacing periodically. Flooring may be concrete or wood and troughs of concrete or made from plastic drums.

The basic requirements of floor space and trough space apply to both small and larger sheds.



*The shed protects the animal from the weather (and theft), and allows for more personal attention and makes feeding easier.*



*Small sheds are generally made from local materials.*



*Grass and crop forage may have to be cut and carried from distant sources.*

## Sheds for the larger farmer or beef group

The larger farmer has more animals to take care of and needs to be more carefully organised. Housing and yards for sorting and handling need to be more robust with lower requirements for paid labour.

A stylised plan of a larger beef operation is shown in Figure 1.4.

The cattle shed should be:

- close to water
- close to fodder
- on slightly sloping ground with a raised sloping floor and drains at the rear and sides to redirect surface water



*A larger shed with sturdy roof and concrete floor.*

## Yard facilities and design

Any facility that is to handle, feed, house, water, and load or unload larger numbers of cattle should be specifically built and maintained for that purpose. Facilities must be strong enough to restrain the animals and to allow the farmer to do whatever husbandry practices are required. Whenever possible, local materials should be used if they are less expensive.

All obstructions and loose material should be removed from the yard. This includes logs and rocks and later any sticks, feed bags and plastic—especially plastic bags. These can cause injury to handler and animals if they fall over them, while cattle can die with obstructed rumens from eating plastic bags.



*The yard must be strong enough to allow the farmer to carry out whatever husbandry practices are required.*

## Village handling and breeding pen

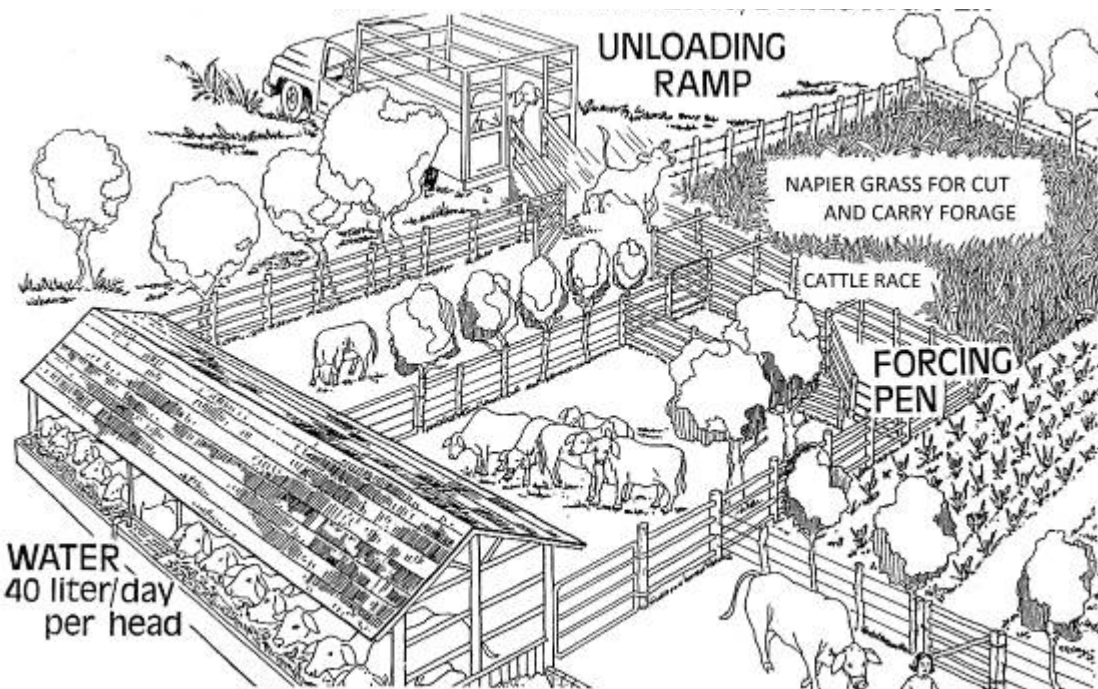

*Figure 1.4 . An example of a larger livestock farm.*

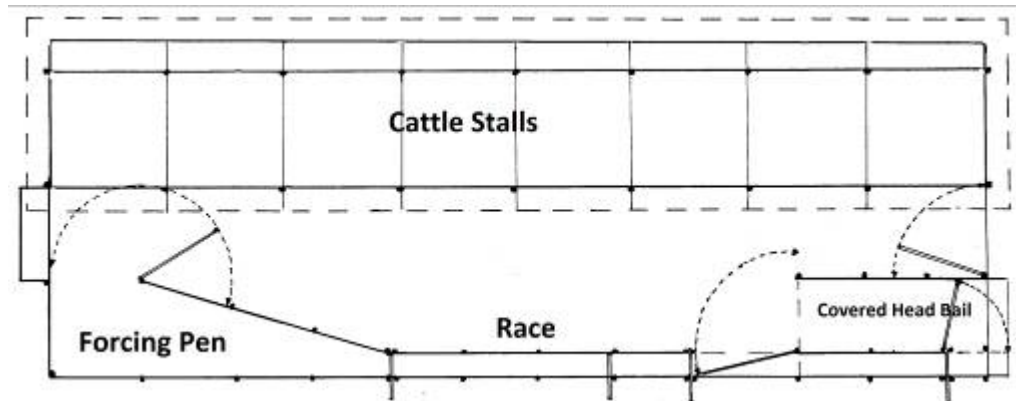
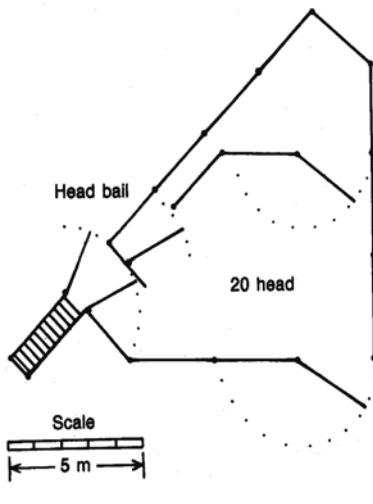

Figure 1.5. Simple design for stalls and handling

Figures 1.6 and 1.7 Examples of yard designs for loading and unloading, and drafting cattle.

There is little need to duplicate facilities such as loading ramps, crushes and races in a yard. In most cases, they can be used for a number of tasks if the yard has been well designed. Occasionally some minor modification or repairs to equipment may be necessary. Examples of layout and yard designs are shown in Figures 1.5 – 1.7.



Plan 1 can hold 20 head, but has limited drafting capacity. An additional yard can be erected on the offside of the race.

### Yard design and placement

All yards should be located on well-drained areas that will not become boggy in wet weather. Sometimes a layer of impervious material such as road base gravel may be needed over the selected site, with the thickness depending on the underlying soil.

Similarly, water pools and boggy patches should be drained and then filled with gravel.

Yards should be designed to make use of the animals' natural behaviour by eliminating tight or blind corners. This will speed up husbandry procedures and reduce the risk of injury to animals and people.

### Slope

Slope of the site has a large impact on all the operations. The yard site should have a slope of 3–5° to provide drainage, whereas flat land is often best reserved for cultivation of crops or forages. Steep slopes are likely to erode under heavy rainfall and should be avoided.

Changing the slope using bulldozers is expensive and needs to be well planned. Earth fill must not obstruct existing water courses or drainage systems.

Sites for buildings, yards or roadways should be compacted to prevent future bogging, erosion or slippage and to provide a firm base for buildings or sheds.

Gravel or rock may be needed if the base soil has high clay content while a gravel road base will prevent trucks from becoming bogged. Animals are easier and safer to work in yards that do not become boggy.

All water courses and drainage lines should be regularly cleaned and cleared of blockages. Failure to do so may lead to a build

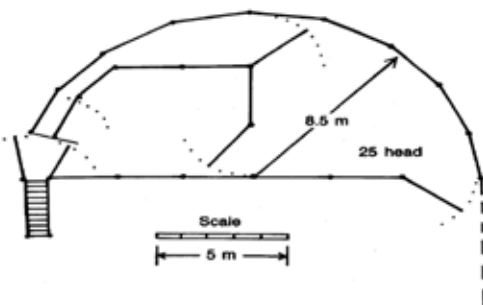

Plan 2 can hold 25 head, cattle work well around the curve, and worked stock can be retained.

up of material that may cause localised flooding, erosion, or the undermining of buildings or other infrastructure. Where drains have to be constructed, they should be wide, gently sloping (3° slope if possible) and grassed with a low-growing creeping grass.

## Shade

Shade will reduce heat stress on cattle in the yard, and up to 50% of the area could be covered. This is best done in strips facing north–south so that the ground can be dried by the sun as the sun moves east to west. Palm fronds or atap thatching is cheapest; other options are shade cloth, galvanised iron sheeting or clay tiles.

## Yard detail

Allow about 3.5 square metres per animal in holding or receiving yards and about 2 square metres per animal in the forcing or working yards. The top yard rail should be at least 1800mm high as low panels encourage animals to try to escape – often resulting in injury or death.

Rails should be spaced close enough to prevent animals escaping, with the lower rails closer together and lower to keep in calves. Examples of rail spacing for wooden and steel rails are shown in Figures 1.7 and 1.8.

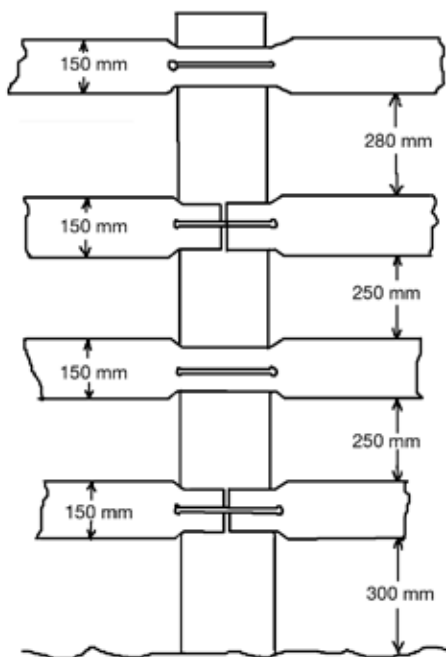

Figure 1.7. Wooden rails. Note the use of heavy gauge wire to hold rails to post

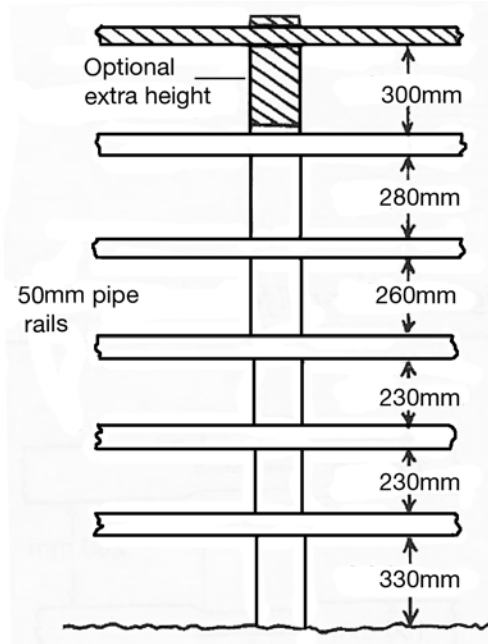

Figure 1.8. Steel rail spacing



Simple ramp and race for loading and unloading cattle.



Jumping a cow off a truck can result in broken bones.

## Loading and unloading ramps

Ramps should have a slope no greater than 20°. Ramps for unloading can be up to 3m wide, but loading ramps should be only 760mm wide to prevent mature cattle turning round.

The sides can be made from wooden rails, pipe or sheeting strong enough to stop the animals from escaping. Any sheeting on the side that the animal handlers work should only be to half the height to allow the handlers easy access to the animal.

The ramp should have a flat area at the top of about one metre in length, and its height should be the same as the floor height of the trucks for carting cattle. Check the floor height of local trucks before building the ramp.

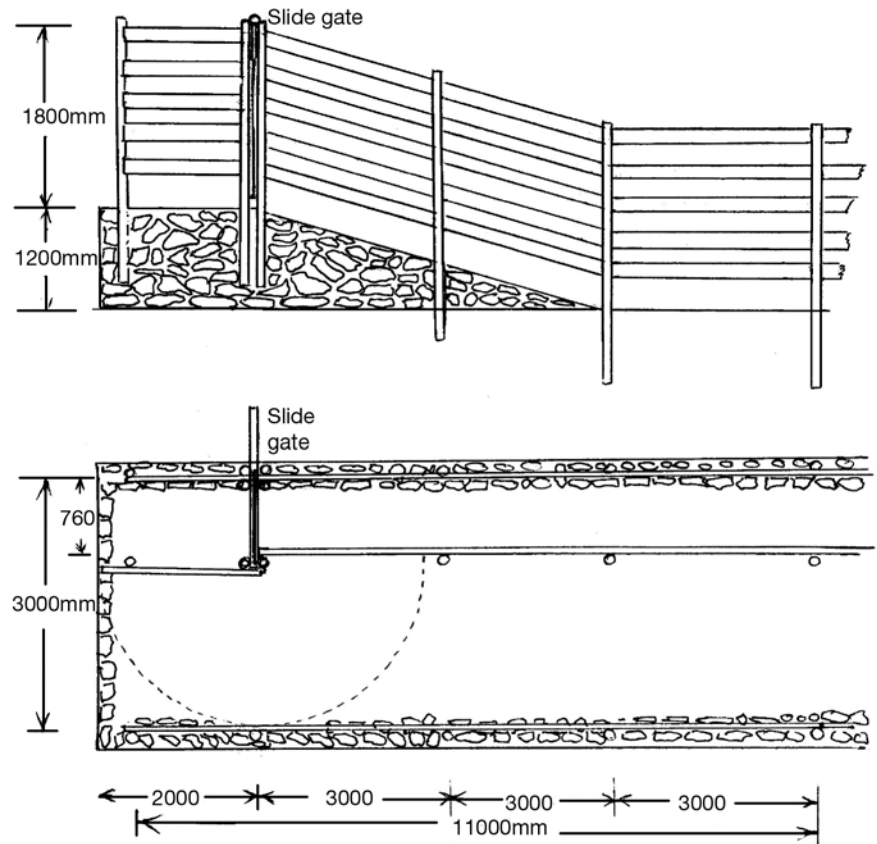

Figure 1.9 A design for a combined ramp for loading (760mm wide) and unloading (3m wide)

## Races

Where many animals are to be handled, the race should be of 4–5 panels each with a maximum length of three metres. On a small farm with less than five cattle, one or two panels would be adequate. The sides should be a minimum of 1800mm high of materials strong enough to prevent the animals from escaping. The race is 760mm wide inside.

As the race will be under pressure from animal movement, posts should be cemented into the ground 800–900mm deep. Thick-walled pipe is probably the easiest material to use but these should be capped or filled with cement to prevent them filling with water and rusting out.

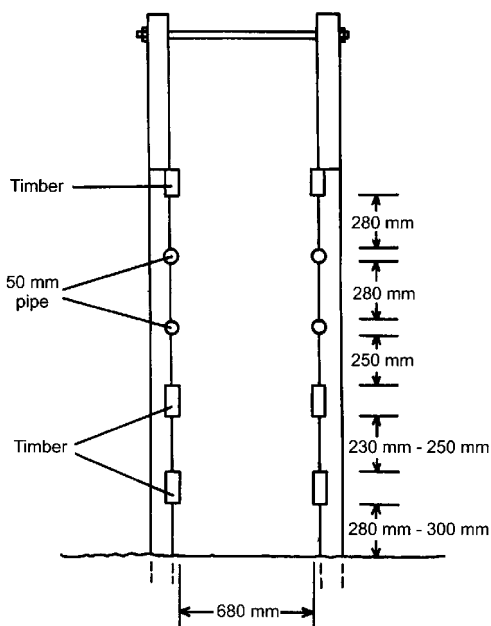

Figure 1.10. Race dimensions

The bottom one or two rails on the working side of the race should be removable so that animals can be released if they go down or turn over. All other rails should be secured or fully welded in place to give the race a smooth internal surface with a width of 760mm.

Details of race dimensions are given in Figure 1.10. The working area of the race should be covered to provide protection from sun and rain. Curved races and sheeting of fences in strategic positions make use of the animals' natural behaviour and allow animals to move more easily. This will reduce stress and injury to both animals and people, and remove holdups where animals can be distracted or attempt to join other animal groups.

### Laneways for the larger farm

Laneways should be planned to give animals quick and stress-free access to and from the yards, and to and from the pens or paddock. The width of the lanes will vary according to the amount of space available but preferably about six metres wide. Wider laneways need more handlers to control the animals.

Gates in laneways can also be used to assist handlers to move or control the animals with minimal stress or danger.

### Gates

Animals should be able to see where the handler wants them to go. Gates should be placed in corners so that animals move along a fence line and then through the gate; the fences assist the handler to maintain control of the animals.

The gates must be wide enough to allow a number of animals through together at one time. The gateway entrance to a yard need be only about 3000mm wide, and most other gates between 2000mm and 2500mm wide depending on the number of animals to be handled and where they are being used in the yard design.

Smaller gates 700–800mm wide allow handlers easy access—and quick exit. These should have a strong spring to ensure they are self-closing and to prevent animals becoming stuck in this small gap.

Examples of wooden and steel gate construction and gate latches are shown in Figures 1.11 – 1.14.



A roof over the working area gives protection from sun and rain.

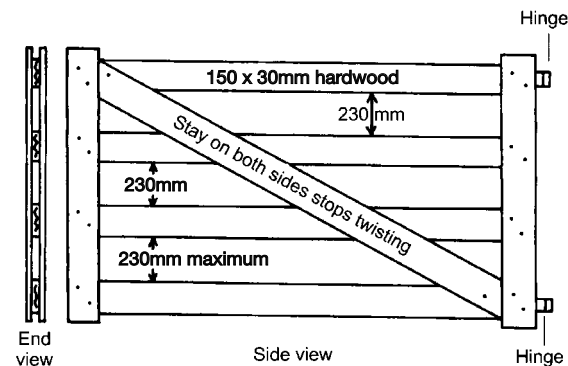

Figure 1.11. Dimensions for a wooden gate

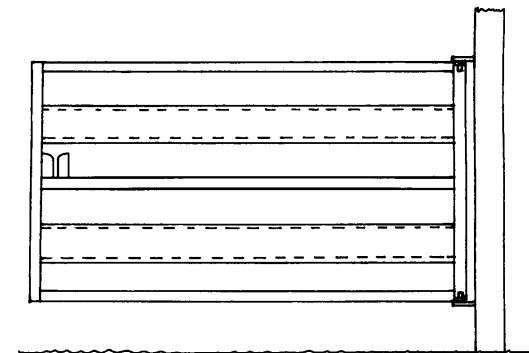
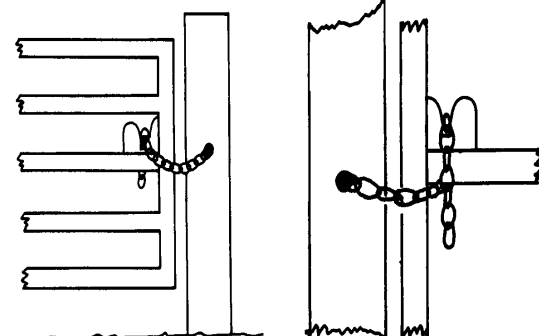
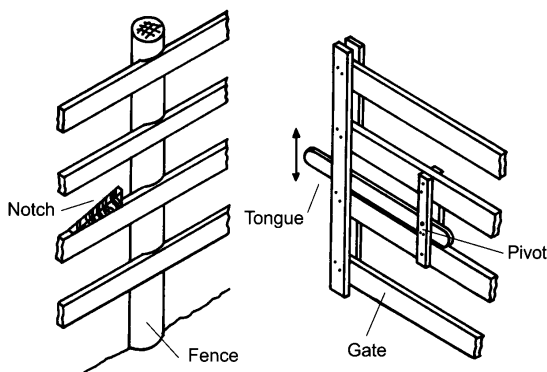

Figure 1.12. Dimensions for a steel gate



Figures 1.13 and 1.14 Details of latches for wooden and steel gates.



Posts without concrete collars will rust at ground level.

## Yard posts

Gateway posts should have a cap rail attached to prevent posts from spreading apart. The cap rail should be high enough to allow a person on a horse or tractor to drive under it. If the cap rail is made of pipe it can be bolted or welded to the gate posts. All pipe posts should be covered at the top or filled with cement to prevent them filling with water and rusting.

The base of all posts should be surrounded by a ring or collar of concrete to prevent rusting and rotting at ground level. This collar should be 200–300mm high and 200–300mm in diameter.

## Crush and head bail

A crush and head bail should be made of strong material capable of holding a large bull securely and safely. They are used for many procedures such as fitting rope restraints, inoculation, treating sick or injured animals, pregnancy diagnosis and artificial insemination.

Details of veterinary crushes and head bails are shown in Figures 1.14 – 1.17.

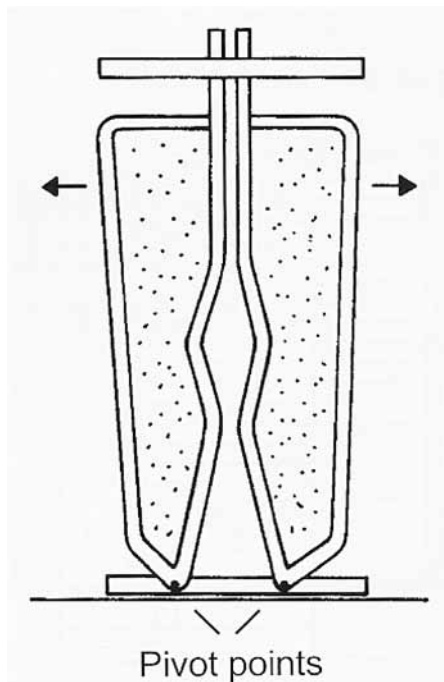

Figure 1.16. Design for a steel head bail

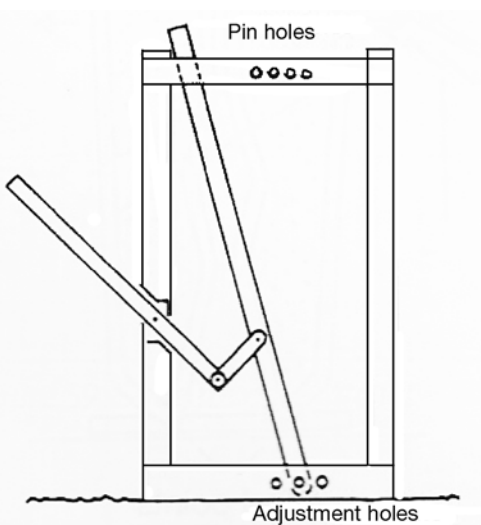

Figure 1.17. Design for a wooden head bail

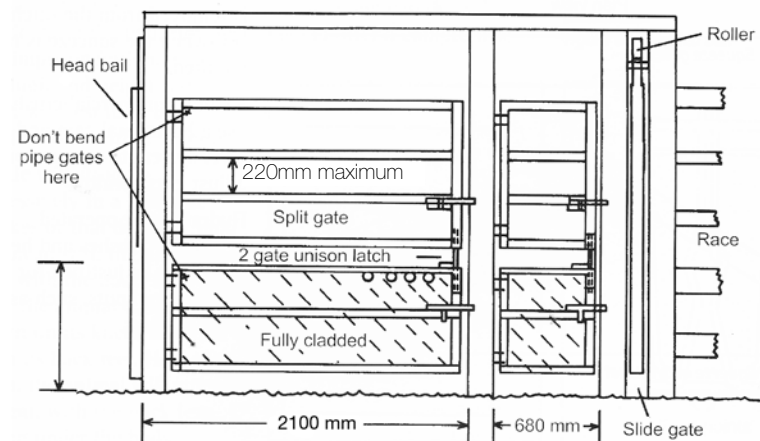

Figure 1.15. Diagram of veterinary crush

Some crushes may have electronic scales fitted under them so that the animals can be weighed at the same time that other management practices are being carried out.

## Water troughs

Water troughs should be placed only in the larger receiving yards. They are best placed in fence lines (Figure 1.18) so that animals in several larger yards can share the trough. The troughs must be solid enough to prevent animals getting into other yards or pens, but animals must still be able to drink easily from them.

Cattle will drink 30–50 litres per head a day depending on the temperature and humidity, and dry matter content of the ration being fed. Provide 50mm of water trough length for each animal.

Feed and water troughs should not be in the middle of yards (B) or where cattle can defecate, or walk or fall into them. This



will prevent contamination of feed and water, and spread of parasites and diseases. Where possible, troughs should not be in the corner of yards (C below).

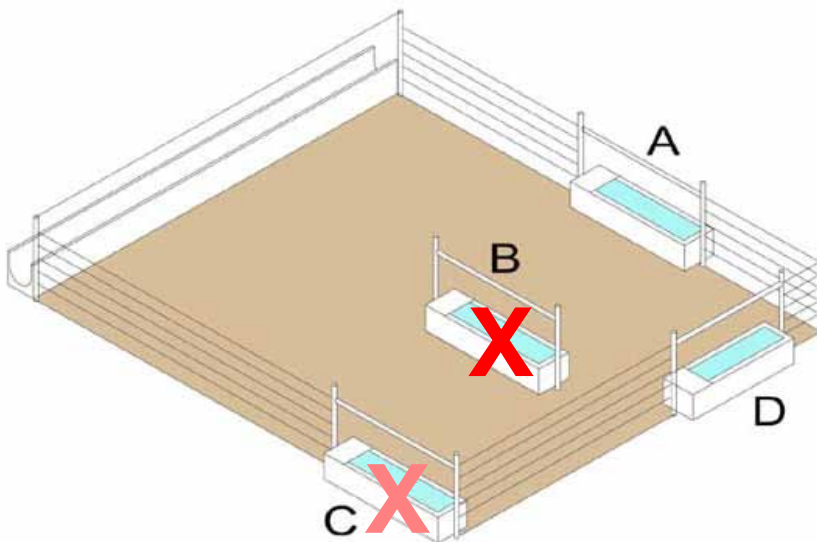

Figure 1.18. Water trough positions. Water troughs should be placed in fence lines (A, and D) and not in the middle of the pen (B), and preferably not in corners (C).

Water troughs should be cleaned regularly, at least once a week—or more often if water becomes fouled. Cleaning will remove any build up of dirt, algae or dung. A drainage outlet with a plug can make cleaning easy; the plug should be big enough to let the water drain out quickly but not leak.

Dirty water should be drained into a pipe and away from the shed. Waste water from cleaning should not be left in pools around the trough to cause wet, boggy areas.

## Feed troughs

Where roughages (grasses or crop residues) are to be fed, allow 600mm of feed trough length for each animal so that all animals can feed at the same time. Feed troughs should be outside the yard, but accessible to cattle through the rails, and under the shed roof to avoid feed spoilage from rain. Troughs should not be too high. Cattle should be able to easily get at the feed in the trough.

Feed troughs should be swept clean each day and uneaten feed thrown away to prevent it spoiling the fresh feed and reducing the animal's appetite.



Water troughs can be of concrete or plastic, but should be low enough for all animals to drink.



Feed troughs for forage can be made from local materials (above) but need to be more solid (below) if concentrates will be fed.





Level 1, 165 Walker Street, North Sydney NSW 2060  
Ph: +61 2 9463 9333 Fax: +61 2 9463 9393  
[www.mla.com.au](http://www.mla.com.au)



## Module 2

### Cattle nutrition for beef production



Contact:

Meat & Livestock Australia  
Level 1, 165 Walker Street  
North Sydney NSW 2060  
Ph: 02 9463 9333 Fax: 02 9463 9393  
[www.mla.com.au](http://www.mla.com.au)

Published by Meat & Livestock Australia Ltd

ABN 39 081 678 364

June 2011

©Meat & Livestock Australia Ltd 2011

ISBN 9781741915792

Care is taken to ensure the accuracy of the information contained in this publication. However MLA and the contributors to this publication cannot accept responsibility for the accuracy or completeness of the information or opinions contained in the publication. You should make your own enquiries before making decisions concerning your interests. MLA accepts no liability for any losses incurred if you rely solely on this publication.

The inclusion of trade or company names in this publication does not imply endorsement of any product or company by MLA or any contributor to this publication. MLA and the contributors to this publication are not liable to you or any third party for any losses, costs or expenses resulting from any use or misuse of the information contained in this publication.

Meat & Livestock Australia acknowledges the matching funds provided by the Australian Government to support the research and development detailed in this publication.

Reproduction in whole or part of this publication is prohibited without prior consent and acknowledgement of Meat & Livestock Australia.

# Module 2

## Cattle nutrition for beef production

One of the greatest limitations to livestock performance in South-East Asia is poor nutrition. A healthy, well-bred animal cannot grow, produce or reproduce to its potential unless it is receiving the appropriate balance or amount of nutrients. This module highlights the need for an effective feeding program in any livestock enterprise. It describes the components of animal feed—without the details of ration formulation—and how these need to be manipulated for the various classes of cattle.

<b>Contents</b>	
<b>Ruminant digestive system</b>	<b>2</b>
<b>Feed intake and digestibility</b>	<b>3</b>
Roughages and concentrates	4
Digestibility	4
Selection by animal	5
Forage processing	6
Speed of passage	6
<b>Essential parts of feeds</b>	<b>6</b>
Water	7
Energy	8
Protein	8
Urea supplementation	10
Minerals and vitamins	11
<b>Feed management</b>	<b>13</b>
How much to feed	13
What to feed	14
Crop residues	15
Crop by-products	16
Conserved feeds	16
<b>Appendix</b>	
Relative levels of nutrients in common feeds	18

## Introduction

The greatest limitation to livestock performance in tropical countries generally is poor nutrition. While animal disease is critical in some regions and genetics are important in any production system, a healthy, well-bred animal cannot grow, produce or reproduce to its potential if it is not receiving the appropriate balance or amount of nutrients. This module highlights the need for an effective feeding program in any livestock enterprise. It describes the components of animal feed—without the details of ration formulation—and how these need to be manipulated for the various classes of cattle.

All cattle need an adequate supply of good-quality feed if they are to grow and reproduce well. The main sources of feed for beef cattle are native herbage (from roadsides, communal grazing lands, forests), crop residues, and sown forages. Crop residues and native herbage may be readily available but they are often of poor quality; sown grasses and legumes are often the most economical source of feed.

## Ruminant digestive system

Cattle are ruminants and can digest food not suitable for humans or other animals with a simple, single, stomach. Ruminant stomachs have four compartments before the small intestine—the reticulum, the rumen, the omasum and the abomasum, each with a special function (Figure 2.1).

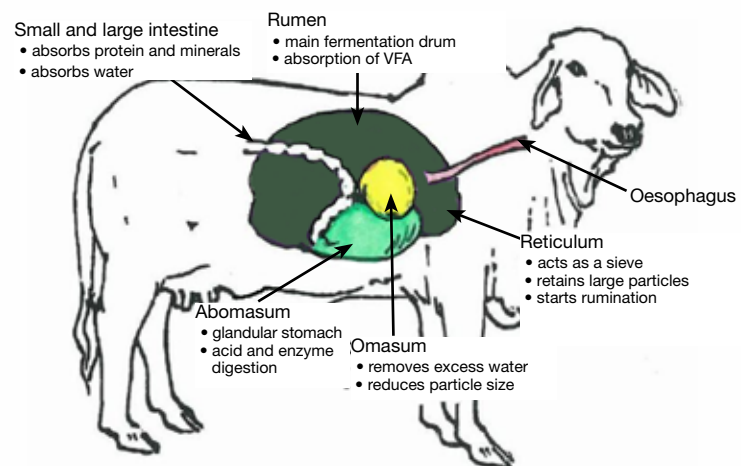

Figure 2.1. Ruminant digestive tract

Passage of feed

Mouth ↔ oesophagus ↔ reticulum → rumen  
→ omasum → abomasum → small intestine

Cattle pull leaves from growing plants with their tongues, then chew it slightly before swallowing it down the oesophagus into the reticulum. This material is later regurgitated back up into the mouth to be chewed again more thoroughly. This process is called rumination, and can be seen when the animals rest and chew their 'cud'. Rumination is stimulated by long fibres in roughage; chewing grinds down the fibres for better digestion and promotes the production of saliva.

The **rumen** is the largest of the four compartments. It holds fluid containing a range of bacteria, fungi and protozoa that break down the fibrous plant material into nutrients for their own reproduction. The rumen of an adult animal can hold as much as 200 litres of this rumen fluid. Movement of chewed feed and the overall efficiency of breakdown are assisted by contractions of the rumen wall.

Rumen fluid containing chewed, partly digested fibre and masses of the rumen microbes pass to the **omasum**. The omasum removes much of the water from the rumen fluid to increase the effectiveness of digestion in the abomasum.

The **abomasum** is a ‘true stomach’ which secretes digestive acids and bile. The microbes are digested and their protein, along with any ‘by-pass’ protein, is used by the animal; fats and remaining starch are also digested at this stage.

**Small intestine** and **large intestine**. The intestinal system in a ruminant is somewhat similar to that of a single-stomached animal. The small intestine absorbs minerals and proteins while the large intestine absorbs more water along with some energy components, proteins and minerals.

## Feed intake and digestibility

The more an animal can eat, the faster it will grow. But the amount it can eat will depend on how fast the feed it has already eaten can pass through its digestive system.

Thus the amount of feed eaten is affected by:

- feed quality
- rate of digestion
- rate of feed intake
- water intake

Other factors that can reduce intake include:

- not enough feed
- environmental stress, including heat stress
- limited access to water
- unpalatable plant species
- moisture content of feed—too wet grass after heavy rain; too dry grain concentrates
- mineral content of feed

Mineral content includes nitrogen, sulphur, sodium and phosphorus. Appetite is depressed when nitrogen concentration falls below 1.5%N (8–9% crude protein), sulphur deficiency leads to protein deficiency and reduced intake. Supplements of salt can increase intake of sodium-deficient pasture by 10–25%, and a phosphorus supplement can increase intake of phosphorus-deficient pastures by up to 25%.

For fast growth, the animal needs a balanced, high-quality diet.



*Forage is eaten and later regurgitated – rumination.*



*Animal resting and ruminating – chewing cud.*



*Cattle can eat more when the feed quality is good.*

## Roughages and concentrates

Feeds may be described as two broad types—roughages and concentrates.



*Roughage – rice straw*

**Roughages** are coarse feeds (high in fibre). Cattle need fibre for rumination but fibre can be digestible or indigestible. Good-quality roughages such as leafy grass and legumes can provide all of the animal's requirements whereas poor-quality roughages such as rice straw or palm fronds will not maintain bodyweight.

**Concentrates** contain one or more of the nutrients (eg protein, starch or minerals) in relatively high concentration, and are used as supplements to overcome any nutrient deficiency in the animal's overall diet. Cattle fed poor-quality rice straw need additional energy and protein—energy could be provided as cassava chips and protein as oil seed meal or legume leaf (see Appendix). Palm kernel cake is also high both protein and energy.

### Digestibility

The availability of a nutrient to the animal is expressed as 'digestibility'. In general, low digestibility means low intake.

The digestibility of a feed is largely determined by its lignin content. As plants grow older, the level of lignin in their stems increases; it gives strength to the plant fibres but is largely indigestible. The longer the period from one cutting or grazing of a forage to the next, the lower will be the digestibility of the plant material, and this will lead to reduced forage intake and poorer animal performance. Tropical grasses have more lignin than temperate species, and are less digestible. The optimal zone between maximising leaf and minimising stem is shown diagrammatically in Figure 2.2.

The fibre level in plants increases directly with age of regrowth, and in tropical grasses reaches a plateau after 2–3 months. Thus intake will decline as the grass matures and becomes less digestible. Most improved grasses have similar declines in digestibility but do so more slowly than annual native species that go to seed quickly.

While high levels of fibre in the diet depress productivity, some fibre of effective length (10–40mm) is needed to stimulate rumination and production of saliva to balance the acidity of the rumen. Insufficient effective fibre in animals fed some feedlot diets can result in the rumen fluid becoming so acidic that it upsets the animal's metabolism and may cause death.

### Leaf and stem

The stems of grasses have more of the indigestible lignin than the leaves; for example, the stem of elephant grass has 6–9% (of the dry matter) lignin, the leaf 3–4%. The proportion of stem increases with age. Elephant grass cut four weeks after the previous harvest is almost all leaf but green material harvested after 10 weeks is 50% stem. The pattern in legumes is usually less pronounced.



*Leucaena (lamtora) is the most digestible of all tropical forages.*



*Elephant grass harvested after 10 weeks is more than 50% stem.*



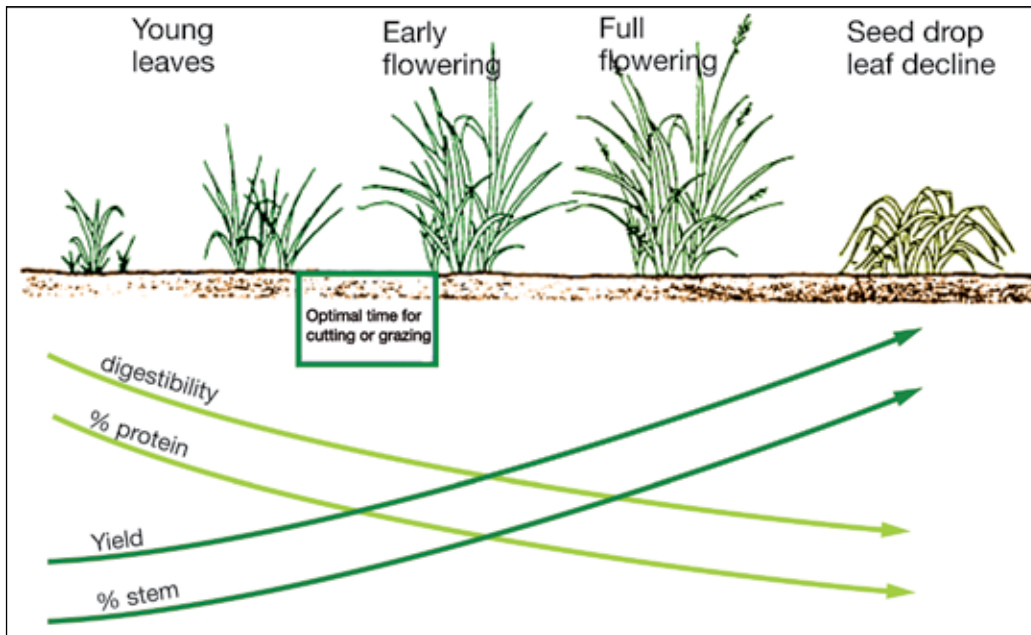

Figure 2.2. Yield increases with time, but digestibility declines. The best time to cut or graze grass forage is before it becomes 'stemmy'.

### Selection by the animal and palatability

An animal's intake can be affected by its ability to select its diet; it prefers green leaf to mature stem. Cattle can select a diet much higher in green leaf than the bulk of the pasture when grazing, but they may be forced to eat more old fibrous material when the same pasture is cut and placed in their trough.

Ruminants generally choose a mixed diet in a pasture but some plants are obviously unpalatable and rejected, and so become weeds. In a pasture of mixed grasses, animals may select one species over another, but without choice in a pasture growing only a less palatable species, they may be content to eat it.

Noone understands what makes one species more or less palatable to a ruminant but some species certainly have smells that appear desirable or undesirable to humans. Some palatable plants can be poisonous but generally cattle eat poisonous plants when other feed is limited.

### Eating behaviour

When grazing, cattle divide their day among grazing, drinking, walking, resting and ruminating. They may spend from 3–13 hours per day grazing, 6–8 hours ruminating (chewing the cud) and the balance resting but this will vary with the type of pasture and the season of the year.

In good quality pasture, cattle will be seen resting and ruminating whereas they need to keep grazing when grass is short or mature. In hot weather, many cattle rest at midday and graze in the cooler early morning and evening. *Bos taurus* cattle may seek shade while *Bos indicus* cattle are happy to graze in the sun.

Cattle in sheds or feedlots have different feeding behaviour from those grazing.



Young animal trying to select green leaf out of mixed quality forage.



Cattle eating the leaf of elephant grass while ignoring the stems on the right.



*Chopping is not an alternative to feeding good-quality, leafy grass.*



*Good feed for the smallholder – fresh, young grass with some legume leaf.*



*Good feed for the larger beef producer may be cut by machine.*

## Forage processing

- **Chopping.** Long grass is commonly chopped before being fed in a trough. While this can improve ease of handling and feeding out, it may force animals to eat more of the poorer quality stem material if they cannot select the leaf. Chopping is not an alternative to feeding good-quality, leafy grass.
- **Wilting.** The effect of allowing the leaf to dry after cutting appears to vary markedly depending on the species involved, the amount fed and the season. At normal supplementation rates, wilting or drying leaves has little or no effect on intake.

## Speed of passage

Low protein and high fibre in the diet mean that the rumen microbes cannot multiply quickly enough to digest the fibre. Thus protein deficiency also results in an energy deficiency. As little metabolisable protein is stored in the body, it must be fed continuously to be available.

When rumen efficiency is slow, the material stays in the rumen for longer. The amount of feed that an animal can eat depends on how fast the eaten food can move through the whole digestive system. When fed old fibrous material, digestion is slow, the animal can eat little new feed each day and its growth or production is poor.

If the rumen is full of very low quality fibrous material, ruminal contractions may stop and the whole rumen may become impacted; this may lead to death from starvation and metabolic disorder.

### Key point

The simplest, and usually the cheapest, way of supplying the animal with the correct balance of digestible nutrients is to provide it with a plentiful supply of fresh, young, leafy grass (up to 8 weeks' regrowth) and legume.

## Essential parts of feeds

All animals need suitable amounts of a range of nutrients if they are to remain healthy and achieve expected levels of production and reproduction.

The parts may be categorised as:

- **Water** (strictly not a nutrient, but an essential part of nutrition)
- **Energy** (energy is not a nutrient but is derived from various carbohydrates, sugars, fats, and proteins)
- **Protein** (protein, non-protein nitrogen)
- **Minerals** (macro and micro/trace minerals)
- **Vitamins** (implicated mainly in immune, hormonal and nervous system reactions)
- **Fibre** (the structural carbohydrate in plant cell walls)

## Nutrient balance

A key scientific principle is that ‘Growth is controlled, not by the total of resources available, but by the scarcest resource (the limiting factor).’ If one mineral is deficient, the animal cannot make full use of the other parts of the diet.

### Key point

All nutrients must be balanced. High levels of one nutrient do not compensate for low levels of another.

## Water

Water is not a nutrient but is vital for animal survival. Water provides all the fluid in the body—the blood supply, the digestive process (breakdown of nutrients, movement of feed through the digestive track, and in flushing the animal’s body of waste), the production of milk, and in regulating body temperature. Between 50% and 80% (for younger and older cattle) of the animal’s liveweight is water.

Many factors influence the quantity of water required by cattle.

- **Air temperature and relative humidity.** In hot weather, animals use more water for evaporative cooling. Their water intake doubles when daily temperatures increase from 21°C to 32°C.
- **Class and size of animal.** Cattle drink at least the equivalent of 5% of their bodyweight each day. On a fairly hot day, dry cows and bulls drink the equivalent of about 10% of their body weight, and growing cattle and lactating cows will drink the equivalent of about 20% of their body weight.
- **Water temperature.** In general, animals prefer water at or below body temperature; warm water reduces intake and thus animal production. Water troughs should be positioned in the shade where possible, and designed so that the water is replenished frequently.
- **Water quality.** Drinking water should be clean and fresh. Troughs should be drained and cleaned regularly; algae should be controlled as any unpleasant smell will discourage stock from drinking. Water supply should be checked at least twice daily and there should be least two days’ reserve of water available in case of supply problems. For cattle in pens, this reserve should be gravity-fed in case of pump failure.
- **Toxicity and contamination.** Sites of potential contamination or pollution include the source (bore, well, spring, dam, waterways) and storage tanks. The trough itself may become contaminated with feed or manure. Cattle should be prevented from drinking surface water in areas where there are snails and flukes. Irrigation water or run-off should be provided with caution as cattle have died from drinking irrigation water exposed to insecticide.



*Cattle must always have clean fresh water available —and be able to reach it.*



*Cattle grazing dry grass need more water than those on green grass.*



*Small-sized local cattle fed well are more profitable than poorly-fed large breeds.*



*No feed, no protein, no calf, no income.*



*Well-fed, large animals suited to the local environment offer best results.*

- **Feed quality and moisture content.** Stock on dry pasture need to drink more as there is less moisture in the grass. Fresh green pasture will supply some of the animal's water needs. Very wet and lush grass after rain may reduce intake.
- **Level of activity.** Active animals drink more.
- **Access to shade.** Cattle housed or under shade are cooler and so drink less.

### Key point

Good, clean water should always be available. Each animal needs 25–60 (up to 100) litres of water per day—even more if they are lactating).

### Energy

Animals need energy for most body functions and for work. Energy comes from the breakdown of basic components of feeds—carbohydrates, lipids (fats and oils), and proteins.

Cattle energy requirements vary with age, the stage of production, size of the animal, and expected performance. The animal first uses energy to maintain its body functions with any surplus used for growth, production or reproduction. Growing and lactating animals have a much higher energy demand than mature or dry cattle, and they often require extra energy when eating forage—especially low-quality stored forages.

### Measuring energy

Under the metric system, energy value of a feed is expressed as metabolisable energy (ME), measured in megajoules per kilogram of dry matter (MJ/kg DM).

Some older or US reference sources may show values as kilocalories (4.2 kilojoules = 1 kilocalorie).

### Protein

Proteins form the basis of all living matter, and therefore are an essential component of the animal diet. Much of the protein in the diet is broken down by the rumen microbes and reformed as microbial protein. The microbes are washed out of the rumen and are then digested in the abomasum to supply 50–100% of the animal's protein requirements.

The protein component of ruminant nutrition can be classified as:

- **True protein.** Protein that occurs in natural plant feedstuffs such as protein in plants, soybean meal, copra meal and palm kernel meal.
- **Bypass or protected protein.** True protein that passes undigested through the rumen to be digested in the abomasum. Bypass protein is digested more efficiently in the abomasum than if reformed as microbial protein in the rumen. Ruminants digest about 30% of their protein as bypass protein.

## Energy

In ruminants, energy is released from carbohydrates, lipids (fats and oils), and proteins through digestion by microorganisms in the rumen. Some 75% of the dry matter in plants is composed of carbohydrates, with different forms serving different roles in the plant.

These forms are broken down differentially in the rumen (Figure 2.7). Plant cell walls are made up of cellulose, hemicellulose, lignin, silica (and some protein), and become harder (more lignified) as the plant ages. Lignin is completely indigestible.

Plant fibres require more energy to break down and are generally digested slowly or are indigestible, and so are less efficient sources of energy for the animal.

The plant cells of green leaf contain sugars which are easily digested; starches are generally stored in plant seeds, roots and tubers, while oil is found in the seeds of some plants. Oils have a high energy content, but are generally expressed for commercial vegetable oil with the remaining meal available as animal feed. Too much oil or fat can upset the digestion of ruminants.

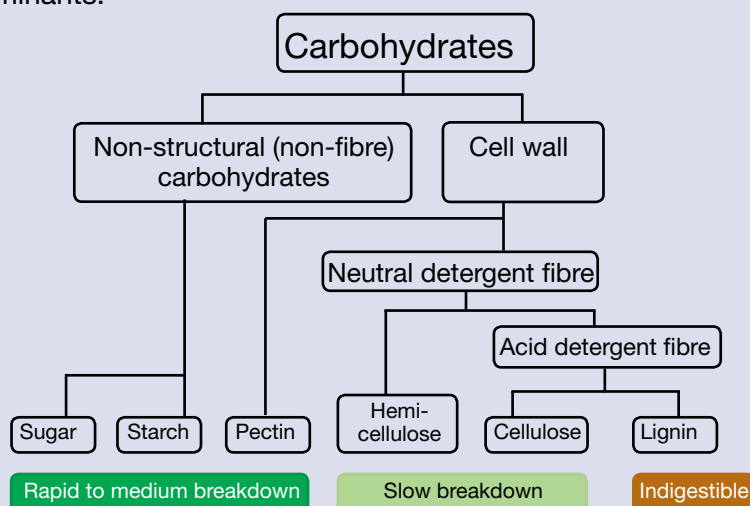

Figure 2.7. Digestibility of carbohydrate components of feedstuffs

- **Microbial protein.** The protein in the cells of the rumen microorganisms. Microbial protein can constitute 50–100% of the metabolisable protein requirements of beef cattle.
- **Non-protein-nitrogen (NPN).** Rumen microbes can use some mineral nitrogen in products such as urea to produce microbial protein—which is then digested by the animal.
- **Crude protein (CP).** Since ruminants can meet their protein needs from both true protein and NPN, these need to be assessed. As all proteins comprise about 16% nitrogen, their value can be calculated roughly by measuring the N% and multiplying that by  $100/16 = 6.25$ . This is known as the crude protein value.

The protein content of feedstuffs varies greatly, and relative values are shown in the Appendix. High levels of protein can be found in leaves and grains of legumes and in some by-products meals.

### Do not feed meat meal

Meat meal is also a source of true protein but must not be fed to livestock because of the danger of transmitting some viral diseases.

- Moderate levels of protein are found in cereal grains and young grass leaves and in by-products such as palm kernel cake.
- Crop residues such as rice straw have low to very low levels of protein.
- Grasses have lower crude protein levels than legumes at a similar stage of growth. Adding a legume to the diet can improve intake of a poorer quality grass.
- Protein levels decline as the plant matures, flowers and develops seeds—faster in stems than in leaf and faster in grasses than in legumes.
- Protein requirements of cattle vary according to the weight and type of animal, and its level of production. Growing cattle and lactating cows need more protein than mature or dry stock.
- Under the ‘Law of limiting factors’, if protein is deficient an animal cannot grow or produce well even though the diet has plenty of energy.
- For a balanced forage diet, it is best to feed fresh leafy grasses mixed with about 30% legume such as leucaena or stylo. Commercial protein concentrates can be fed but are usually too expensive for the smallholder farmer. However, some NPN can be fed—with caution.

Relative values of energy, protein and some minerals in some common feeds are shown in the Appendix.

### Urea supplementation

Urea is the most common source of NPN to supplement low dietary protein. Urea contains about 46% Nitrogen, and consequently has a crude protein value of 288% (46 x 6.25).

However, too much urea is toxic and will kill animals. It must never be fed to hungry animals without offering roughage first to fill the stomach. After this, small amounts of urea may be included (well mixed) in the ration.

#### – with some sulphur

Proteins also contain sulphur, and rumen microbes need some sulphur to make microbial protein.

A sulphur supplement may be needed by cattle when they are fed urea in conjunction with roughage low in sulphur. A nitrogen-to-sulphur ratio of 15:1 to 10:1 is recommended for urea supplements.

10g urea will increase the crude protein value of 1kg of rice straw by about 3%, and will need 1.5g of ammonium sulphate for a nitrogen to sulphur balance of 13:1.

Sulphur is found in ammonium sulphate (24%S), sodium sulphate (10%S), flowers of sulphur (100% S) or sulphured molasses (0.7%S as fed).

### Methods of feeding urea

Various methods have been developed to stop the animal eating too much urea too quickly.

#### Safe feeding of urea

Urea must be introduced to animals gradually over a period of two to four weeks to allow the rumen microbes to adjust.

It should not be fed at more than 30 g of urea per day in a single feed to animals not used to it and never fed to animals less than 12 weeks of age. Once adult cattle have adjusted, they can be fed 50–60 g urea/day.

### Lick blocks

- Cattle on poor quality feed can be given access to compressed blocks containing urea, molasses, salt, meal and some minerals. Commercial blocks tend to be expensive, so it is usually cheaper to prepare home-made mixes. Details of preparation and feeding of blocks are presented at <http://www-naweb.iaea.org/nafa/aph/faq-ummb.pdf>
- A standard urea–molasses–multi-nutrient lick comprises molasses (30–50%), urea (5–10%), cereal bran such as rice, wheat or maize bran (15–25%), an oil seed meal such as soybean meal, coconut meal or groundnut meal (10–20%), salt (5–7%), lime (5–10%) and minerals (1–2%). The multi-nutrient lick or block provides nutrients for both the microbes and the animal.
- A liquid mixture containing urea and molasses can be poured over low-quality roughage to improve its digestibility. The urea solution must be well dissolved before mixing with molasses.

### In case of urea poisoning

The commonly-used antidote for urea poisoning is vinegar. At the first sign of urea poisoning (convulsions), give the affected animal an oral drench of one litre of vinegar.

### Minerals and vitamins

Cattle need a number of minerals for growth, bone formation, reproduction and other body functions. Although the animals

#### Urea supplement — use with care

Feeding too much urea will kill animals.

Urea–molasses solution must be fed with roughages and not be given to cattle directly.



Hard commercial blocks of P and NPN can withstand rainfall.



Dry mixed P and NPN lick protected from rain.



Solution of molasses–urea is poured over rice straw to improve diet digestibility.

generally get enough minerals from grazing, common deficiencies include phosphorus, calcium and sodium. The mineral content in the plant varies with species, stage of growth and soil they are growing in.

Symptoms often associated with deficiency of these minerals in animals are shown in Table 2. 2.

Table 2.2. Some symptoms of mineral deficiency

Mineral	Symptoms of deficiency
Phosphorus	poor growth and milk production poor conception rates craving for bone, tree bark, wood, hair, soil
Calcium	poor growth bowed leg bones brittle bones
Sodium (salt)	poor growth chewing or licking of wood attracted to brackish water, saline soils
Magnesium	muscle tremors staggering, convulsions (grass tetany)



Compressed salt blocks can provide phosphorus and other minerals.

### Phosphorus (P)

Phosphorus is used in bone formation and in major metabolic functions throughout the body (carbohydrate, protein and fat metabolism, and nerve and muscle function). The P content of a plant is strongly influenced by the level of available P in the soil, and many acid tropical soils are low in available P.

Phosphorus levels in the diet can be increased in two ways:

- Fertilising the pasture with phosphatic fertiliser. While this will usually increase forage production and its P level, it is expensive.
- Feeding supplementary P using products including monoammonium phosphate (MAP), diammonium phosphate (DAP) and dicalcium phosphate (DCP). MAP and DAP also supply some additional NPN. Rock phosphate is not recommended as it often contains fluoride. The balance between dietary P and Ca must be maintained if using these supplements.

Legumes generally have higher levels of protein, phosphorus, calcium and magnesium than grasses in both leaf and stem. However, young leafy grass grown on fertile soil should have adequate mineral levels to good animal growth.

### Calcium (Ca)

Ca and P are the major mineral constituents of bone, and so Ca and P requirements must be considered together. Ca requirements change with age and production status of the animal. Although the ideal ratio of Ca to P in the feed is 1–2:1, production is not generally reduced unless the ratio exceeds 6:1. For grazing ruminants, Ca is generally adequate in forages, especially in legumes. If the forage is deficient in P, the Ca:P ratio widens, and a supplement of P is needed.



Ca deficiency can be induced in animals on marginal dietary Ca especially if they are grazing pastures dominated by specific grasses, including *Setaria sphacelata*, *Cenchrus ciliaris* or *Pennisetum clandestinum*. These grasses have high content of oxalic acid which locks up the calcium as insoluble calcium oxalate. Rarely a problem in beef cattle, it may be seen in high-producing dairy cows on low calcium soils (and in horses).

Magnesium deficiency may be associated with calcium deficiency in heavily lactating cows

### Sodium (Na)

Sodium or salt deficiency is relatively common in animals eating many of the tropical grasses and legumes. There are large differences in Na levels between grass species.

Provision of salt licks can greatly improve performance of animals on pastures low in Na.

### Vitamins

Fat-soluble vitamins are usually adequately supplied in fresh, leafy forage while bacteria in the animal's gut produce water-soluble vitamins. Panned cattle fed on bleached hay or straw can become deficient in Vitamin A.



Farmer feeding salt solution to attract his cattle.

## Feed management

### How much to feed

The simple answer is to feed as much good-quality feed as the animal can eat—and the best quality feeds are fresh leafy grass and legumes.

Feed quality has the greatest impact on intake as it influences the rate of passage of the feed through the rumen. Since different feeds have different moisture content, intake is usually expressed as the amount of dry matter consumed daily (dry matter being the weight of the feed after all the water is removed). Feed intake depends on the size of the animal, its condition, stage of production, milk production level, environmental conditions, and the amount and type of forage or feed offered, and its water content.

Table 2.3 shows some approximate relations between feed quality and the animal's weight, and is followed by worked examples estimating feed intake

Table 2.3. How much can an animal eat?

Forage quality	Example	Forage intake DM (% of body weight)
Low	Mature grass, crop residues	1.5
Average to good	Leafy grass (few seed heads)	2.5
High	Young leafy grass, legume	3.0



A 50kg stack of leafy grass—the daily requirement of a 450 kg animal for good production. Large imported cattle need much more feed each day than small local animals.



Reliable supplies of sown forage grass are needed for larger herds.



Grass cut from the roadside or waste land is of mixed species and quality but is cheap feed for a few animals.



Sown legume – stylo

*Example 1.* A 400 kg animal fed low-quality feed (60% moisture, 7% crude protein)

The animal can eat only 1.5% of its bodyweight as DM

$$\begin{aligned} \text{Amount of DM the animal can eat} &= 1.5/100 \times 400 \\ &= 6.0 \text{ kg} \end{aligned}$$

$$\text{Amount of green feed it can eat} = 6 \times 100/40 = 15 \text{ kg}$$

$$\text{Amount of CP it can eat} = 7/100 \times 6 = 0.4 \text{ kg CP}$$

*Example 2.* A 400 kg animal fed good-quality feed (75% moisture, 12% crude protein)

$$\begin{aligned} \text{Amount of DM the animal can eat} &= 2.5/100 \times 400 \\ &= 10 \text{ kg} \end{aligned}$$

$$\text{Amount of green feed it can eat} = 10 \times 100/25 = 40 \text{ kg}$$

$$\text{Amount of CP it can eat} = 12/100 \times 10 = 1.2 \text{ kg CP}$$

These two examples show the amount of crude protein in the animal's diet can be more than doubled simply by feeding better quality forage. Generally, if crude protein is adequate in un-supplemented forage, most of the other essential nutrients will also be in adequate supply. However, some minerals, particularly extra phosphorus, may be needed. The crude protein value of cut grass can be increased by adding legume.

## What to feed

### Forage grasses

Grasses are the most common ruminant feed. Tropical grasses have high feeding value when young (up to about 4 weeks' regrowth), but quality declines rapidly as plants mature (Figure 2.2). The temperate (cool season) grasses are of better quality (higher digestibility) and this quality lasts longer.

Leaving grass to grow taller before cutting or grazing may give more bulk but it is more fibrous and of poorer quality.

### Forage legumes

Different legume species can range from low-growing herbs, through creeping and twining types, to shrubs and large trees.

Legumes are generally more digestible than grasses and have higher protein contents. Adding even 5% legume to a diet of poor-quality grass can significantly improve animal performance. It is beneficial up to about 30% of the diet but feeding only legume is a waste of valuable protein.

The protein content of legumes declines more slowly than that of grasses as they mature, and so they are especially valuable at the start of the dry season when the feeding value of grasses falls. Deep-rooted legume shrubs and trees keep their green leaf during dry conditions.

Not all native legumes fix nitrogen and not all are palatable or suitable to feed to cattle. Some are less readily eaten when there is plenty of green grass available, some can cause nutritional problems. Lucerne and leucaena provide very palatable, high-quality feed but feeding too much lucerne (alfalfa) can cause bloat, while too much leucaena can cause goitre. Farmers need to be made aware of the problems and how to overcome them.

### Key point

Legumes provide high-quality feed that can be used to supplement poorer quality forage grasses and crop residues.

### Crop residues

Crop residues are commonly available sources of feed in mixed farming systems. They may be those parts of the plant remaining after a grain or pulse crop has been removed (rice straw, peanut hay), or green leaf and stem from plants supporting tuber crops (sweet potato vines, cassava leaf). While residues that still retain green leaf and stem may have reasonable feeding value, straw from grain crops have very little. These stems have very high lignin, while nutrients of sugar, starch or protein have moved from the leaf into the grain.

#### Rice straw

Large amounts of rice straw are produced each year, and much of it fed to livestock. Rice straw can be fed as a source of roughage in conjunction with higher quality feeds, but not as the major feed source. Rice straw is poor animal feed because:

- levels of lignin (6%) and silica (14%) make it indigestible
- protein levels are too low (2–6% CP) to sustain animals without addition of protein supplements or urea
- high levels of oxalate (1–2%) can adversely affect animals not getting enough calcium
- fine hairs on the leaf and sheath make it unpalatable
- it may become mouldy if stacked too soon after harvest while still partly green

Adding urea to make a straw silage can improve the feeding value of rice straw; the moist urea decomposes to alkaline ammonia which breaks down lignin and adds nitrogen. However this is still not widely used by smallholder farmers.

Table 2.4. Urea-molasses solution for treating 100kg of rice straw

Component	Quantity
Urea	1 kg
Water	10 L
Molasses	10 L

#### Cassava leaves

Cassava leaves provide a good source of protein, with CP levels over 30% of the DM. However, many 'bitter' varieties have a high level of toxic prussic acid (cyanide) in the leaf, and must be fed in limited quantities with roughages such as rice straw. Cyanide levels can be reduced by chopping and wilting the leaves and young stems for 12–24 hours before feeding to cattle.

#### Sugar cane tops

Tops normally comprise green leaves, the leaf bundle sheath and some immature cane. Most of the energy value as sugar has been transferred to the stem. Cane tops can be considered as only low-quality roughage and should be fed with higher protein such as a legume, or cassava leaf.



Sown legume - twining type



Adding a small amount of Glycidia leaf to poor quality feed can greatly improve intake and production.



The nutrition value of rice straw can be improved by composting it with urea.



*Soybean hulls. Most of the protein went into the bean.*



*Cassava leaf is high in protein but 'bitter' varieties can be toxic unless fed with roughages.*



*Crop by-product. Copra meal has high protein content but has to be purchased.*

## Crop by-products

Many extraction processes involving grains or oilseed produce considerable amounts of by-product that can be fed to livestock to provide one or more essential nutrients.

### Rice bran

Rice bran is nutritious, supplying protein, energy and minerals. However, full-fat rice bran has a high oil content that can lead to digestive upsets. The quality of rice bran is reduced by the low-quality outer rice husk that is mixed with bran.

### Copra and palm kernel meal/cake

These local oil seed meals are fed mainly as a source of protein for ruminants as they can be too indigestible for monogastric animals. They also contain essential minerals such as magnesium, iron and zinc but high levels of oil can upset ruminant digestion.

## Conserved feeds

The basic principle in fodder conservation is to preserve feeds from a period of excess production to feed to animals at a time of feed shortage.

The most common methods of conserving fodder are drying (hay and straw) and ensiling (silage). Valuable hay such as peanut hay is often stored under cover, rice straw or native grass is made into a rain-shedding hay stack while silage must be protected from rain or water runoff.

In the wet tropics, frequent rainfall and high humidity may make it difficult to cure hay reliably while hay made at the beginning of the dry season is often from forage of declining quality.

It is not easy to make good-quality silage on a small scale as the good fermentation requires more sugar than is generally found in tropical grasses. Also all air to be removed from the harvested material by compaction (usually with heavy vehicles). Farmers should seek advice before attempting it.

Ensiling a feed does not improve its quality—the final product always has a lower feeding value than the fresh product, unless additives are used.

A better strategy might involve augmenting the available low-quality crop residues and grass roughages with standover legumes, particularly drought-hardy legume trees, such as leucaena, glyricidia or sesbania.

### Key point

Good conserved feed cannot be created out of poor quality roughage.

### Summary

- Feeding is generally more important than breeding. A poorly-fed animal with good genetics is unproductive; a well-fed animal with average genetics can be very productive.
- Develop a feed-year plan that considers the limitations set by availability of resources (land, labour and finance) and the needs of the numbers and class of animals.
- Nutritional needs of cattle depend on their age and type of production.
- Nutritional value of forage depends largely on the stage of maturity of the plant and the species.
- The best source of feed is leafy, young forage.
- Animals perform best if they can select their own diet from forages.
- Adequate levels of ALL nutrients must be fed.
- Many crop residues are poor-quality feed, and need supplementing to provide balanced nutrients.
- Animals should have access to an unlimited supply of clean cool water.



*Drying legume leaf for high-quality hay*



*Silage is difficult to make well in small quantities, and must be protected from rainfall.*



*Green maize stover from crop of baby corn.*

## Appendix

Relative levels of energy, protein, calcium and phosphorus in common feeds.

Feedstuff	Energy	Crude Protein	Ca	P
<i>Roughages</i>				
Grass (4 wks)	●●●	●●●	●●	●●●
Grass (10 wks)	●●	●●	●	●●
Legume	●●●	●●●●	●●●	●●●
Rice straw	●	●	●	●
Sugar cane tops	●●	●	●	●●
Sweet potato vine	●●	●●●	●●	●●●
Oil palm fronds	●	●	●	●
<i>Energy concentrates</i>				
Cassava	●●●●	●	●	●
Molasses	●●●●		●	
<i>Protein concentrates</i>				
Palm kernel cake	●●●	●●●●	●●	●●
Copra cake	●●●	●●●●	●●	●●
Legume leaf meal	●●●	●●●●	●●●	●●●
Cassava leaf	●●	●●●●	●●	●●●
<i>Other</i>				
Rice bran	●●●	●●●	●	●

Rating

- very high
- high
- medium
- low



Level 1, 165 Walker Street, North Sydney NSW 2060  
Ph: +61 2 9463 9333 Fax: +61 2 9463 9393  
[www.mla.com.au](http://www.mla.com.au)



# Module 3

## Cattle husbandry, welfare and management





Contact:

Meat & Livestock Australia  
Level 1, 165 Walker Street  
North Sydney NSW 2060  
Ph: 02 9463 9333 Fax: 02 9463 9393  
[www.mla.com.au](http://www.mla.com.au)

Published by Meat & Livestock Australia Ltd

ABN 39 081 678 364

June 2011

©Meat & Livestock Australia Ltd 2011

ISBN 9781741915792

Care is taken to ensure the accuracy of the information contained in this publication. However MLA and the contributors to this publication cannot accept responsibility for the accuracy or completeness of the information or opinions contained in the publication. You should make your own enquiries before making decisions concerning your interests. MLA accepts no liability for any losses incurred if you rely solely on this publication.

The inclusion of trade or company names in this publication does not imply endorsement of any product or company by MLA or any contributor to this publication. MLA and the contributors to this publication are not liable to you or any third party for any losses, costs or expenses resulting from any use or misuse of the information contained in this publication.

Meat & Livestock Australia acknowledges the matching funds provided by the Australian Government to support the research and development detailed in this publication.

Reproduction in whole or part of this publication is prohibited without prior consent and acknowledgement of Meat & Livestock Australia.

# Module 3

## Cattle husbandry, welfare and management

This module outlines issues involved in managing beef cattle. It covers the important principles of animal welfare, communication between the handler and the animal, and training of new animals. The care and feeding of young calves is described, along with possible operations on the calf for easier and safer management.

<b>Cattle welfare and handling</b>	4
Animal Welfare Standards	4
<b>Cattle management</b>	4
Breed type	4
Determining age and weight	4
Conformation	4
Body Condition Scores (BCS)	5
<b>Trucking cattle</b>	6
<b>Restraining and training cattle</b>	8
Quietening the animal	8
<b>Communicating with animals</b>	10
Using the animal's vision	10
Flight zones	10
'Pressure and release'	11
<b>Calf management</b>	12
The new-born calf	12
Orphaned calves	13
<b>Husbandry procedures</b>	14
Dehorning	14
Branding	15
Castration	15
<b>Weaning</b>	16
Vaccination	16
<b>Record keeping</b>	17
<b>Appendix</b>	19
Making a rope halter	

## Cattle welfare and handling

### Animal Welfare Standards

All animal handlers should understand relevant Animal Welfare Standards set by the World Organisation for Animal Health (OIE). Unacceptable practices for animal welfare include hitting animals with implements that may cause pain or stress and making them agitated through excessive noise.

An animal owner and handler needs to understand some key principles for managing cattle.

#### Key points for good animal handling

- Domestic livestock are herd animals and like to follow a leader – guide this leader.
- Animals move away from strangers—their natural flight zones.
- Use an animal's senses (sight and sound) to change its direction.
- Handle animals in a balanced way to avoid harm, distress or injury.
- Aids such as the 'cattle talker' or rattles can be used to encourage movement of animals, but do not hit with sticks.

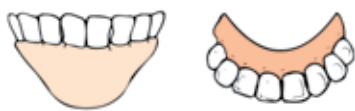

Birth to 18 months – milk teeth only; no permanent incisor teeth.

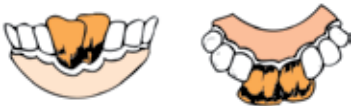

18 to 30 months – two permanent incisors.



24 to 36 months – four permanent incisors



30 to 42 months – six permanent incisors



40 months or more – eight permanent incisors

Figure 3.1. Cattle dentition and age

## Cattle management

### Breed type

Cattle farmers need animals that will survive, thrive and reproduce in their environment, and for which there is a local and profitable market. Zebu breeds (*Bos indicus* or *Bos indicus* crossbred) are more suited to the tropics and subtropics than pure European or British breeds; *Bos indicus* cattle are more tolerant of heat and humidity, can sweat more and are more resistant to ticks.

### Determining age

Calves are born with 'milk' teeth in the front of the lower jaw. As these are replaced by larger permanent teeth, the approximate age of an animal can be gauged by how many permanent incisor teeth are present. Two permanent teeth erupt at about 18 to 30 months, four at 24 to 36 months, six at 30 to 42 months, with eight ('full mouth') at 40 months or later (Figure 3.1)

### Determining weight

If weighing scales are not available, the weight of an animal can be estimated using a tape measure. (See page 16 for conversion figures for calves and weaners and for minimum weights for breeding females).

## Conformation

Productive and healthy cattle must be able to walk, forage, mate and calve without assistance.

### Legs

Common leg problems are:

- bow legs
- cow hocks
- sickle hocks
- post legs

These are illustrated from rear and side views in Figure 3.2.

A bull has to be structurally sound to be able to mount and mate successfully. Any bull with a structural problem should be culled.

Many structural faults are heritable and therefore will affect not only the bull but also his progeny.

### Feet

Lameness reduces the animals ability to walk around, to mate or to be mated.

Nearly all lameness in cattle starts in the feet. Muddy ground or soft wet bedding can further increase the incidence of lameness through sole injuries, infection of the skin around the hoof, and foot rot as the softened tissues are more vulnerable to bruising and injury.

Soft bedding and lack of walking may cause the hooves of penned cattle to grow too long, and overgrown or misshapen hooves may have to be trimmed. Examples of hoof structure and defects are shown in Figure 3.3.

## Body Condition Scores (BCS)

Body Condition Scores range from 1 (very thin animal with no fat reserves) to 5 (grossly over fat).

Cows have the best conception rates when their BCS is around 3. For profitable production, the aim is for the cow to produce a calf every year. Very thin cows will not get back into calf and their calves should be weaned early; very fat cows may not conceive and would have problems calving. Fat cows with BCS 4–5 are being overfed with expensive feed.

Minimum weights for heifers and breeding cows are listed on page 16.

Body Condition Scoring is described and illustrated more fully in Module 4. Breeding.

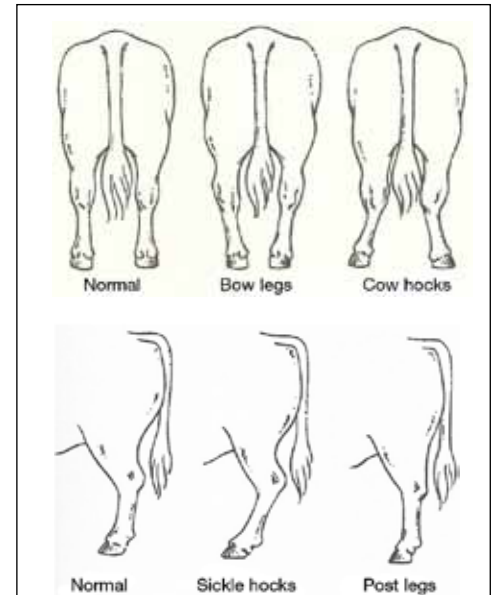

Figure 3.2. Common leg problems

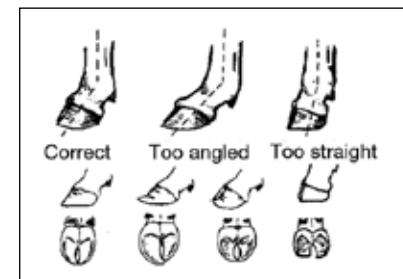

Figure 3.3. Common feet problems



BCS 1–2 – too thin to get into calf



BCS 3–4 – best condition for regular calving



Welded pipe cleats provide good footing and reduce slipping and injuries.



Steel mesh for reinforcing concrete is too light and tends to break up.



The sides of this truck are low for large cattle so a pole is tied across the animal's necks to stop them jumping.

## Trucking cattle

More cattle are injured while they are being transported than at any other time. Injuries occur on trucks because:

- there are no cleats/bars (30 x 30cm squares) on the floor of the truck to stop the cattle from slipping.
- there are holes in the floor
- there are nails or other sharp projections in the truck
- the truck sides are not high enough to prevent cattle scrambling over the side
- the back door comes open during transit
- drivers travel too quickly over rough roads
- too many or too few cattle are loaded onto the truck

Most trucks used to transport cattle are local multi-purpose general freight vehicles. These generally have some sort of back gate that requires strong physical effort to close quickly in order to prevent animals escaping during loading or unloading. Trucks with slippery floor surfaces should have cleats fitted to the floor; these can either be a lattice of wooden strips or steel rod or pipe at least 10mm in diameter. Reinforcing mesh is generally too light and breaks up. If cleats cannot be installed, the floor should be covered with sand or soft material such as coconut husks.

The truck should be inspected for sharp projections and for holes in the floor, and repaired before transporting cattle.

Generally cattle should be packed so that they can stand up again if they fall down. If the truck is overloaded, animals that fall cannot stand up and will be trampled. A pregnant heifer that falls will probably abort, and suffer severe stress. If the truck is underloaded, cattle will be thrown around unless the driver is careful.

Table 3.1 and Figure 3.4 shows a loading density guide for recommended per head space requirements at different weights.

Table 3.1. Recommended average loading rates for cattle of various live weights

Mean live weight (kg/head)	Floor area (m <sup>2</sup> /head)
200	0.70
250	0.77
300	0.86
350	0.98
400	1.05
450	1.13
500	1.23
550	1.34
600	1.47
650	1.63
700	1.81

Thus a normal 4 x 2 metre tray (8 sq. metres) will usually carry 10 heifers of about 250kg liveweight.

### Small Truck Load

9-10 head of 300-350 kg cattle  
or 8 head of 450-500 kg cattle

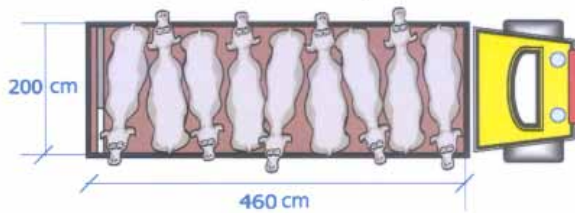

### Large Truck Load

16 head of 300-350 kg cattle  
or 13 head of 450-500 kg cattle

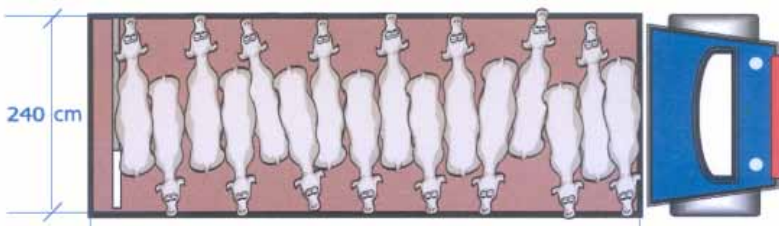

Don't load so many cattle so that they cannot move at all  
or so few so that they have no support when the truck moves.

Figure 3.4. Cattle densities for typical small and large trucks



The right way – truck tail boards with bars to prevent slipping, the loading ramp, high truck sides, good loading density and a pole to keep bodies tight.



Suitable loading density (Cattle may appear loose but the density is right).

## Key point

Drivers carting cattle should:

- drive smoothly
- avoid sudden acceleration and braking
- avoid pot holes

## Quarantine handling

If cattle are being trucked from a ship, they should be taken directly to quarantine. Extra loading and unloading only adds stress and the chance of more injuries.

On arrival at their new location, the cattle should be given clean water and the same feed as on the ship. The ration should be changed from pellets to forage slowly over four to five days by reducing the quantity of pellets each day.

Cattle being processed in quarantine should be divided into groups that can be handled in one day. In this way only a few of the animals are disturbed each day, without stressing the whole mob. From the quarantine area, the cattle are trucked to the farm or to a central distribution point.



On-farm biosecurity such as a lime foot bath will reduce the risk of new cattle bringing diseases such as FMD into an area.



*Nose ropes*



*Bulls tied up using halters (not a nose rope).*



*Farmer quietens his bull by washing and smoothing.*

## Restraining and training cattle

If cattle are to be handled individually by the farmer, they will need some system of restraint and control. This may be a head halter or nose rope.

### Halter

Larger diameter ropes give better control but no halter should be so tight that it cuts into the nose of the animal. A wide leather strap fitted under the nose halter will stop it cutting into the bridge of the nose. (See Appendix for how to make a halter.)

### Nose rope

To fit a nose rope, the animal must be restrained and a hole inserted through the septum (the cartilage wall separating the nostrils). A piece of rope the same diameter as the hole in the nose septum is then passed through this hole, run loosely up behind the animal's crown (ears and horn bumps) and from there tied firmly under the neck.

The lead rope is then tied off this nose rope at the point where the neck loop and the rope from the nose meet. In this way, there is no continuous stress on the nose but, when the rope is pulled from behind, it touches the nerves in the septum of the nose and the animal immediately stops. If the nose rope is tied too tightly, it will cut into the animal's nostrils barring the septum nerves. If the animal breathes with a roaring noise it indicates continuous pain due to the pressure on the nerves; this pain will enrage the animal and make it impossible to train or quieten. The animal will suddenly become quiet and docile when the ropes are loosened.

### Key points

- Use the nose rope for controlling a moving animal.
- Use the halter for tying the animal to post, rail or tether.

### Quietening the animal

1. Once the halter is properly fitted, the animal's head can be tied in the cattle shed to restrain head movement.
2. Push the animal against the side of the stall and fit a leg-rope (by lasso) to the outside rear leg so that the animal cannot kick. Brush the animal down using water to clean off manure. After a few days of this treatment, the animal will become quiet and easily handled, particularly if the person doing the grooming is also feeding it.
3. During this quietening period, talk quietly and avoid sudden movements.
4. At this stage, the animal can be taught to lead by being pulled forward by the neck rope while pressure on the nose rope will restrain it if it tries to run away. If the animal steps on a trailing nose rope, it will learn to stop as the rope pulls. Cattle can be led out to graze and tied to a peg.

## Daily routine

Cattle quickly adapt to routine and this makes them easy to handle.

Once the animal has been taught to lead, it can be taken out with the others to a common grazing area. The time out in the grazing area will depend on how much edible forage is available. If there is little, additional concentrate or cut-and-carry fodder must be fed—in the holding or pen area. If there is plenty of nutritious pasture, the animals can be left in the field for longer.

When the cattle return to their stalls they should have access to good quality leafy grass or other feed. They should be fed again in the morning before going out to graze.

This should be done at the same time each day so that a routine is established.

## Education and training

On small farms with only a few cattle, education begins soon after birth when the farmer or his wife tends the calf each day.

In larger herds, cattle are easiest to train at weaning, and this education will last their life time.

Calves should receive concentrates and supplementary feeds after weaning to introduce them to new feeds that may be offered later.

They should be quietly handled through cattle yards and in paddocks so that they learn to respect normal handling and management procedures, and fences.

Cattle should be held in yards only for the minimum time required so that handling becomes a positive experience.

## Reducing stress in handling

Well-designed yards based on an understanding of cattle behaviour (see Module 1) will reduce stress on both animals and handlers.

- Cattle that become excited and agitated may have levels of stress hormones in their blood up to three times higher than cattle handled gently and quietly.
- Stressed animals are a danger to themselves and to the handlers.



*On small farms, education of the animal begins at birth with regular handling and feeding.*



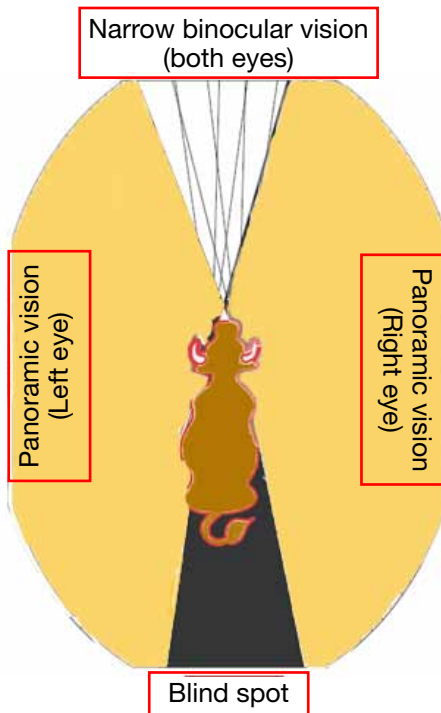

Figure 3.5. The handler uses the zones of the animal's vision to communicate with it.

## Communicating with animals

Communicating with animals is related to flight zones, mob structure and understanding their reaction to your position and movement.

Animals want to:

- move quietly without being rushed
- follow other animals
- be part of a mob — and not to be isolated
- see what (or who) is pressuring them

Cattle in a mob look for a leader—which may be another animal or a person.

### Using the animal's vision

Vision is the most important animal sense to use when communicating with livestock. The handler positions his body in relation to the animal's vision to influence its movement.

Animals have panoramic vision (see Figure 3.5), but cannot see directly behind. The handler should not stand in this blind spot as the animal needs to see him to know where he is.

### Features of its sight

- **Depth perception** – if the handler moves slightly, the animal may find it easier to determine the distance.
- **Illumination** – stock like to move from dark to light areas, and can be difficult to move into dark places.

Other livestock senses that need to be considered when working with animals are:

- **Sound** – excessive noise causes stress and should be avoided. Animals can be moved without noise.
- **Smell** – cattle become upset by strange smells or the smell of blood.

### Flight zones

The flight zone is the animal's safety or comfort zone. Its size is the distance an animal will allow a stranger to approach before moving away.

Cattle, such as dairy cows, that are handled every day have no flight zone and will allow an operator to approach and touch them; cattle that are unaccustomed to people will move away.

The flight zone size is determined by the amount of contact cattle have previously had with people, the quality of that contact, and genetics (temperament).

Temperament and experience interact to determine an animal's flight zone—flighty cattle may be tamed by gentle handling.

Calm cattle are easier to move but an animal's flight zone will increase if it is excited. It takes 20–30 minutes for them to settle down again.



These imported cattle have not previously had much contact with humans, and keep away from the stockman. Their large flight zone will be reduced by steady handling and close attention.

## Pressure and release

The four main principles of livestock communication are:

- **Position** — where the handler is in relation to the animal's eye.
- **Movement** — the handler moves his body position so that the animal sees him.
- **Pressure** — apply pressure to get the animals to move but then release it.
- **Communicating** — let the animal communicate with other animals in the herd.

Tools that can be used to create movement are:

- Human body – move to attract the animal's attention by either walking towards them or waving the arms
- Goads – the 'cattle talker' is a stick with a flapper on the end. Goads are seen as an extension of the body—they are NOT a tool to HIT animals.

Once the cattle are moving, release the pressure from attention-seeking actions (Figure 3.6).

An animal will not move if it has nowhere to go.

Livestock prefer to move in a curve, when going in and out of gateways and pens. Position yourself so the animals move around you, rather than blocking them.

Make it clear to the animals what you want them to do.

- Are you sending the animals the right message?
- It is difficult to communicate with an animal that is frightened.
- Do not penetrate the flight zone too deeply or too quickly when trying to create movement with frightened animals.
- Do your fellow workers understand what you are trying to achieve?
- Working together as a team will create more effective movement and livestock handling.
- Never hit an animal that is already moving in the right direction. Never hit or pressure an animal that has nowhere to go.

### Key points

- Cattle are herd animals and like to be with other animals.
- An animal can become frightened and more aggressive if isolated from the mob.
- Constant calm handling reduces the animal's flight zone from humans, making it easier to control.
- The handler uses his position in the animal's vision and flight zone to create pressure to move.
- Once the animal starts to move, the handler moves back to release pressure.

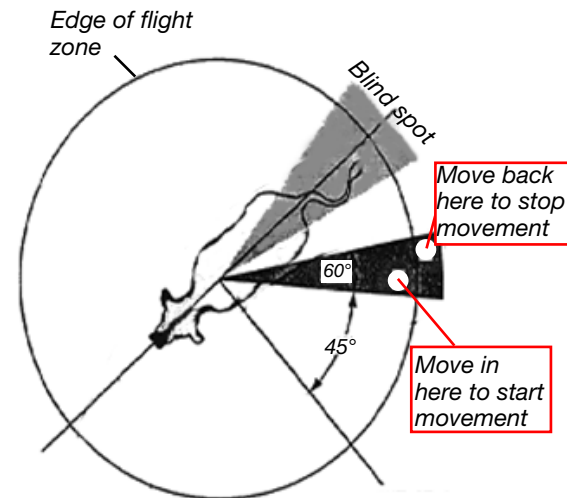

Figure 3.6. Pressure and release. Handler moves into flight zone to start animal to move, and then moves back when it does move.

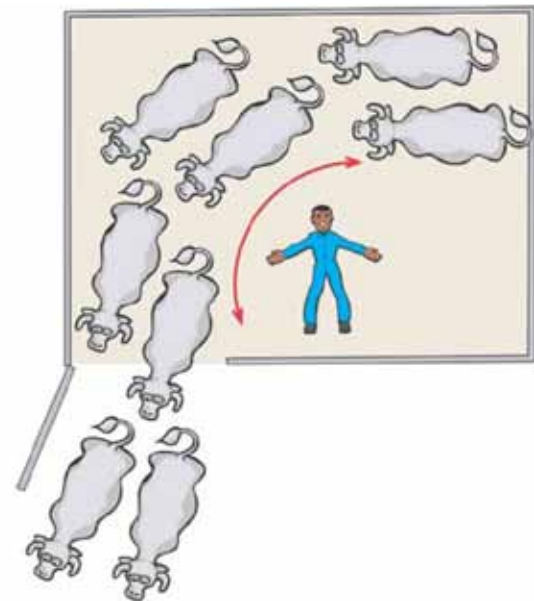

Figure 3.7. Cattle prefer to move in a curve so allow the animals to move around you.

## Calf management

An adult bovine has one stomach with four compartments — the reticulum, rumen, omasum and abomasum.

At birth, the calf's stomach is adapted to liquid food (milk) which passes directly to the abomasum. The rumen, for digesting grass and roughages, does not start to develop until the calf is about two weeks old (see Figures 3.8 and 3.9 and Table 3.2).

### The new-born calf

#### Drying the calf's navel

The calf's navel should be dry by about 48 hours after calving when the mother and calf are bonded and the calf is suckling normally. But to prevent infection or attack by screw fly, the navel should be dried by applying tincture of iodine.

#### Suckling

Healthy calves are generally on their feet within 30 minutes and suckling within an hour after birth. The calf should be allowed to run with its mother and suckle at any time if the cow is producing milk normally.

If the calf is kept separated from the cow, it should be allowed to suckle at least three times a day, and should always have access to fresh green roughage. When this is not possible or if the calf is weak, it is best confined to a pen.

At birth, the calf's stomach has an oesophageal groove through which the milk flows directly to the true stomach where it is digested efficiently. This groove is stimulated when the calf suckles but less so when it drinks from a bucket. If the milk leaks into the rumen, it will ferment and cause a digestive upset.

The rumen starts to develop when the calf eats grass or roughage at about two weeks of age. Table 3.2 shows the relative sizes of the parts of the stomach for a calf and for an adult animal.

Table 3.2. Relative sizes of parts of the rumen at different ages

Stomach part	Calf	Adult
Rumen	28%	80%
Reticulum	3%	5%
Omasum	3%	5%
Abomasum	63%	5%

### The importance of colostrum

Colostrum, the first milk produced by a cow after giving birth, contains high levels of antibodies, protein and vitamins that protect of the calf against disease.

A calf should receive colostrum from its mother for at least the first three days of life. If it does not suckle within 4–6 hours, it should be helped and force-fed from a bottle with a rubber teat. If the calf does not receive enough colostrum, its chances of survival are greatly reduced.



The new calf must get all its colostrum in its first two to three days of life.

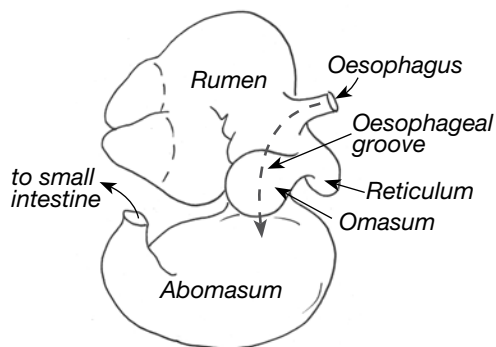

Figure 3.8. Stomach of new-born calf

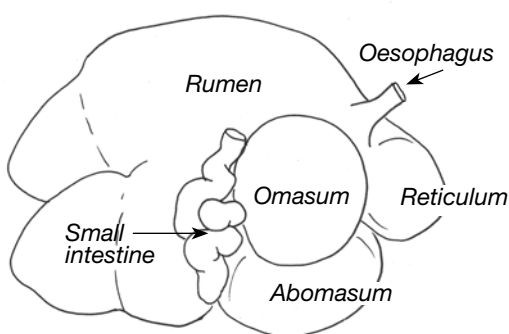

Figure 3.9. Stomachs of adult ruminant

## Feeding colostrum

If a cow refuses to allow her calf to suckle, she will need restraining during feeding periods. It may also be necessary to tie one rear leg to prevent her kicking, and to help the calf to feed. This should be done two or three times each day until the cow accepts the calf. The cow can also be hand-milked and the colostrum fed to the calf— preferably through a rubber teat so that it sucks rather than drinks. Sucking stimulates the oesophageal groove (see previous Section); if it drinks from a bucket, the milk may stay and ferment in the rumen, making the calf scour.

## Orphaned calves

### Colostrum substitutes

Colostrum substitutes are sometimes used but do not contain the antibodies that prevent infection. A basic recipe for ‘artificial colostrum’ is:

- 1 egg beaten
- 300mL clean water
- 2mL castor oil
- 600mL whole milk

Feed this mixture three times per day for the first three days.

### From Day 4 to weaning

The orphaned calf should be fed on milk or milk replacement until 3–4 weeks old (even up to 6–12 weeks) depending on the quality of feed available, the calf’s size, rate of growth, and health. Feeding milk through a teat allows the suckling reflex and causes less scouring than drinking from a bucket.

Calves normally start eating small amounts of forage and concentrate feed during the first week of life.

Good quality, soft-textured roughage should be available within the first week or two after birth to encourage development of the rumen. Fresh forage should be fed each day and old forage discarded.

Hand-reared calves should be offered a concentrate mix from about 1 month old. This concentrate mix must be palatable and high in energy and protein. An example of a good concentrate calf feed is:

- 40% ground corn
- 25% rice bran (fine, D1)
- 24% soybean meal
- 8% molasses
- 2% calcium diphosphate
- 1% rock salt

Liquid milk can be stopped once the calf is eating 0.5 kg of concentrate daily.

### Early training to lead

Calves should be halter broken and trained to lead before they are two to three months old, and become too big to handle.



*Feed colostrum through a rubber teat rather than from a bucket to close the oesophageal groove.*



Scoop and cup dehorners

## Husbandry procedures

### Dehorning

Horns should be removed to prevent injury to other cattle and to handlers.

It is best done when the calf is under three months old as this will cause no setback. Dehorning an older animal when the horn is attached to the skull is a major and painful operation (see box on the anatomy of the horn). Calves can normally be dehorned when two to three weeks old.

Common methods of dehorning are:

- scoop or cup dehorners
- dehorning knife
- hot iron

#### Key point

To make sure that the horn does not regrow, about 1cm of skin around its base should be removed (Figure 3.10).

#### Scoop and cup dehorners

With scoop dehorners, the scoops are placed over the horn bud and the handles pushed apart; with cup dehorners, the handles are pulled together. These actions bring the edges of the blades together and scoop out the horn bud.

#### The dehorning knife

The dehorning knife can also be used on calves two to four months old. Dehorning knives are available for left or right-handed operation.

#### Hot iron

Dehorning irons are similar to soldering irons but with a heavy cylindrical head hollowed out at the tip. Most types are heated using a gas ring or blowlamp, or the gas heaters used for branding irons but electric irons are available.

The calf is held firmly on its side (at this size, a cradle is not necessary), and when the iron is heated to a cherry red, it is applied firmly over the horn bud. A ring of tissue right around the bud is seared by twisting and screwing the iron around several times.

The burn should penetrate the full thickness of the skin. The wound is thus cauterised and will not become infected. The horn bud will drop off later.

Older calves (up to two to three months) need irons sized according to the size of the emerging horn.

#### Treatment after dehorning

After a cutting operation, animals may bleed freely for a short time; a proprietary wound dressing powder that contains a fly repellent should be applied if flies are a problem. With the hot iron, the wound is cauterised which reduces blood loss and dries out the wound.



Dehorning knife



Hot iron dehorner, internal diameter 25-30mm.

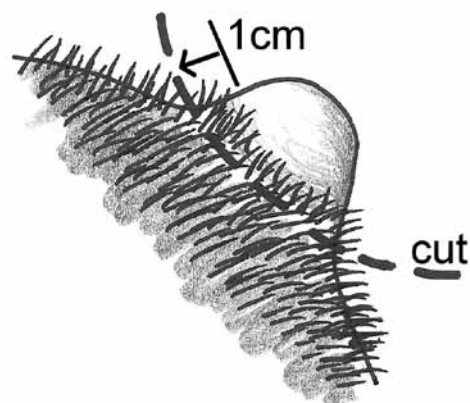

Figure 3.10. Cut away about 1cm of skin around the horn bud base to make sure that the horn does not regrow.

## Anatomy of the horn

In young calves, the horn bud is attached to the skin and not to the skull, and can be removed easily at this early stage (Figure 3.11). As the animal matures, the horn core becomes a bony extension of the skull with a hollow centre communicating directly with the sinuses of the skull (Figure 3.12).

Dehorning a large and older animal is messy, painful, and time-consuming.

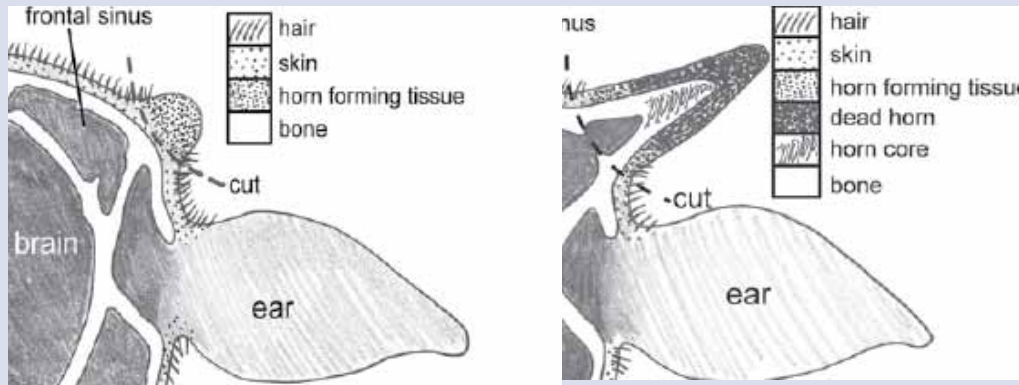

Figure 3.11. Young calf

Figure 3.12. Older weaner

## Branding

A fire-brand will provide permanent identification against loss or theft. Calves should be branded at between three and six months. A branding iron heated to a cherry red (red hot but not showing red in daylight) is applied to the calf's hide for three seconds.

## Castration

In some countries, entire males are preferred for traditional or religious reasons but castration is preferred in commercial animal production.

Beef bull calves can be castrated to:

- produce docile cattle that are easier to handle
- enhance on-farm safety for animals and workers
- prevent unwanted mating after puberty
- improve meat quality

Castration is best done as early as practical and definitely before the calf is six months old to minimise stress.

## Methods of castration

Bull calves can be castrated by either surgical removal of the testicles surgical or bloodless non-surgical methods.

## Surgical

Surgical removal is the most common procedure, but it is NOT bloodless and treatment is required to prevent screw worm fly strike, clostridial infections or tetanus.



About 1cm of skin around the base of the horn bud must be cut away to prevent the horn from regrowing.



*Holding calf for surgical castration. Restrain the calf, make sure both testes are down in the scrotum (purse), and remove them.*



*Application of elastrator ring over scrotum.*



## Elastrators

Elastration is a bloodless method of castration used at an early age. A tight rubber ring around the scrotum above the testicles shuts off the blood supply to the testicle and causes the scrotum to fall off 10–14 days later, or to be cut off after several days. The calf is restrained, the elastrator band is expanded, and placed both testicles, and then released.

However, there is still the danger of screw worm fly strike, clostridial infections or tetanus, while the elastrator band can break or a testicle retracted into the abdominal cavity may be missed.

## Creep feeding

Calves can also be fed additional more nutritious concentrate by using creep feeders which allow the calf, but not larger animals, access.

## Weaning

Calves for beef production can keep suckling for as long as the cow has good body condition as they will grow best while getting even a little milk. However, weaning is mainly for the benefit of the cow. If she keeps producing milk while on poor quality feed, she will lose too much weight and will not be able to get back into calf again. Most calves can be weaned at about six months of age.

### Early weaning

Where a cow is severely stressed and losing too much weight to produce milk for the calf, the calf should be weaned early and hand reared.

Weaning is stressful for any calf and it should be given good-quality feed to minimise any check in its growth. Weaners have to be held in a secure yard to prevent them rejoining their mothers, and should receive regular calm handling during this period.

After weaning, males and females (particularly replacement heifers) should be separated before they reach sexual maturity. A heifer needs to reach a mature weight above 275kg at 2 years of age before breeding.

### Vaccination

When six months old, calves should be vaccinated against relevant local infectious diseases (See Module 5. Animal Health and disease).

## Feet

Cattle that are mainly stall-fed without much walking or that live on wet soft ground develop hoof problems.

Wet weather and muddy ground can increase the incidence of lameness; sole injuries, infection of the skin around the hoof, and foot rot are more likely when wet conditions soften up the tissues and make them more vulnerable to bruising and injury (nicks and scrapes).

If infection sets in, the animal may need antibiotics and/or other medication to relieve pain. Pain caused by overgrown or misshapen hooves or severe hoof cracks sometimes requires feet trimming or surgery.

## Record keeping

The farmer should keep records of animal performance and treatments, of paddock treatment and grazing pressures. These help indicate farm productivity.

Good record keeping should include records of the following:

### Animal identification

Each animal should be given a number or name for easy identification. Permanent identification such as a brand, earmark or tattoo will help to prove ownership and resolve disputes over ownership. Any information should be recorded against that individual animal.

### Mating and calving

The date which each cow was mated, the number of times she has been mated before becoming pregnant and the bull that served her should be recorded. With artificial insemination (AI), the date and the bull should be recorded. This calendar will allow calculation of calving date. The date of calving, sex of calf and any problems should be recorded.

### Animal health

Record any veterinary assistance that may be given – who did it and when, what drugs or chemicals were used and why. (Refer Module 5, Animal health and disease)

A list of any drugs or chemicals along with their recommended 'use by date' and withholding period should also be maintained.

### Grazing

Where farmers are able to graze a number of paddocks or particular areas, knowing how many animals were in that area and for how long can help prevent overgrazing. The amount of pasture that is available for the cattle to eat should also be recorded. They should be moved out before all the pasture is eaten to leave enough groundcover and leaf for recovery.



*When cattle are kept on soft moist bedding in a pen and do not walk on hard surfaces, their hooves can grow long, and may need trimming.*

### Key points

- Records relating to animal health, reproduction and sales are essential.
- Records are useful to improve animal productivity and profitability.



## Feeding

When animals are kept in stalls, record what and how much they are being fed, when changes are made and why. Information on the source of feed allows quality to be challenged.

## Weighing

For accurate measurement of growth rates or sale weight, cattle have to be weighed on scales, but a weight tape will provide approximate weights.

How to measure beef cattle:

- Fast the animal off feed and water overnight (12 hours).
- Stand the animal with head in normal position and with the four legs set squarely under the body.
- Pass the tape tightly around the body just behind the shoulders at the smallest circumference.
- Record the girth circumference.

Tables 3.3 and 3.4 shows estimated live body weights of young and breeding cattle based on their girth measurement.

*Table 3.3. Estimating live body weight of calves and weaners by girth measurement*

Calves		Weaners	
Girth (cm)	Weight (kg)	Girth (cm)	Weight (kg)
74	36	100	101
79	42	110	127
84	51	120	155
86	56	130	188
91	68	140	223
94	74	150	262
97	80		

*Table 3.4. Estimating live body weight of breeding females by girth measurement*

Minimum for breeding heifers		Minimum for breeding lactating cows	
Girth (cm)	Weight (kg)	Girth (cm)	Weight (kg)
160	305	175	377
165	328	180	402
170	350	185	429
		190	457
		195	486
		200	515

## Marketing

Records of which animals were sent to which market and why, their estimated weight and the total price received should be kept. Knowing the cost of transport to market and any selling costs may allow the farmer to find a better overall deal.

## Appendix

### Making a rope halter

1. Obtain 4–5 metres of 10 or 12mm 3-strand rope.
2. Tie off end of the rope, (A) in Figure 3.13 to prevent un-ravelling or fraying.
3. Measure back 500mm from the tied off end.
4. Raise one strand of the rope at this point by holding the rope tightly in one hand and twisting the rope with the other as shown in Figure 3.14.
5. Run the short end of the rope through this raised strand until the loop opening is about 2.5cm in diameter, thus starting the loop splice (B) in Figure 7.1.
6. Complete this loop splice (B) by raising a strand of the short end where the ropes cross and run the long end through this raised strand. This loop splice (B) should be just large enough to allow the rope to pass through.
7. At a point 130–180mm from the whipped end (A), depending on the size of the animal, make three loops (one of each strand) close to each other by untwisting the rope and pushing it together. Figure 3.15.
8. Arrange these three loops in line with each other and parallel with the rope.
9. Run the long end of the rope through these three loops (D) toward the loop splice (B).
10. When the halter is adjusted to the proper animal head size, raise one strand of the rope that goes over the animal's head at (D) and run the whipped end through, thus holding the proper size.
11. Next make a crown knot (C) on the long end by un-laying the last 15cm of rope and alternately weaving each strand back into the rope several times. Dampen, roll and cut off any loose ends.

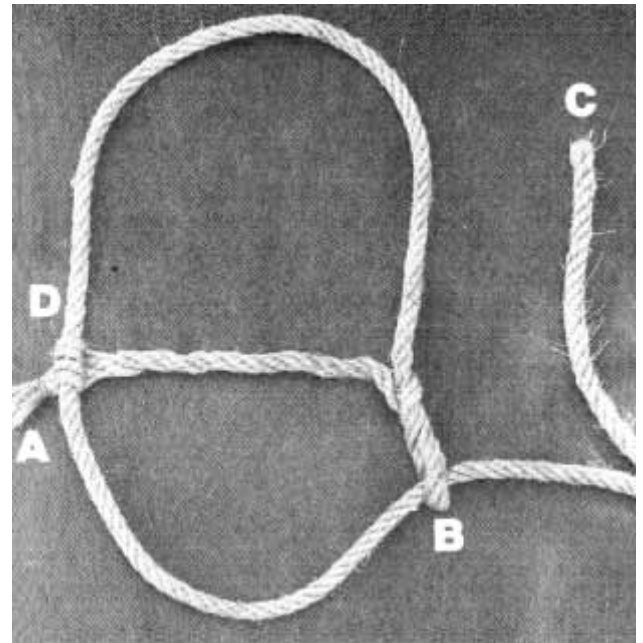

Figure 3.13

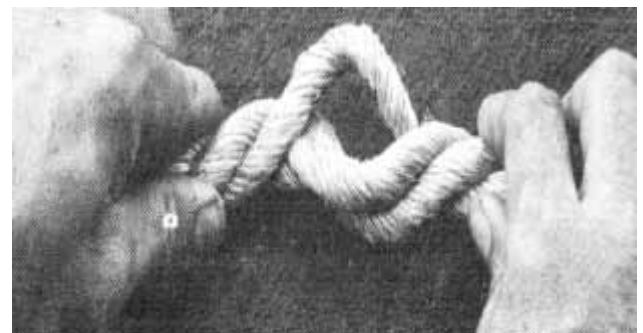

Figure 3.14

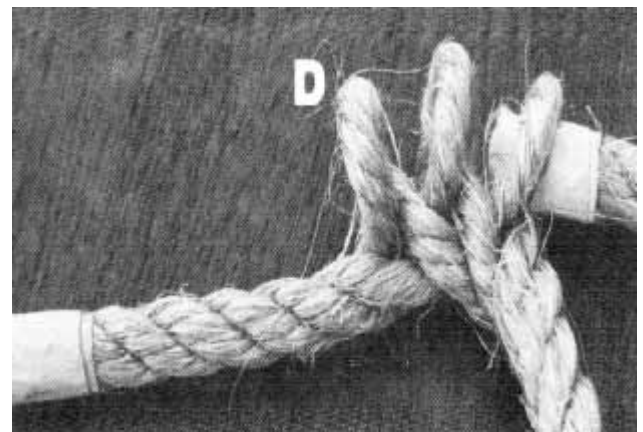

Figure 3.15



Level 1, 165 Walker Street, North Sydney NSW 2060  
Ph: +61 2 9463 9333 Fax: +61 2 9463 9393  
[www.mla.com.au](http://www.mla.com.au)



# Module 4

## Breeding beef cattle



Contact:

Meat & Livestock Australia  
Level 1, 165 Walker Street  
North Sydney NSW 2060  
Ph: 02 9463 9333 Fax: 02 9463 9393  
[www.mla.com.au](http://www.mla.com.au)

Published by Meat & Livestock Australia Ltd

ABN 39 081 678 364

June 2011

©Meat & Livestock Australia Ltd 2011

ISBN 9781741915792

Care is taken to ensure the accuracy of the information contained in this publication. However MLA and the contributors to this publication cannot accept responsibility for the accuracy or completeness of the information or opinions contained in the publication. You should make your own enquiries before making decisions concerning your interests. MLA accepts no liability for any losses incurred if you rely solely on this publication.

The inclusion of trade or company names in this publication does not imply endorsement of any product or company by MLA or any contributor to this publication. MLA and the contributors to this publication are not liable to you or any third party for any losses, costs or expenses resulting from any use or misuse of the information contained in this publication.

Meat & Livestock Australia acknowledges the matching funds provided by the Australian Government to support the research and development detailed in this publication.

Reproduction in whole or part of this publication is prohibited without prior consent and acknowledgement of Meat & Livestock Australia.

# Module 4

## Breeding beef cattle

This module outlines issues involved in breeding cattle in the tropics. It illustrates the sexual anatomies of male and female cattle and how suitable breeding stock should be selected. It describes signs of females being ready to mate, how they should be managed to maximise the production of calves and problems that may be experienced at and after calving.

### Contents

<b>Introduction</b>	2
<b>Selection of bulls</b>	2
Soundness for breeding	2
Physical characteristics of anatomy	3
Scrotum and testicles	4
Semen quality	5
Libido and temperament	5
<b>Selection of females</b>	6
Female reproductive organs	6
The udder	7
<b>Breeding management</b>	8
The breeding group	8
Feeding and breeding	8
Body Condition Score	9
Oestrus cycle (heat interval)	10
Detecting oestrus	10
For a calf each year	11
Bringing females to the bull	11
Mating after calving	12
Artificial insemination	12
Night mating	12
Detecting pregnancy	14
<b>Calving management</b>	15
Signs before calving	15
Abnormal calving	15
After calving	16
Retained placenta	16
Mastitis	17
Prolapse	17

## Introduction

Selecting the most suitable breeding stock will improve the herd and performance. The bull will have the largest influence because he could have 100 to 150 progeny in the three to six years of his productive life—or many more through artificial breeding—whereas the cow will have only six to eight calves.

Thus the most important selection should be for the bull; it should be objective and based on positive genetic differences and other factors associated with fertility.

## Selection of bulls

### Soundness for breeding

Mature bulls should be selected for the traits necessary to achieve the herd's breeding objectives.

They must have structurally sound legs, feet, joints and reproductive organs. The reproductive tract of the bull is shown in Figure 4.1.

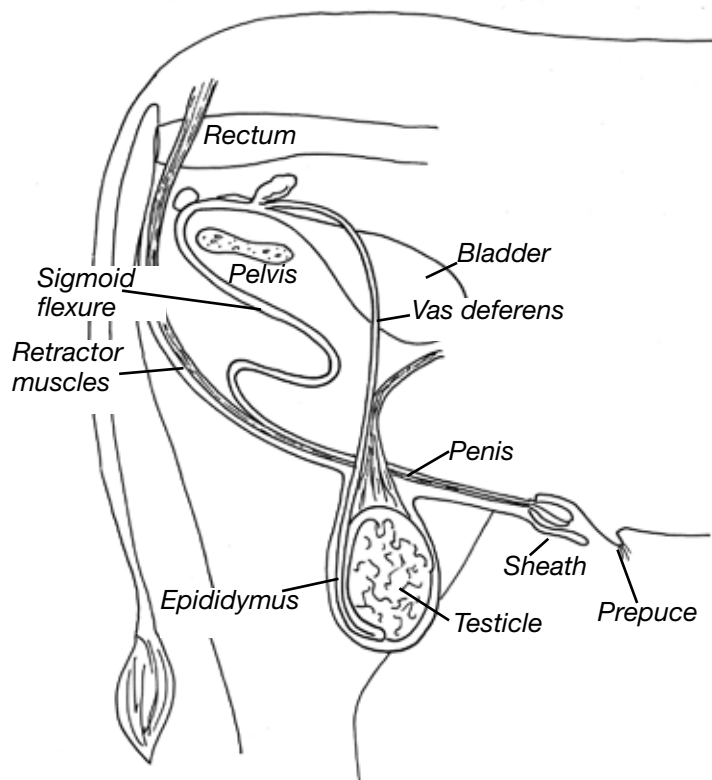

Figure 4.1. Reproductive organs of the bull

The bull must be fertile. The Bull Breeding Soundness Evaluation (BBSE) is a simple system that checks the factors that influence a bull's fertility. These include its physical soundness, scrotal circumference, semen quality, temperament and its keenness when placed with a female (libido).

To pass a BBSE, a bull must meet certain minimum criteria which are relatively easy to test and provide an acceptable set of standards for comparing bulls.

## Physical characteristics of anatomy

The sheath is the protective structure of skin surrounding the bull's prepuce and penis.

The ideal sheath:

- is light and loose
- is firmly and evenly attached to the underline for its whole length to achieve the desired angle
- does not have large areas of loose skin at the navel or around the sheath
- has no sign of protruding prepuce

Sheath score can be reported on a scale of 1 (very tight) to 5 (very pendulous).

*Bos indicus* bulls with a pendulous sheath are more prone to injure the prepuce.



*Sheath on a 2-year-old bull – well suspended, well angled, loose and light, and showing no tendency to be pendulous.  
Sheath score 2*



*A moderately acceptable sheath on a 3½-year-old bull.  
Sheath score 3*



*A fresh pink prepuce occasionally protruding is tolerable, but could prolapse.  
Sheath score 4*



*A very bad, permanent prolapse of the prepuce—which is dry and dirty.  
Sheath score 5*



Some bulls have 5–10cm of prepuce protruding below the end of the sheath. If the prepuce can be seen, the bull should retract this ‘pink mucosa’ when stimulated and it should not be continuously everted. Although such bulls often have a normal working life, they may have a prolapse in future. Anatomy of the sheath and prepuce is heritable, and bulls with large loose sheaths should be culled.

### Scrotum and testicles

Bulls with larger testes will produce more and better sperm, will produce daughters that reach puberty at a younger age, and these females will tend to be more fertile throughout life.

The testicles should be well-developed and properly balanced in relation to the age and size of the bull. Testes size (and scrotal circumference) is easy to select for and is highly heritable; physical scrotal size increases with age and better nutrition (Table 4.1).

The scrotum is measured by holding the neck of the scrotum with one hand, gently forcing the testicles into the bottom of the scrotum, then placing a measuring tape around the widest point of the scrotum.

The testes and epididymis should be palpated for size, tone, and symmetry and to make sure that there are no lesions on the epididymides. The testes should be firm but not too soft or too hard (Score of 3–4 on a 1–5 scale). A normal symmetrical testes shape is preferred, and any deviation in size, shape, and (or) position should be viewed with suspicion.

Common scrotal faults are:

- extremely pendulous, soft or swollen testes
- scrotum held in a tucked-up position
- ‘tied’ scrotum – where the attachment of the scrotum at the rear tends to hold it more horizontally to the body
- degenerative testes, penis and prepuce



Measuring bull's scrotum

Table 4.1. Minimum testicular circumference under different levels of nutrition

Age	<i>Bos taurus</i> and <i>Bos indicus</i> -derived bulls on moderate to good nutrition	<i>Bos indicus</i> bulls on moderate to good nutrition	Bulls on poor to marginal nutrition
12–15 months old	30cm	24cm	2cm less
18 months old	32cm	28cm	2cm less
≥ 2 year old	34cm	30cm	2cm less

## Semen quality

A semen sample should be examined for the percentage of normal spermatozoa; 50–70% normal is acceptable for multiple sire mating, and greater than 70% normal acceptable for single size mating and artificial breeding.

Semen can be collected by:

- rectal massage of the ampullae
- using an artificial vagina [AV] (as used when collecting semen for artificial breeding)
- aspiration of a sample from the vagina of a cow served by a bull
- using an electro-ejaculator

The electro-ejaculator is generally used to collect a semen sample from the bull restrained in a crush but requires a skilled operator. The electrical stimulation is gradually built up until the bull has an erection, and ejaculates a more consistent and larger volume sample (3–15ml) of semen and seminal fluid. However, some bulls do not respond well and some Brahman bulls go down with the stimulation.

Manual massage of the prostate, ampullae and seminal vesicles can also produce an ejaculate, and can be used on bulls that go down under electro-ejaculation. However, it often produces only a small volume of semen (several drops to 1ml) and this is frequently 'stale' semen awaiting excretion in the reproductive tract.

The semen must have greater than 30% individual motility and the sperm cell morphology must be greater than 50% normal (>70% normal for use in artificial breeding or as a single sire).

## Libido

The bull should also show he has an adequate libido or sex drive when with females.

## Temperament

Temperament is heritable. Culling bad tempered young bulls will result in easily handled cattle.

## Replacing bulls

The bull has a useful active reproductive life of only about eight years, after which his semen quality begins to drop. Bulls should be replaced sooner if they become injured or diseased.

## Selection of females



Good type of *Bos indicus* cow

The aim of a profitable beef enterprise is to produce a calf every year (365 days). Females must be selected for fertility and the ability to feed their calves. More-fertile females reach puberty at a younger age and produce more calves throughout life.

A healthy fertile female should show a broad chest and large well-sprung (curved) ribs, indicating adequate body capacity. They should be wide and long from hips to pins and deep from pins to the stifle joint, indicating that they will not have calving problems. The widest portion of the fertile cow should be in the midrib. A fertile female will have a level top line rather than a high tail-head. The udder should be strongly attached with a level floor and four neat teats without excessive swellings.

## Female reproductive organs

The ovary is the primary reproductive organ of the female. It produces:

- the female reproductive cell – the egg or ovum
- the hormones, oestrogen and progesterone

Each ovary is oval or bean-shaped 25–35mm long, located in the abdominal cavity. The secondary sex organs are, in effect, a series of tubes which receive the semen of the male, transport the sperm to the egg so it can be fertilised, nourish the fertilised egg (embryo), and expel the offspring. These organs include the vagina, cervix, uterus, uterine horns, and oviducts (also called Fallopian tubes) which have a funnel-shaped opening called the infundibulum (Figure 4.2).

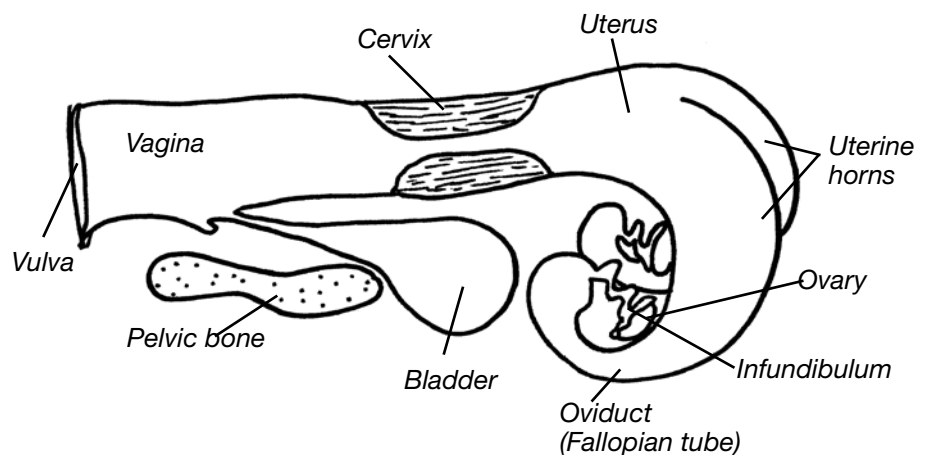

Figure 4.2. Reproductive organs of the cow

The ovary releases an egg on average every 21 days—the oestrus cycle. Hormonal changes occur with the enhanced release of oestrogen and these alter the cow's behaviour, making her ready and willing to conceive. She is commonly described as showing 'heat'. Detection of the oestrus cycle is described later.

## The udder

The cow's teats and udder must be of good shape. Culling cows with poor teats and udders improves overall calf performance, reduces calf sickness, increases longevity of the cow and reduces labour inputs.

Udder and teat conformation is moderately heritable so bulls should also be selected from those whose female offspring have good teat and udder conformation. Replacement heifers should also be selected from dams that have good teat and udder conformation.

A strong median suspensory ligament keeps the udder in good shape with teats pointing straight down when full of milk and well above the ground (Figures 4.3 and 4.4).

The ideal udder is tight to the body cavity and the four quarters should be level from the side and rear. Some udders will slope downward from front to rear, which is less than ideal, and rear udder attachment needs to be high.



*The ideal udder is tight to the body with all quarters even.*

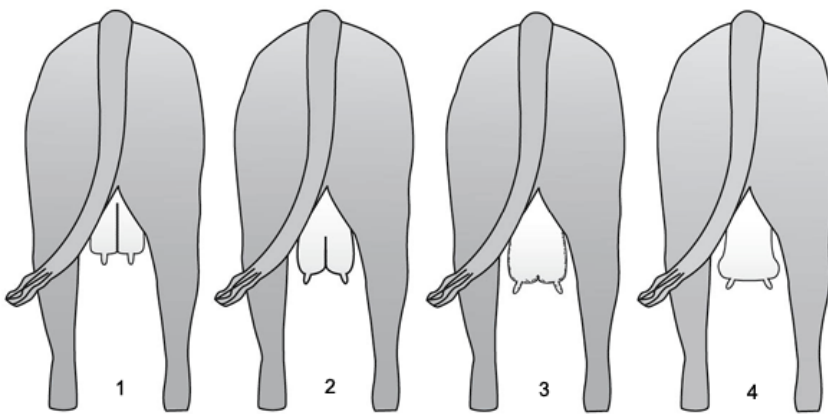

*Figure 4.3. Udder shape – 1 desirable with prominent median suspensory ligament holding udder tight to the body cavity and teats hanging vertically to 4 undesirable with no median suspensory ligament, udder and teats hanging below the hocks and teats splaying outwards.*



*A cow with a badly deformed udder should be culled as she will not rear a strong calf.*

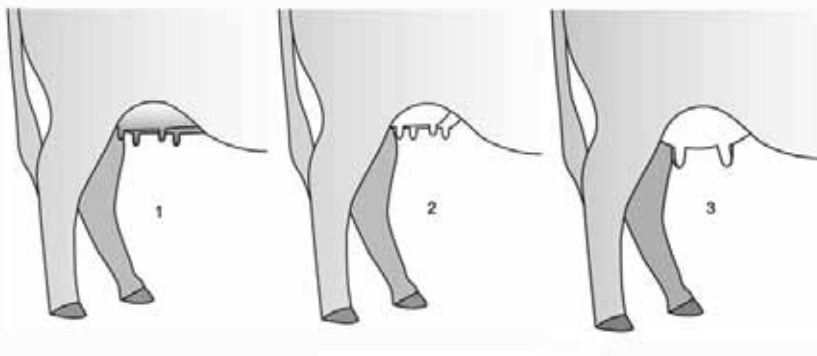

*Figure 4.4. Udder placement – side view*

## Breeding management

The purpose of cattle farming is to produce calves. The aim is a calf from every cow every year.

### The breeding group

A breeding group is a group of sexually mature females, of any age, ready to be mated to a bull. These may be from one owner or from a group of smallholders. Members of a breeding group need to live in the same village or neighbourhood so they can meet with the group leader for easy access to the bull, and to gain technical information from trained cooperative officers.

### Feeding and breeding

Nutrition has a major influence both male and female cattle fertility with good nutrition allowing the animals and their progeny to achieve their genetic potential.

An animal in poor body condition and with low weight is unlikely to produce a calf. If *Bos indicus* cows weigh less than 300kg, fewer than 15% will get in calf.

A body condition score (BCS) of 3–4 in females will increase pregnancy rates by up to 20%, with quicker re-conception after calving, but being too fat brings its own problems (Table 4.2).

Heifers that have not yet calved must be fed to maintain them with a body condition score (BCS) of 3–4.

At conception, the BCS of the lactating cow should be 2–3 but it must be raised to 3–4 at calving. This will allow her to produce more milk and become pregnant again.

Table 4.2. Effects of Body Condition Score (BCS)

Thin condition BCS 0–1	Fat condition BCS 4–5
• Will not cycle	• Wasted expensive feed
• Will not conceive	• Impaired mobility
• Longer intervals between calves	• May not cycle
• Increased days to oestrus	• May not conceive
• Weaker calf	• Difficult calving

### Oestrus cycle (Heat interval)

Farmers and members of a breeding group need to understand the oestrus cycle of their cows and to recognise the signs of heat.

The heifer's reproductive tract and secondary sex characteristics start to mature at puberty. Weight is more important than age; a well-fed heifer may reach puberty at between 5 and 11 months of age, a poorly-fed heifer much later.

Her reproductive tract increases in size, her udder develops and she starts an oestrus cycle.

### Feeding and breeding

“90% of the breeding is through the mouth.”

A poorly fed animal with high genetic potential will be less productive than a well-fed animal of lower genetic potential.

Good genes and good feed together give the best result.

### Key points

Non-lactating heifers with high Brahman content will begin cycling at about 285kg or above, while lactating cows with calves need to be a minimum of 350kg live weight.

Smaller local breeds will begin cycling at lower weights.

## Body condition scores



*Body condition score of 1*



*Body condition score of 2*



*Body condition score of slightly under 3*



*Body condition score of 4*



*Body condition score of about 5*

### Key points

Body condition scoring (BCS) is essential in any breeding program, and cattle should be evaluated regularly.

Cows should be monitored 100 days before they are due to calve and their body condition corrected.

Too thin cows have:

- trouble cycling and conceiving
- a higher chance of abortions
- longer intervals between calves
- less colostrum production and poorer calf immunity
- poor milk production and weaker calves

This oestrus cycle (heat interval) will normally continue at regular intervals until conception. The average interval between heat periods is 21 days, but may be between 18 and 24 days; it tends to be shorter in heifers than older cows and is shortened to around 15 days between the first and second oestrus after calving.

### Detecting oestrus and standing heat

Cows to be mated should be observed for oestrus in the morning and afternoon as a minimum, preferably more often.

Brahman cows often come into heat at night and the signs may be missed.

The most reliable sign that a cow is ready to be mated is that she will stand to be mounted by another cow—or the bull. This is called ‘standing heat’. Cows are in standing heat for only about 18 hours, less in hot weather and shorter in *Bos indicus* females than in *Bos taurus* females

#### Signs that a cow coming into heat (8 hours):

- restlessness and bellowing
- nudging and sniffing genital area of other cows
- wrinkling its nose and curling its lip
- swollen red vulva, frequent urination
- attempting to mount other cows but will not stand herself

#### Signs during standing heat (18 hours):

- early signs continue
- now stands to be mounted by another cow – for about seven seconds about four times per hour
- thin, clear mucus discharge from vulva
- mucus smeared over the pin-bones and tail area
- reduced appetite

#### Signs of coming out of heat (14+ hours)

- no longer stands to be ridden
- muddy flanks and ruffled tail head from being mounted
- dried mucus below vulva

The time to mate should be based only on standing heat.

Record these dates or mark the date on a calendar.

To help detect oestrus, tethered cows in the group should be brought together twice a day and allowed to move about as a herd with the bull before standing heat; all rope restraints should be removed or tied around the neck with no loose ends trailing.

‘Night mating’ refers to bringing all the non-pregnant heifers and cows inside a yard every night with the bull. This system works well with breeding groups.

As cows are more likely to have silent heats or shortened heats during the hot season, periods of continuously hot, humid weather can reduce conception rates.



Signs of coming into heat – swollen red vulva.



Signs of coming into heat – sniffing and curling lip.



Signs of heat: The cow is coming into heat when she rides another cow and is in standing heat when she allows others to ride her.

### Key points

The bull is the best detector of oestrus.

Running the bull with the herd increases his libido and stimulates the heifers and cows.

## For a calf each year

The average gestation period for *Bos indicus* cows is 290 days. To produce a calf every year means that they have to become pregnant again within 75 days of calving.

The breeding organs return to normal condition about 36 days after calving so only 40 days, or 2 oestrus cycles, are available if the cow is to have that calf every year.

Cows that calve in condition score 4 and are well fed can go back into calf on the first or second oestrus cycle.

Cows in poor condition and further stressed by lactation may stop cycling—lactation anoestrus—and so cannot conceive. These cows will need extra good-quality feed, or for the calf to be weaned before they will come into oestrus again.

Heifers should be well grown at between 280 and 300kg at first breeding to minimise the chances of difficult calving.

## Bringing females to the bull

To produce a calf, the cow must first be mated. The breeding group needs to be organised so that each cow or heifer can be brought to the bull at any time during the breeding season. Maiden heifers need to be exposed to the bull for a shorter period (fewer heat cycles) as they will generally conceive quicker than the mature cows with calves at foot. Heifers can be mated for at least six weeks and most cows for three to four months.

Preferably the cow should be with the bull before her standing heat, but she must be taken to the bull immediately standing heat is seen, or inseminated within 12 hours of standing heat. After 14 hours, it is too late to take the cow to the bull as she will not stand to be mounted. The bull may try to mount, but the cow not let him.

If the breeding yard is centrally located, females can be brought to the bull when standing heat is first observed and then 18–21 days later. As cows come on heat at approximately 21 day intervals, the repeat mating allows the bull to detect heat and the farmer to correctly time the earlier mating.

When standing heat is observed, avoid stressing the female when bringing her to the bull.

Exposing the heifer to the bull during the pre-oestrus period will raise the libido of both animals and help achieve a successful conception.

The heifer should be with the bull throughout the period of 'standing heat', which will last for about 18 hours. In practice, this may mean having her in the yard with the bull over a period for up to 5–6 nights.

An example breeding calendar for good management of the cow is shown in Figure 4.5.

## Repeat mating

Re-mate all heifers and cows 18 days after last standing heat, and leave them with the bull for five days.



*Signs of standing heat – clear mucus discharge.*

## Silent heat

Silent heat occurs when the cow ovulates but shows little or no sign of heat.

It is more prevalent within the first 50 days of calving and occurs prior to the first visible heat.

Many so-called silent heat periods are simply missed heats due to more detection techniques.

## When to mate

When to mate should be based only on standing heat.

While other changes may be seen during the start of her heat period, the only sure sign of when to mate her is standing heat.



## Mating after calving

To produce a calf every year, the cow must get pregnant within 75 days after calving.

The first heat should come 30–72 days after calving, and although the cow should be mated then, conception rates tend to be lower than with later heats. Re-mate the cow on the second heat period after which the uterus should have returned to normal.

If the cow does not get sufficient feed and is in poor condition with a BCS of two or less, she may not have a second oestrus cycle; she must be fed well to achieve body weights greater than 350kg if suckling a calf.

After mating, record the date. Observe her for heat signs 18 to 24 days later and again 18 to 24 days after that. If she misses two heat periods, you can usually assume she is pregnant; but she might have a reproductive disease.

Figure 4.5. A typical breeding calendar

Month											
1	2	3	4	5	6	7	8	9	10	11	12
Breeding /joining											
			Joining: 1 <sup>st</sup> trimester; monitor BCS								
					2 <sup>nd</sup> trimester Monitor BCS						
						3 <sup>rd</sup> trimester; calving					
									Monitor progress and BCS		

## Artificial insemination

Breeding through artificial insemination (AI) offers access to better sires and a wider range of genetics than the ‘local village bull’.

An experienced AI technician will visit the village and the ‘farm’ to inseminate the cows that have been identified as ‘on-heat’. The farmer identifies these females using the signs described, holds them in a secure yard for insemination 6 to 12 hours after first detection of signs of ‘heat’.

After insemination, the female should be held in the yard away from the herd bull (and any local bulls) for about 48 hours. If the cow returns to oestrus about 21 days later, she can be inseminated again or mated to a ‘local’ bull as part of the natural mating program. Pregnancy can be tested as normal.

## Night mating

*Bos indicus* cows and heifers often do not show signs of heat or mate during the day. Grazing the herds during the day on



Ready reckoner that calculates date of calving from date of conception.

communal pasture areas with access to a bull, but then yarding them at night away from the bull greatly reduces the chance of conception.

Calving rates are much improved if the bull remains with the empty cows and heifers in a communal yard each night.

### Advantages of night-mating yard

A night-mating yard can:

- solve the problem of heat detection and silent heat in animals
- stimulate the sexual drive of the animals—particularly the bull.
- shorten the calving interval by earlier mating
- detect difficult breeders and barren animals more quickly

### Schedule of night-mating

If feeding the heifer in the night yard is a problem for an individual farmer, the animal can be removed after the bull has been seen effectively mating and then returned to the night yard 15 days later for 10 more days.

If she fails to come on heat for the second service, she is probably in calf. If there is still doubt, she can be returned to the night yard a third time. If she has not got into calf from three matings, she may well have a reproductive disorder.

### Preparing a night-mating yard

- The community or breeding co-operative must agree to construct a yard on a well-drained area that is accessible to most of the members. The yard must be secure and provide clean water and roughage (and preferably have lighting).
- The bull must be in good body condition, fertile and without any sexually transmissible diseases.
- Empty heifers and cows must also be in good body condition with a minimum condition score of 2–3 to ensure that the animals are cycling.

Table 4.3. Night-mating schedule

Nights	Actions
1–45	<p>Every night bring all non-pregnant heifers and cows inside the yard together with the bull.</p> <p>To avoid feeding problems during the program, advise every owner to feed his own animals.</p> <p><b><i>The bull and females should be well fed with quality feed during this period.</i></b></p>
46–60	<p>Rest and feed the bull to ensure he is in top condition before re-mating.</p>
61–90	<p>Provides females that failed to conceive at the first mating another chance.</p> <p>The bull and females should be well fed with sufficient quality feed during this period.</p>
Total 90 nights	<p>A total of 75 nights allows a minimum of three oestrus cycles with the bull.</p>

## Mating without a night-mating yard

### Mating

- Cows seen coming into heat should be brought to the bull immediately. The bull is allowed to mount her more than once, and they are left together for 2–3 days. The days when she is seen standing to the bull are recorded. Loss of hair on pin bones and mud on her flanks the next morning can indicate that mating occurred at night.
- Stress during mating can affect conception. To avoid unnecessary handling at this time, it is better to have the heifer with the bull before standing heat. This is possible if the date of the last heat period is recorded, and the heifer is returned to the bull 15 days later.



Above and below. Crushes of varying strength for holding the cow for AI.



## Detecting pregnancy

Pregnancy can be detected (Pregnancy Diagnosis or PD) by a trained AI technician or a veterinarian by rectal palpation (Figure 4.6). Pregnancy can be diagnosed three months after conception but is more definitive later. Breeding records help to confirm the pregnancy, and also estimate the calving date.

The cow must be able to be secured well during a PD in order to minimise risk of injury to the technician and the cow.

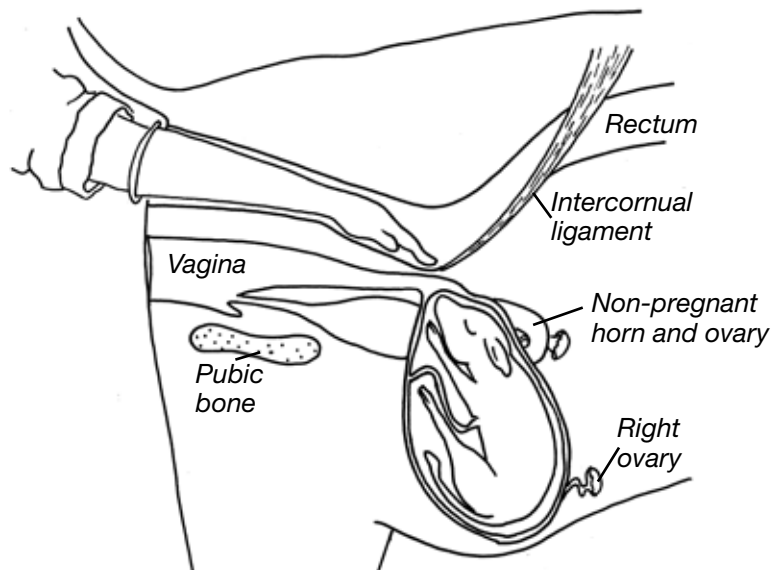

Figure 4.6. Rectal pregnancy detection



A simple mating crush to restrain the cow for the bull.

## Calving management

### Signs before calving

*Bos indicus* females calve 290 days (285–295) after conception. At about 7–8 months, the udder of the cow starts to fill. As calving approaches the teats become distended and full. At 7–10 days before calving, the vulva expands, and may change in colour. The swollen vulva often discharges mucus.

The cow should be bedded down on clean straw in her stall where she should be disturbed as little as possible. In their natural condition, *Bos indicus* cattle calve easily.

When she starts to calve, she will arch her back and strain. She will lose two lots of water with the second thicker than the first. Within two hours of the cow losing her second water bag, the calf's two front legs should appear if the birth is proceeding normally; the cow should not be disturbed but allowed to calve naturally. Look at the cow about every 30 minutes during the calving, but leave her alone if the calf is coming out. Only interfere if there is no progress.



A cow two hours before calving. Notice the mucus coming from the vagina, which has become loose, and the swollen udder.

### Abnormal calving

Most cows calve without trouble. If calving is not proceeding normally, and is extended beyond 4–6 hours, seek veterinary assistance.

If the cervix is fully dilated and three essential parts of the calf (two forefeet and head or two hindfeet and tail) can be felt in proper position, the problem may be due to the uterus not contracting properly. Attempts can then be made to pull the calf out. However, prolonged calving can cause the uterus to tire and stop contracting; then there is the danger of the uterus rupturing.

Some abnormal calving presentations are shown in Figures 4.7b and 4.7c.

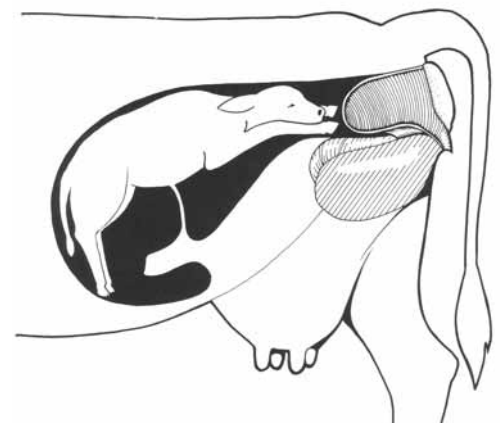

Figure 4.7a. Normal position of calf

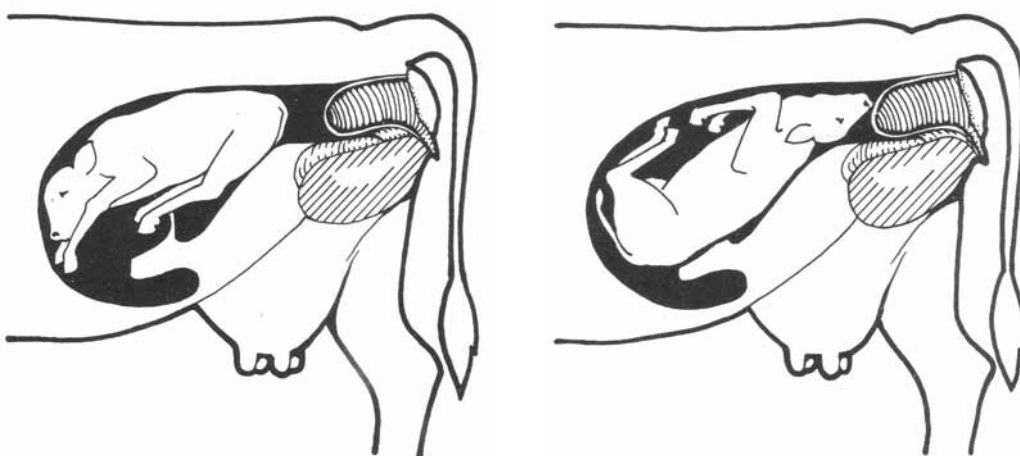

Figure 4.7b and 4.7c. Problems at calving. Left – Breech presentation (hind legs forward) Carefully push the calf forward and bring the hind legs into the birth canal. Right – turned calf. Turn the calf over and bring the front legs forward.

If the calf is dead, it will feel dry with no movement and it will probably be rotten. The dead calf swells after 12–24 hours and becomes almost impossible to pull out. Veterinarian assistance will be needed to remove the dead calf or the cow may become infertile or die.

Once the calf has been born, allow the mother to clean her calf up. If the mother is too weak, the calf should be cleaned up by the farmer. Mucus may have to be cleaned from the nostrils and attempts made to start the calf breathing.



Allow the calf to suckle the colostrum to provide immunity.

### Key points

Once the calf is born, leave the cow to clean it, and to establish the bond between cow and calf.

Cows must be carefully monitored during calving and for the next two weeks to detect any problems, and then to give help.

A clean calving area will reduce the risk of disease or bacterial infection.

The calf must be allowed to get adequate colostrum over the first three days.

### After calving

The cow will lick the calf clean and allow it to suckle. This establishes the early bond between cow and calf.

Avoid handling the calf for the first 12–24 hours while the mother is recovering from calving. If the farmer handles the calf before the mother, his smell will be transferred to the calf and a *Bos indicus* cow may disown the calf.

The calf must be allowed to suckle adequate colostrum over the first 2–3 days as this will provide immunity.

*Bos indicus* cows are the best mothers of any breed but are very protective of their calves and can become aggressive against interference.

### Placenta ('Afterbirth')

When the calf is born, the placenta normally detaches within a few hours and is expelled within 12 hours. If it is not expelled by 24 hours, it is defined as a retained placenta or the cow is said to "have not cleaned".

If the placenta does not come away naturally, it should be left alone, and not pulled out. Pulling the afterbirth with force can cause a haemorrhage and the cow could bleed to death. Check 12–24 hours later and, if necessary, leave for another day and then seek veterinary assistance.

A retained placenta usually increases the time from calving to the next conception; a cow with a retained placenta may well delay the next pregnancy for 2–6 months.

If the calf is born dead, clean the cow up immediately if possible. If the cow is sick, give antibiotics for 3 days and an intrauterine bolus (Terramycin) or an intrauterine infusion.



A retained placenta after giving birth

## Mastitis

**Mastitis** is an infection of the mammary glands that becomes a major issue where many cows are penned together.

Mastitis causes the teat to swell painfully while the infected milk becomes a thick creamy fluid that the calf cannot suck out.

The risk of mastitis can be reduced by:

- feeding adequate minerals in the diet, particularly calcium and selenium
- cleaning out of the pens between re-stocking
- separating cows with signs of mastitis from the herd

Mastitis may be harder to detect and to treat in grazing beef herds than in dairy herds that are handled every day.

The hind legs of the cow may have to be roped together to prevent the cow from kicking when the tender udder is touched to strip the milk out of the affected quarters.

Treatment is by injecting the entire content of a tube of antibiotic directly into the teat canal. Seek help from your vet as to the best antibiotic to use.



*A swollen and inflamed udder with mastitis*

## Prolapse

Prolapses can be of the vagina and cervix or of the uterus.

### Causes of prolapses

- Cows with relaxed sacral ligaments and those straining tend to have increased risk of prolapse.
- Frequently occurs in cattle transported in the third trimester of pregnancy, and in those that are kept tied up and given little exercise.
- More likely if a cow heavy in calf stands with hindquarters lower than forequarters.
- Almost always occurs at calving or soon after calving when the cervix and uterus are open and lack muscle tone.

### Treatment

In prolapse of the vagina after calving, the animal generally recovers and no further problems occur. If the uterus prolapses, seek veterinary assistance. While waiting for assistance, the farmer can:

- If possible get the animal to stand.
- Wash the prolapsed organs with clean water and disinfectant with a slightly salty solution.
- After cleaning the prolapsed organs, apply gentle pressure and begin to push them back in place. Additional support can be given by sutures in the vulva or a slight tourniquet around the prolapsed reproductive tract
- If this is difficult, try to stretch the hind legs out behind animal, or stand the female on an incline with hind legs on the high side of the incline.
- Treat with a long-acting antibiotic to avoid infection.



*Prolapsed uterus*



Level 1, 165 Walker Street, North Sydney NSW 2060  
Ph: +61 2 9463 9333 Fax: +61 2 9463 9393  
[www.mla.com.au](http://www.mla.com.au)



# Module 5

## Animal health and disease





Contact:

Meat & Livestock Australia  
Level 1, 165 Walker Street  
North Sydney NSW 2060  
Ph: 02 9463 9333 Fax: 02 9463 9393  
[www.mla.com.au](http://www.mla.com.au)

Published by Meat & Livestock Australia Ltd

ABN 39 081 678 364

June 2011

©Meat & Livestock Australia Ltd 2011

ISBN 9781741915792

Care is taken to ensure the accuracy of the information contained in this publication. However MLA and the contributors to this publication cannot accept responsibility for the accuracy or completeness of the information or opinions contained in the publication. You should make your own enquiries before making decisions concerning your interests. MLA accepts no liability for any losses incurred if you rely solely on this publication.

The inclusion of trade or company names in this publication does not imply endorsement of any product or company by MLA or any contributor to this publication. MLA and the contributors to this publication are not liable to you or any third party for any losses, costs or expenses resulting from any use or misuse of the information contained in this publication.

Meat & Livestock Australia acknowledges the matching funds provided by the Australian Government to support the research and development detailed in this publication.

Reproduction in whole or part of this publication is prohibited without prior consent and acknowledgement of Meat & Livestock Australia.

# Module 5

## Animal health and disease

This module describes how farmers and cattle handlers need to observe their stock daily so as to identify and treat suspect animals promptly.

It describes a number of common parasites and diseases and their treatment or prevention.

### Contents

<b>Observational skills</b>	2
Recognising sick animals	2
Healthy animal behaviour	2
<b>Animal health management</b>	3
Administering vaccines	3
Rumen function and nutritional stress	4
<b>External parasites</b>	4
Cattle tick	4
Screw worm fly	5
Buffalo fly	5
Ringworm	6
<b>Internal parasites – ‘worms’</b>	6
Round worms	7
<b>Diseases affecting reproduction</b>	8
Leptospirosis	8
Brucellosis	8
Vibriosis	8
Infectious Bovine Rhinotracheitis (IBR)	9
<b>Clostridial diseases</b>	10
Blackleg	10
Tetanus	10
Botulism	11
<b>Other important diseases</b>	11
Footrot	11
Anthrax	12
Foot and Mouth Disease	12
Hemorrhagic septicaemia (HS)	12
Bovine tuberculosis	13
Johne’s Disease	13
Ephemeral fever	14
Scours and diarrhoea	14

## Introduction

Animals must be healthy for a profitable business. Diseases and parasites must be eliminated or kept at a level that does not impact on their overall health, reduce their growth rate, or their ability to produce calves.

The farmer or manager need to develop good observational skills to check behaviour and identify a sick animal.

## Recognising sick animals

Some of the common signs that animals are not well are that they are disinterested in what is happening around them, they stand alone with their heads down away from other animals, or are seen lying down a lot. Other indicators are sunken eyes, rough coat or a stiffness or lameness when trying to walk.

## Healthy animal behaviour

Farmers and those who work with cattle should know how a normal healthy animal behaves, and check their animals each day.

Signs to look for include:

- **General behaviour** – Are all animals behaving normally or are some animals standing on their own with their heads down?
- **Resting** – Are the animals resting and ruminating (chewing their cud)?
- **Eating** – Is the animal eating? Is the problem the animal or the feed?
- **Breathing** – Is the animal breathing normally or too quickly or too heavily? Is this caused by heat stress, fever, disease or an internal infection?
- **Drinking** – Do they look dehydrated (eyes appear sunken, the coat is dry and dull) or keep standing around the water trough? Is there some problem with water quality?
- **Manure** – Is the dung watery or too hard? Is this caused by nutritional imbalance or by disease?
- **Discharges** – Are there discharges from the eyes, mouth, nose, vagina or anus?
- **Injuries** – Is an animal lame? Does it have a wound? Is the wound infected?
- **Temperature** – Does the animal have a high body temperature (above 38.6°C)?

Some low-level problems take time to show up as slower growth rates, tired looking animals or long calving intervals.

## Reading manure

Signs of disease and ill health can often be seen in the dung of cattle. Healthy dung pats are well-formed, green in colour and do not have an offensive odour.



*Recognise the signs of a sick or malnourished animal.*



*Dry and mounded dung may indicate poor feed or low protein.*

Dung that is hard, dry, in balls, or mounded in a heap indicates that the feed is high in fibre and low in protein.

Very watery dung indicates a digestive upset or diarrhoea. No dung indicates the rumen is not functioning well.

## Animal health management

The farmer should know what diseases and parasites are normally present in his area, in which seasons these are more likely to occur, their symptoms and treatments. Information on their symptoms and treatment should be available locally.

Symptoms of disease may not be immediately obvious and may be confusing. Experience and local knowledge will generally result in the correct diagnosis but some diseases have the same symptoms and need to be diagnosed by a trained person.

Once abnormal behaviour is seen, the cause must be identified and the correct treatment given as soon as possible.

Good animal health is best achieved by preventing animals from contracting diseases and avoiding the infestation of parasites. Prevention is much cheaper than the cost of treatment and the loss of productivity.

Prevention is helped by ensuring that all animals have access to enough good feed and clean drinking water. Giving feed in clean troughs and off the ground will greatly reduce the spread of intestinal worms. A system of moving animals to rested pasture will help minimise the spread of diseases and parasites, particularly worms and ticks.

### Key points

Early detection of any symptoms allows earlier treatment and cure.

Undetected and untreated diseases or parasites will affect the long-term health of the livestock and farmers' prosperity.

Prevention is better than treatment.

## Administering vaccines

When vaccinations, antibiotics and other chemicals are used, the instructions and schedules must be followed. Keep vaccines under cool storage and read the label, and always administer the vaccine as directed by the manufacturer.

All injections are best given when the animal is restrained in a crush or on the ground. As some vaccinations may cause localised scarring or form abscesses under the skin at the injection site, all intra-muscular and subcutaneous injections should be administered forward of the shoulder in the neck. This is the least commercially valuable site and the loss of meat at slaughter is minimised.

Do not inject cattle in the top of the rump or back of the leg.



Sloppy dung with bubbles may indicate acidosis.

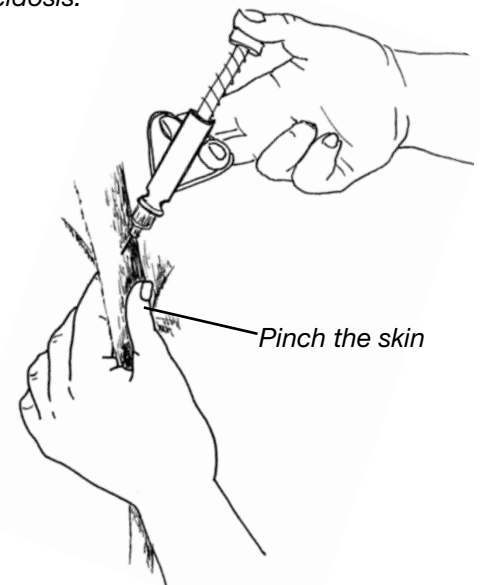

Subcutaneous vaccination. Pinch the skin so that the needle does not penetrate the muscle.

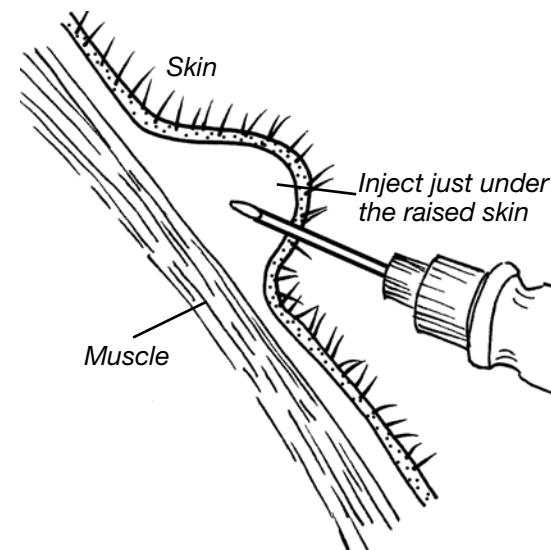

## Rumen function and nutritional stress

Maintaining normal rumen function is the key to avoiding nutrition stress. The animal needs to eat enough good-quality grass or feed and drink enough water to ensure a good balance of fibre and fluid for fermentation in the rumen. (See Module 2 Nutrition)

Nutritional stress occurs when the animal is not getting enough feed and water or they are of poor quality. It cannot extract enough nutrients if fed too much roughage (low-quality forage, grass or straw) or too wet feed (wet pineapple waste).

One of the first signs of nutritional stress is that an animal begins to lose weight. If female, it will then not cycle and will not get back into calf.

A sign of a lack of feed is animals standing around the feed trough, and maybe licking the walls of the empty trough. With poor quality feed, they will often eat the leaf first, leaving the poor quality roughage or stalk till last.

Similarly with lack of water, the cattle will wait around the water trough when they should be out eating grass or resting and chewing their cud.



*Cattle ticks are generally first seen on the brisket and underline of animal. European breeds and their crosses are most susceptible.*

## External parasites

External parasites are generally blood-sucking insects such ticks, buffalo fly and lice. Some can spread blood-borne diseases, or cause irritation or skin infections. In the case of screw worm; fly maggots eat the flesh in open wounds.

### Cattle tick

*Bos indicus* cattle are mainly resistant to ticks but can become infested when in poor condition. European breeds and their high grade crosses are the most susceptible. Grazing animals are more likely to be infested than penned animals.

Cattle ticks can be controlled by a combination of chemical treatment of the animal and rotational grazing of paddocks. The tickicide will reduce the numbers of ticks present while not grazing the same pasture area for another four weeks after treatment will break the tick breeding lifecycle. The baby ticks ('seed ticks') on the grass will die if there are no cattle for them to feed on.

Chemical treatment by itself is effective, but more expensive than when combined with rotational grazing. However, chemical treatment will be the only option for farmers who do not own their own grazing land and cannot control grazing.

Tickicides can be applied by spraying or being poured along the animal's back. Some tickicides also kill lice. Always read the label of the product carefully to determine the correct method of treatment.



*Insecticidal pour-on is easy to apply, and will last for up to three weeks for both internal and external parasites.*

### Key point

Chemicals should not be applied to wet animals or if rainfall is expected lest they be washed off or too diluted to be effective.

### Buffalo fly (*Haematobia irritans exigua*)

The buffalo fly is a small (3.5–4 mm) biting insect that irritates cattle, interrupting feeding and causing sores. In the wet tropics, buffalo fly can reduce beef cattle production by up to 16%. Sores from buffalo fly infestations can result in permanent damage to hides.

Dark-coated cattle, bulls, older cattle and those in poor condition usually attract the heaviest infestations of fly. *Bos indicus* cattle can carry high numbers of flies but do not appear to be as severely affected as other breeds.

Buffalo fly should be treated as soon as they are seen to prevent populations building up and causing severe irritation and loss of condition.

Specific chemicals can be sprayed onto the cattle or mixed with oil and placed in a padded bag that the cattle can rub up against. Ear tags can release a chemical repellent.

### Screw worm fly (*Haematobia irritans exigue*)

Screw worm flies (SWF) breed in wounds on mammals, including humans and cattle. The female SWF lays up to 250 eggs on the edge of an injury such as a scratch, branding mark or castration wound or the navel of new-born calves. Larvae (maggots) hatch within 24 hours, enter the wound and chew their way into the healthy underlying flesh to feed. The wound becomes a mass of maggots, causing extensive tissue damage and leaving the flesh susceptible to a secondary fly strike and infection. After about a week, the larvae drop from the wound to pupate in the soil. Adults emerge in another seven days to mate and repeat the cycle.

#### Symptoms

SWF strikes may occur at any site on the body. In a heavily infested herd, 10–15% of animals may be struck at any one time. Mortality rate in new-born calves from navel strike may be as high as 30–50%.

Signs include:

- ragged, foul-smelling wounds containing SWF maggots
- constant licking of the wound by the animal
- fever
- poor growth rate or weight loss

#### Prevention and treatment

SWF strikes must be detected early; if treatment is delayed, severe infestations can result in death.

SWF are highly susceptible to a range of insecticides. While their use against adult SWF is largely pointless, their use against larvae (eg in wound dressings) is an essential element of prevention and treatment. Ivermectin is particularly effective at dosages of 1 mL/50kg liveweight as a subcutaneous injection to prevent infection of SWF in cattle. Spraying or dipping livestock with coumaphos (0.25% aqueous suspension of 50% wettable powder) can be used for prevention. Calves are often struck on the navel, and can be caught and treated.



*Lesion caused by buffalo fly.*



*Back rubber soaked with oil and appropriate insecticide for control of buffalo fly.*



*Screw worm fly.*



*Screw worm maggots in wound.*



*Insecticidal ear tags are easy to apply, and provide slow-release insecticide for up to four months.*

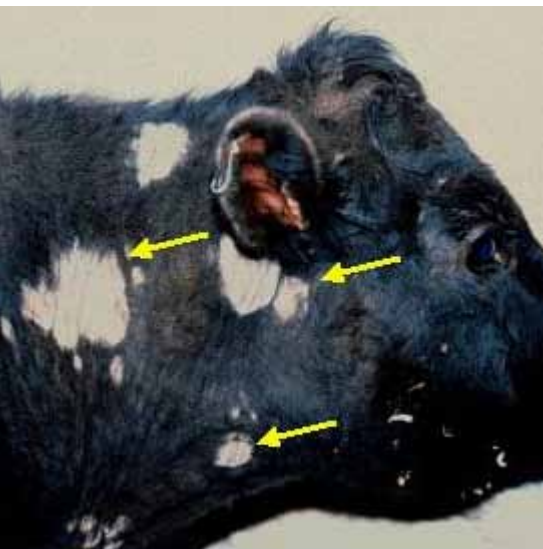

*Cattle usually recover spontaneously from the highly infectious ringworm fungus.*

The infected wound should be cleaned of maggots and the insecticide applied to kill and prevent re infestation. Remove maggots from the damaged tissue with surgical forceps or pincers, and apply powdered sulphanilamide to clean up the infection. Apply parasiticides and mix in Vaseline so that the insecticidal value will last, but always use it according to the manufacturer's directions. The use of Ectomectim will kill all larvae and give 56 days protection against re-infestation, providing the wound with time to heal.

Good livestock husbandry practices to minimise the risk of injury and open wounds help to prevent SWF strike.

The farmer should contact their local government agent for the latest information on the best way to control these parasites or seek veterinary advice.

### **Ringworm**

Ringworm is a highly infectious fungal disease, mainly seen in young animals. The fungus infects the outer layers of the skin and the hair follicles causing skin thickening and hair loss.

It does not affect growth or reproduction, and almost all cattle make a full recovery spontaneously in about eight weeks, leaving no permanent mark.

#### **Symptoms**

Ringworm is seen as circular grey-white crusted lesions about 3cm in diameter mainly on the head and neck. The lesions often join to form larger areas of thickened, hairless skin and, in severe cases, can be found all over the body.

#### **Treatment**

As cattle recover spontaneously, ringworm is not usually treated. The affected areas can be scrubbed with soap and water and then bathed with a 1% solution of tincture of iodine for 3 to 7 days. Cattle can also be sprayed with iodine solution or with the antifungal drug Natamycin to slow the spread of the fungus. However, it still takes time for the hair to grow back. Infected cattle can be segregated to reduce the spread of the disease.

Note that ringworm can infect humans.

### **Internal parasites –‘worms’**

These parasites can generally be grouped as round worms or as flat worms. Some worms spend their entire life cycle in the cattle, others spend a part of their life cycle in other hosts. Parasitic roundworms, or nematodes, are found in cattle in most parts of the world.

Most internal parasites are spread as cattle deposit the eggs on the ground in their dung. The eggs then hatch and contaminate the pasture or feed. In some worm types, the eggs are eaten and then hatch inside the animal, but most worm eggs hatch on the pasture. This pasture is eaten by the cattle foraging for food. Feed harvested for cattle should be fed in a trough off the ground to reduce the spread of worms through contamination with dung.

## Symptoms

Symptoms may not become evident until the worm infestations become heavy. Signs to look for include:

- poor or skinny animals, or loss of weight
- rough or dry coat
- diarrhoea, which may be foul smelling
- ‘Bottle jaw’ – swelling under the jaw caused by fluid build-up
- eggs in the dung
- death (in acute cases)

## Treatment

Treatment for internal parasites is generally by drenching with chemicals or by pouring a chemical along the back of the animals. Insecticidal pour-on is easy to apply and will last for up to three weeks for both internal and external parasites. But the type and degree of the parasitic burden should be identified for a correct treatment.

Read the product label for instructions on when and how to use the product and the recommended dose rate, and for warnings on when not to use it, such as on lactating cows, and the recommended methods of storage and disposal, and an expiry date.

## Roundworms

Parasitic roundworms, or nematodes, are found year-round in cattle in most areas of the world. These parasites live in many sites with each occupied by specific roundworms. Sites include lungs, gastro-intestinal tract, body cavity and beneath the skin.

As there are usually just a few of these roundworms present, the harm they cause is not always apparent and can be difficult to assess.

### Treatment and control

Have the problem worm species identified from dung samples.

Use anthelmintic pour-ons or drenches. Spelling grazing areas to break the life cycle of the worm.

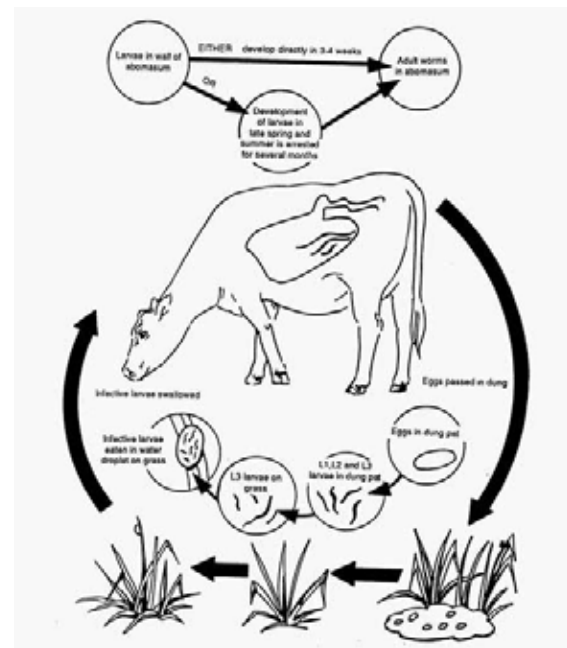

*Cattle eat worm larvae on grass during the cycle of gastro-intestinal roundworms.*

## Key points

- Correct diagnosis and early treatment is important
- Young animals and animals in poor condition or health are the most vulnerable to parasites or diseases as their natural immune system is functioning effectively.



## Diseases affecting reproduction

Diseases that can affect reproduction include: Leptospirosis; Vibriosis; Brucellosis; and Infectious Bovine Rhinotracheitis (IBR)

### Leptospirosis

Leptospirosis is a spirochete that is often found in wetlands, waterholes or rivers. It is commonly spread by infected animals passing the Lepto organism in their urine onto pasture and drinking water. It is transmissible from animals to humans.

#### Symptoms

Affected calves will exhibit a yellowish discoloration of the visible mucous membranes coupled with blood-tinged urine, a loss of appetite, and maybe fever and anaemia. Symptoms in older cattle vary greatly making diagnosis difficult. Abortion is common and milk production drops sharply. The milk may be thick, yellow and blood-tinged, without any sign of udder inflammation.

#### Treatment

The disease can be prevented by vaccination.

### Brucellosis

Brucellosis is a contagious bacterial disease that can cause abortion.

#### Symptoms

Pregnant females will abort a foetus at about 3–6 months after conception. Infected animals spread the disease through the urine or an aborted foetus onto pasture or in the drinking water. Infected animals should be culled to prevent the spread of the disease.

#### Treatment

Currently there is no cure for brucellosis. For prevention, heifer calves can be vaccinated at between 6 and 8 months; to control the spread of the disease, adult cattle can be vaccinated. All animals that have been treated with the live vaccine should be permanently identified in some way such as an earmark.

Humans can also contract this disease.

### Vibriosis

Vibriosis causes temporary infertility.

#### Symptoms

The most obvious sign is when females, particularly heifers, keep returning to the bull for mating, or have an irregular oestrus cycle. Only about 5% of the herd will abort, and this is often associated with a retained placenta.

The disease mainly affects first-calf heifers as the animal will develop immunity following infection. However, they can still spread the disease to bulls and other animals for a number of years.

Bulls remain infected for life once they contract vibriosis. Thus they should be inoculated in the spring of each year as a standard procedure to prevent them spreading the disease.



*Examples of earmarks that can be used to indicate the strains of vaccine used during a brucellosis eradication program.*

### Treatment

Once vibriosis has been diagnosed in the herd, all animals should be vaccinated. All heifers should be vaccinated at about 10 to 12 months of age for prevention throughout their life; bulls should be vaccinated each year in the spring.

### Infectious Bovine Rhinotracheitis (IBR)

Infectious Bovine Rhinotracheitis, sometimes called 'Red nose', is an infectious disease of cattle caused by a virus. The disease can manifest itself through upper respiratory tract and tear duct infections, or by venereal infection. Animals rarely die from IBR but the weakened immunity system in the respiratory tract can lead to pneumonia; other secondary bacterial infections can reduce rates of weight gain by 10–30%.

IBR is spread through:

- droplet infection from nasal discharge
- genital secretions and semen
- foetal fluids

### Symptoms

Incubation period ranges from 7 to 20 days. The severity of symptoms will depend on the strain of the virus and the susceptibility of cattle.

**Respiratory form** symptoms include:

- sudden onset of fever (temperature up to 42°C)
- animal is off its feed
- severe inflammation of nasal mucosa (Red nose) – irregular scabs
- serous discharge from the nose and the eyes
- conjunctivitis
- hyper salivation
- in some cases, sudden coughing

Recovery can take about two weeks

**Genital form** – symptoms include:

- If disease occurs in last trimester of pregnancy, foetus may be aborted and could be mummified. A live calf will be weak.
- Infected females will show signs of frequent urination, an elevated tail, a vaginal discharge, swollen vulva showing small fluid-like pustules on the surface.
- Infected bulls will have small fluid-like pustules present on the surface of the penis and sheath.

### Treatment

Once introduced, it is difficult and expensive to eradicate IBR. Animals tend to become unapparent carriers. Systematic testing and elimination of positives has been successful in some countries. Different type of inactivated vaccines are available. Officially-free countries restrict the use of these vaccines.

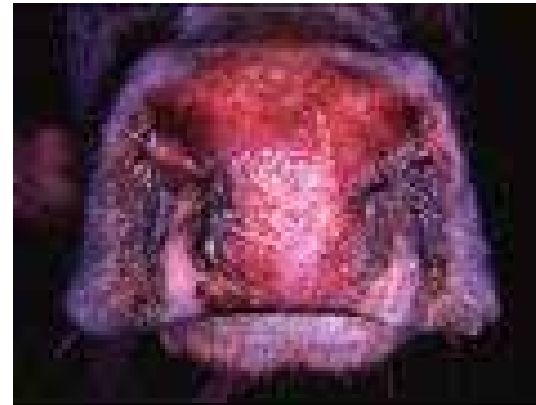

*IBR causes severe inflammation of nasal mucosa giving the 'red nose' symptom.*



*IBR – discharge from eyes and nose.*

## Clostridial diseases

Clostridial diseases include blackleg, tetanus; and botulism.

Clostridial organisms can survive in the soil for a long time. Most can also occur quite naturally in the gut of healthy animals where they cause no trouble, but contaminate the soil through the dung. When conditions are favourable for the uncontrolled growth of clostridial organisms, they produce powerful toxins (poisons) that are usually fatal.

### Blackleg

Blackleg usually affects younger animals between 6 and 24 months of age.

#### Symptoms

Marked lameness and pronounced swelling over the shoulders and thighs caused by gas in the subcutaneous tissues. When the swelling is pressed, a peculiar crackling sound can be heard. Infected animals have foul-smelling yellowish-white faeces and the hindquarters are dirty. Calves become dull and weak, lose weight, the eyes appear sunken, breathing is rapid, and body temperature drops below normal.

The disease is almost always fatal within 12 to 36 hours.

#### Prevention

Vaccination is the most practical method of combating this disease. Calves are normally vaccinated at weaning.

### Tetanus

Tetanus is caused by a clostridial bacteria that is commonly found in soil and animal faeces. Spores are resistant and persist for many years.

The bacteria usually enter through deep puncture wounds on the body or feet, or through exposed surgical wounds such as castration. Bacterial spores can remain inactive or incubate for five days to three weeks but then multiply rapidly in the body producing toxins that affect the nervous system of the animal.

#### Symptoms

The disease can last for up to 10 days and is nearly always fatal.

Muscles in the head, neck and tail become stiff with restricted jaw movement—referred to as ‘lockjaw’.

The animal eventually cannot stand and may fall over showing muscle spasms with outstretched limbs.

Death is common due to muscular spasms with paralysis of the respiratory muscles.

#### Prevention

Good hygiene should be practiced when working with animals, and all surgical wounds should be treated promptly.

Animals can be vaccinated with tetanus toxoid or polyvalent (multi) clostridial vaccines as part of routine husbandry in susceptible animals or locations.



*Blackleg – identified by bubbly feel under the hide. A post-mortem examination reveals a blackish-red discoloration with a ‘bubbly’ appearance.*



*A calf with tetanus following castration. Note the rigid limbs caused by muscle spasm.*

## Botulism

Botulism is caused when animals ingest toxins produced by bacteria commonly found in soil or decaying plant matter, on dead and decaying carcasses, or in feedstuffs contaminated with dead animals such as dead rodents or snakes. It is often associated with phosphorus and/or protein deficiency when cattle chew bones of dead animals; in other cases, animals grazing on the edges of water courses can pick up toxins from decaying plant matter. There are distinct types or strains of botulism, commonly referred to as types A, B, C, D and E. The toxins affect the nervous system.

### Symptoms

Often the first sign is dead animals. Sick animals may show an unsteady gait, with paralysis starting in the back legs and advancing through the front legs to the jaw and throat. In advanced cases, the animal is lying down in an upright position with the head turned back and tucked into its flank or head and neck outstretched on the ground. Sometimes the animal may be found on its side moving their legs in a slow paddling motion unable to get up.

### Prevention

No treatment is available. Prevention is by supplying deficient nutrients such as phosphorus as supplements and by burning or deeply burying dead animals so that no other animals access them.

All animals should be vaccinated after weaning age with bi-valent Botulism Vaccine which covers the most common types of A and D. Some vaccines offer up to three year's protection.

## Other important diseases

### Footrot

Footrot is a bacterial disease that causes lameness. It can occur where the animal has an injured foot or is living in wet and muddy conditions.

### Symptoms

Lameness can be severe and the animal may show a raised temperature and mild fever. On examination, the hoof appears swollen and smells foul.

### Treatment

Use a paring knife to trim the hoof back to the infection, and remove any puss. After trimming the hoof, stand the animal in a footbath of saturated zinc sulphate for about 10 minutes, and give an intramuscular antibiotic. A foot bath 1800mm long, 700mm wide and 150mm deep full of water will require about 0.6kg of zinc sulphate.



*An advanced case of botulism with the head turned back and tucked into their flank.*



*Botulism resulting in paralysis and excessive salivation due to impaired swallowing.*



*Footrot between hoof claws.*

## Anthrax

### Symptoms

Anthrax causes sudden death.

A dead animal is commonly the first sign of anthrax, and it should be suspected in all cases of sudden death without any forewarning. Symptoms can include a black tar-like blood running out of all body orifices, particularly the anus, vulva and nostrils. Anthrax is dangerous to both humans and other animals. If anthrax is suspected, do not carry out a post mortem as this increases the risk of contaminating people and pastures.

### Treatment

Burn the carcass or bury it deeply in a pit lined with lime. Promptly vaccinate all other animals in the herd to prevent the disease from spreading.

## Foot and Mouth Disease (FMD)

This is a highly contagious viral disease that affects cloven-hoofed animals such as cattle, buffalo, sheep, goats and pigs.

### Symptoms

The disease is characterised by the appearance of blisters on the mucous membranes of the tongue, lips, palate, cheeks, on the skin and around the dewclaws of the feet, and on the teats and udder. The presence of blisters in the mouth stimulates a profuse flow of saliva that hangs in strings from the mouth of the infected animal.

### Treatment

Immediately notify the nearest government agency or office if this disease is suspected. The disease can be controlled by vaccination.

If the disease is suspected, the farm should be quarantined and the area thoroughly disinfected with a strong solution of sodium hydroxide (lye) or formalin. All infected animals showing clinical signs must be treated with alum and gentian violet or sodium hypochlorite.

In most countries, all infected animals and other cloven-hoofed species on the same farm are destroyed to contain the spread of the disease. This is effective but expensive.

## Hemorrhagic Septicaemia (HS)

Hemorrhagic septicaemia is a significant disease in South-East Asia and is a highly fatal disease of cattle and water buffalo. HS is transmitted when they ingest or inhale the causative organism through direct contact with infected animals or with contaminated articles.

In endemic areas, up to 5% of cattle and water buffalo may normally be carriers, but the carrier rate can increase above 20% for a few weeks after an outbreak.

The worst epidemics occur during the rainy season, in animals in poor physical condition. Stresses such as a poor food supply are thought to increase susceptibility to infection, and close herding and wet conditions seem to contribute to the spread of the disease.

### Anthrax deadly to humans

Anthrax is deadly to humans. If suspected, do not carry out a post-mortem examination without veterinary advice.



FMD lesions on tongue and mouth

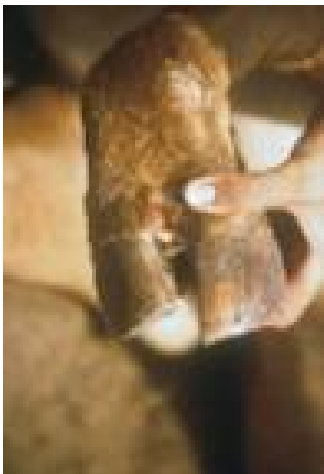

FMD between the hoof claws



On-farm biosecurity such as a lime foot bath will reduce the risk of new cattle bringing diseases such as FMD into an area.

The organism can survive for days in damp soil or water, but are not found in the soil or pastures after 2 to 3 weeks.

### Symptoms

The first signs are fever, dullness, and reluctance to move. Salivation and a serous nasal discharge develop, with oedema in the pharyngeal region. These swellings spread to the ventral cervical region and brisket. The mucous membranes are congested.

The animal suffers respiratory distress, and usually collapses and dies within 6 to 24 hours. Mortality is nearly 100% unless the animal is treated very early in the disease; few animals survive once they develop clinical signs.

### Treatment

Antibiotic treatment is effective if it is started very early, during the pyrexia stage. Various vaccines can provide protection for 6 to 12 months.

## Bovine tuberculosis

Bovine tuberculosis is a respiratory disease.

### Symptoms

Specific symptoms are difficult to detect in live animals. In advanced cases, the coat may be rough and dry, with the animal appearing rundown, but these symptoms are similar to those in several other diseases and cannot be seen as conclusive. The most reliable test is the 'Tuberculin Test', normally given in the caudal fold under the butt of the tail, which will cause a characteristic swelling under the skin within 72 hours.

### Treatment

There is no economic method of treating animals for tuberculosis. Infected animals must be destroyed to prevent its spread to other animals and humans.

## Johne's Disease

Johne's disease is rarely seen in cattle under two-years-old, although infection normally starts from a young age. The animal can appear normal and healthy during the incubation period but routinely pass the bacteria in faeces without showing signs of illness. Animals become infected by eating contaminated pasture, water and other food; those in housed areas or confinement are most at risk due to their exposure to faecal material.

### Symptoms

Diarrhoea and excessive thirst with progressive emaciation with 'bottle jaw' (fluid swelling around the lower cheeks down to the lower jaw).

### Treatment

No vaccine or treatment is available; infected animals should be slaughtered, burned or buried deeply. Routine testing and slaughter of animals that test positive (blood test) to the disease need to be considered in order to eradicate this disease.



'Bottle jaw' can be a sign of worms or Johne's Disease.

### Ephemeral Fever (3-day sickness)

Ephemeral Fever is caused by a virus transmitted during the bite of sandflies or midges. The fever is not normally life-threatening, but the animal may die if it suffers from heat stress. Younger animals are more susceptible than older animals. Bulls that have been severely affected can become sterile. Animals that recover usually develop a lifelong immunity.

#### Symptoms

The animal develops a fever with a high temperature, looks dull and listless with drooped ears and does not want to eat. It appears to have joint pain, will not want to walk and will often choose to lie down in shade. The disease will spread quickly through the herd, although not all animals will be affected.

#### Treatment

Try to move the animal into a shady place, supply it with water, and leave it to recover in peace.

Cattle over six months of age can be vaccinated with a modified live vaccine.

### Scours and diarrhoea

The problem is caused by bacilli normally present in the colon in healthy animals. The numbers of bacilli build up and become harmful if the animal is not well fed or is not being fed a balanced ration.

Calf scours are caused by an interaction between the environment, the health of the calf and the presence of disease-causing bacteria, viruses and protozoa. These pathogens are shed in low, but increased, numbers in the manure of cows around the time of calving, and in much greater numbers in the manure of scouring calves and unaffected calves up to six months of age.

#### Symptoms

Affected animals have liquid faeces that may be discoloured. The hindquarters and tail are dirty and covered in faecal material.

#### Treatment

Calves should be allowed to drink as much colostrum as they want as it contains antibodies that assist the calf to build resistance to these diseases.

Sulphur drugs and broad-spectrum antibiotics are best given orally.



*Ephemeral Fever*



*Calf scours*



Level 1, 165 Walker Street, North Sydney NSW 2060  
Ph: +61 2 9463 9333 Fax: +61 2 9463 9393  
[www.mla.com.au](http://www.mla.com.au)





# Module 6

## Forages and pastures

Contact:

Meat & Livestock Australia  
Level 1, 165 Walker Street  
North Sydney NSW 2060  
Ph: 02 9463 9333 Fax: 02 9463 9393  
[www.mla.com.au](http://www.mla.com.au)

Published by Meat & Livestock Australia Ltd

ABN 39 081 678 364

June 2011

©Meat & Livestock Australia Ltd 2011

ISBN 9781741915792

Care is taken to ensure the accuracy of the information contained in this publication. However MLA and the contributors to this publication cannot accept responsibility for the accuracy or completeness of the information or opinions contained in the publication. You should make your own enquiries before making decisions concerning your interests. MLA accepts no liability for any losses incurred if you rely solely on this publication.

The inclusion of trade or company names in this publication does not imply endorsement of any product or company by MLA or any contributor to this publication. MLA and the contributors to this publication are not liable to you or any third party for any losses, costs or expenses resulting from any use or misuse of the information contained in this publication.

Meat & Livestock Australia acknowledges the matching funds provided by the Australian Government to support the research and development detailed in this publication.

Reproduction in whole or part of this publication is prohibited without prior consent and acknowledgement of Meat & Livestock Australia.

# Module 6

## Forages and pastures

Forages are the cheapest sources of feed for beef cattle. This module outlines issues involved in growing forages and pastures for beef production in South-East Asia.

Forage species planted must be suited to the soil and the climate, and also to the farming system. Forages are only as productive as the level of management and fertility applied.

### Contents

<b>What are forages?</b>	2
<b>The soil</b>	2
Soil physical characteristics	3
Soil fertility, pH and salinity	3
<b>Plant adaptation</b>	4
<b>Forages in farming systems</b>	4
<b>Selecting forage and pasture species</b>	5
<b>The value of legumes</b>	7
<b>Establishing forages</b>	7
<b>Managing the forage</b>	10
<b>Soil fertility and fertilising</b>	10
<b>Weed management</b>	12
<b>Appendices</b>	13
Fertilising	13
Inoculating legume seed	15
Further information	15



*Forages to be harvested to feed cattle in pens*



*Local grasses harvested from an irrigation bund to be carried to penned animal.*



*Cattle grazing sown pasture.*

## What are forages?

Forages are plants that are grown for the leaves to be used to feed livestock. They can be harvested (cut and carry) for animals in pens or grazed in a field. Grasses sown for cattle to graze are often called 'sown pastures' while grasses around communal areas are generally 'natural grassland'.

Smallholders with a couple of cattle may cut-and-carry forage growing on roadsides or wasteland whereas commercial beef production is generally based on sown forages and pastures. Sown forages must be suited to the local management system and soil to remain productive.

### Some basic principles

Any forage planted must be suited to the local soil and climate if it is to remain productive. Plants suited to clay soils with high rainfall will not grow in sandy soils in semi-desert; plants that need fertile soils will not grow well in acid soils. Plants from temperate regions will not grow in the lowland tropics but may at high altitude.

- In general, a grass species will grow in a wider range of environments than a legume species.
- Grass growth is totally dependent on the fertility of the soil whether this is natural or supplemented by manure or fertiliser. The more nitrogen, the better the growth.
- Grasses need nitrogen to provide good bulk of good-quality feed; legumes make nitrogen and provide less bulk but higher quality feed.
- Forage grasses give their optimal yield of good-quality leaf when cut about every six weeks. Longer intervals between harvests produce more material but it is more fibrous and of poorer quality.
- Grasses are the best plants for improving the health of the soil—its physical structure, organic matter, and all the beneficial soil organisms such as earthworms, insects and good fungi.

## The soil

Soil is the basic resource and the farmer's most important asset. It can be improved for better production with good management but lost through poor management. Nothing can replace soil that is lost.

The natural fertility of a soil is influenced by the parent material from which it has been formed. Some soils remain where they were formed; other soils have been moved by water and deposited elsewhere. These alluvial soils tend to be more fertile. Perhaps the most fertile soils are those of geologically recent volcanic deposits, as commonly found in some Indonesian islands.

Organic matter builds up in the soil under the natural vegetation over the ages. It gives the soil structure and holds plant nutrients, but is quickly lost under frequent cultivation and high temperatures. Soils in the tropics that have been cultivated for centuries now have low levels of organic matter. Grasses are the best way to restore organic matter and soil health; they also provide good groundcover and prevent erosion.

### Soil physical characteristics

It is possible to tell much about a soil by looking at it, feeling it, and doing some simple tests. For example, a dark soil indicates a fair level of organic matter while a blue-grey layer at depth indicates poor drainage. Red soils in the humid tropics are often acid and infertile.

#### Soil texture

Texture often determines which plants will grow in the soil. Soils can be broadly classed as light (eg sands and sandy loams), medium (eg clay loams, light clays), and heavy (eg medium and heavy clays). Soil texture influences features such as its moisture-holding capacity, the rate of water infiltration and drainage, and risk of erosion.

#### Soil structure

Good soil structure allows water and air to move freely into the soil, reducing waterlogging and water run-off. Plant roots can explore a larger volume of soil and thus have access to more water and nutrients. Soil structure deteriorates with the loss of organic matter under regular cultivation but is improved by the very fine root system of grasses.

#### Soil depth

A deep soil can hold more water and nutrients, but layers of impermeable clay or salinity can limit effective rooting.

### Soil fertility, pH and salinity

#### Soil fertility

All plants require a range of major and minor nutrients for growth (Table 6.1); soil fertility describes the ability of a soil to hold and release the range of nutrients for plant growth.

Table 6.1. Essential nutrients for plant growth

Macronutrients	Micronutrients /Trace elements
Nitrogen (N)	Chlorine (Cl)
Phosphorus (P)	Iron (Fe)
Potassium (K)	Boron (B)
Calcium (Ca)	Manganese (Mn)
Magnesium (Mg)	Zinc (Zn)
Sulphur (S)	Copper (Cu)
	Molybdenum (Mo)
	Nickel (Ni)

Excess of some minor elements can cause toxicity. Different species require different levels of nutrients.



The fine root systems of grasses improve soil texture and organic matter, and hold the soil against erosion.



Grass for frequently wet soils – (*Paspalum guenoarum*).



*Legume for seasonally dry regions with less fertile soils – Stylo.*



*Elephant grass produces great bulk of forage with good rainfall and high soil fertility – but much of it may be low digestibility stem if not cut frequently.*



*Grass with much leaf and little stem – Brachiaria hybrid.*

## Soil pH

pH is the measure of acidity or alkalinity, with most soils between pH 4.5 (acid) and pH 9 (alkaline). Soil pH affects which species will grow naturally due to its impact on nutrient deficiency or toxicity. Soil pH can be measured using an electronic pH meter or with a soil test kit.

## Soil salinity

Plant growth can also be affected by the presence of salt in the soil. Salt may have come from pre-historic or historic flooding by sea water or saline irrigation water; it can be brought to the soil surface by a rising water table.

## Plant adaptation

Some plants grow in deserts, others in swamps; some grow in fertile soils, others in infertile soils; some grow in cold climates, others in hot climates. Temperate species cannot be grown in the tropical lowlands but may grow at higher altitudes. There is considerable variation between and within plant species in their adaptation to various soil conditions.

Many soils in the high-rainfall tropics are strongly leached, and tend to be very acid. Plants growing on these acid soils can tolerate high levels of aluminium and low levels of phosphorus. Other species, such as the legume leucaena, do not tolerate acid conditions. Salt-tolerant species can be selected for sowing in salt-affected areas.

Grasses are adapted to grazing (or frequent cutting) because their growing points are near ground level; thus animals eat the leaves and stems without destroying the growing point. Plants from more heavily grazed natural environments tend to be more prostrate, with stems that root down on the soil surface (stolons) or even creep below the soil surface (rhizomes). Grasses from semi-arid regions tend to be clumpy and taller with deeper root systems.

Other broad-leaf branched plants have growing points at the tips of the branch; when these are removed by grazing or cutting, new growing points have to develop from buds on the stem.

Thus a farmer must select plants suited to his local environment and production system. Poorly adapted plants will soon die out and disappear.

## Forages in farming systems

Forages are as much a part of a farming system as the crops that are grown and the animals that are kept, and should be treated accordingly.

Before deciding which and how much forage to grow, the farmer needs to consider the following:

- How many animals have to be fed?
- What level of production is expected?
- Will the forage be grazed or cut-and-carry?

- How will livestock be fed during the dormant (cool or dry) season?
- How much land is available for planting forage?
- What labour is available for planting and managing the forage?
- What finance is available?
- Are there other sources of feed and what is their feeding value?
- Will the forage be permanent or short-term forage (will the forage be part of a crop rotation?)
- Which forage species are suitable for the soil and environment?
- Which forage species are best suited to the farming system?

### How much and what to plant

Enough forage has to be planted for the number of livestock to be fed. As a rough calculation:

- An animal weighing 400kg can eat 2.5% of its body weight as dry matter each day (10kg DM/day or 3,650kg DM/year).
- A well-fertilised pasture producing 20,000kg DM/year should therefore support 5 or 6 head if all the feed was eaten.
- Waste from trampling and fouling in grazed systems and from losses in cut-and-carry systems will reduce carrying capacity to about three adult cattle for one hectare of good forage.

### Selecting forage and pasture species

Of the thousands of species of grass and legume in the world, a limited number have been selected by farmers and scientists for feeding their livestock. Many may be well known and available locally; other potentially more suitable species may need to be evaluated locally. Information to help farmers select good species at the local level has been made available through the 'Forage for Smallholder' project.

At the forage researcher level, potential species for local evaluation can be selected using *Tropical Forages: an interactive selection tool* ([www.tropicalforages.info](http://www.tropicalforages.info) in English) and (<http://indonesia.tropicalforages.info/> for Bahasa Indonesian).

There are a number of annual forages. Hybrid sorghums grow quickly and produce high yields of green material. They can be useful to provide feed early in the wet season but tend to produce their bulk when there is plenty of other forage available. Disadvantages are that being hybrids, new seed has to be purchased each year and that they require heavy fertilisation if they are not to quickly exhaust the soil's fertility.

Some food crops can produce high-quality feed as a by-product. For example, farmers with markets for baby corn can feed the remaining green maize plant at its peak nutritional value.

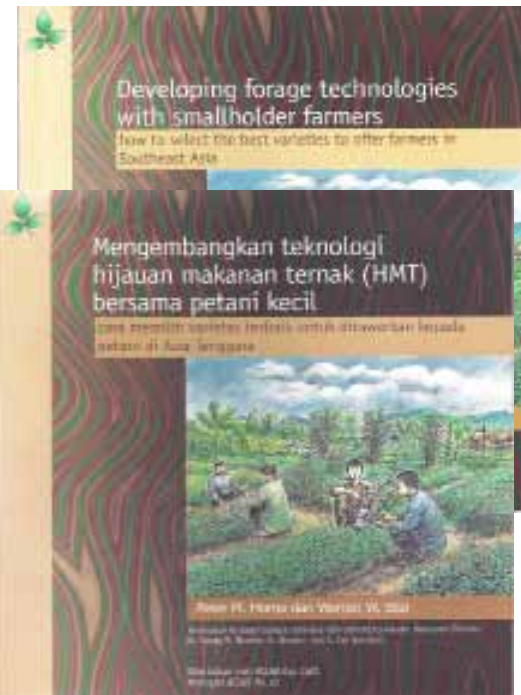

Useful booklets on selecting the most suitable species



Different species of grasses and legumes are suited to different environments and production systems. Seek local advice for the most suitable selections.



*Leucaena is the most nutritious forage but cattle may need a special rumen bug if it is a major part of the diet.*



*Nutritious leaf of young elephant grass*



*Much of the bulk of elephant grass cut at intervals greater than about 10 weeks is fibrous stem.*

## Anti-nutritional factors

Some sown forages can adversely affect livestock when fed as the sole ration. For example, the leaf of some setaria grasses has high levels of oxalate, which can tie up calcium in the animal's body and cause milk fever in high-yielding dairy cows. Many extremely valuable temperate or subtropical legumes (lucerne, medics and clovers) can cause bloat when eaten in excess. Some native legumes may be toxic or cause abortion.

Leucaena leaf has the highest nutritional value of any tropical legume but if cattle eat too much they may lose the hairs in their tails and lose body condition. Cattle can be given a special rumen bug that results in leucaena becoming a very valuable feed.

## 'Bigger is not always better'

Elephant grass (Napier grass, king grass) is probably the most popular grass grown for cut-and-carry systems. King grass is a valuable source of green fibre in feedlots where the ration is based on high-energy and high-protein concentrates. But its tall growth often means more fibrous stem and less leaf, and it may not be as nutritious as a lower-growing but more leafy grass for an animal getting only forage in a pen on a farm.

The tall elephant or King grass needs good management and high fertility.

- High fertility to remain productive. Large amounts of plant nutrient are removed in a cut-and-carry system or are tied up in the heavy root system. (See section on Soil fertility and fertilising on page 10.) Large amounts of manure or chemical fertiliser are needed to stop the decline in both plant and animal productivity. These tall grasses mature rapidly.
- The green leaf of a grass has the highest nutritional value; the stem contains more indigestible fibre, and hence has lower feeding value.

Elephant grass and its hybrids start to develop stems fairly soon after cutting—by 5 weeks, top growth may be 50% stem, by 10 weeks 75% stem. In a cut-and-carry system, many farmers allow grasses to grow too tall and too stemmy. Even if animals are forced to eat these fibrous stems by chopping, they will not perform well. Lower-growing, leafy species often produce more edible feed than taller 'stemmy' species.

## Key points

Plant forages that are suited to the local environment and production system.

Large cattle imported from Australia need more feed than smaller local breeds.

Growth of grass depends on the amount of nitrogen in that system.

Well-fertilised grasses produce most bulk; legumes provide more protein for feed and nitrogen for the grass.



## The value of legumes

The legume family includes beans, peas, groundnuts and some leafy forage types. Legumes are valuable as forages because they:

- provide better quality feed (higher in protein and more digestible) than grasses
- make 'free' nitrogen from the atmosphere to boost grass growth

Legumes have small nodules on their roots that hold special bacteria (rhizobia). These rhizobia can 'fix' atmospheric nitrogen and turn it into protein. The rhizobia have a symbiotic relationship with the host plant; the rhizobia provide nitrogen to the plant, the plant provides energy to the bacteria. This 'loss' of energy to the rhizobia reduces growth of the plant and thus legumes generally produce less bulk than grasses—better quality but less quantity.

The protein-rich leaves, stems and seeds can be eaten by livestock or fall to the ground to provide 'fertilising' nitrogen to the adjacent grasses. The nodules also slough off the roots to enrich the soil.

Many forage legumes may fix about 100kg N/ha/year under good growing conditions and with adequate phosphorus and sulphur in the soil. The amount of nitrogen fixed is closely related to the amount of legume leaf; a poor stand of heavily grazed legume may fix only 10kg N/ha.

Crop legumes that produce peas or beans tend to transfer nearly all their protein from their green leaf into the maturing bean; thus dry legume stubble from a crop such as soybean does not have much protein. Residues from crop legumes that have green leaf at harvest, such as groundnut haulm, make good-quality hay.



*Nodules on legume root*

## Establishing forages

### Land preparation

Any plant (weed or crop) already growing will compete with the new small seedlings of grasses for moisture, nutrients and light. To minimise this competition, existing plants should be removed by cultivation or killed with a herbicide such as glyphosate. Cultivation will also provide a fine, firm seedbed for the small pasture seed.

In erosion-prone areas, run-off water can be diverted away from the cultivated area using diversion banks, or by leaving uncultivated contour strips of natural grass.

### Planting

Forages can be established vegetatively or from seed. Each approach has advantages and disadvantages. Often the main considerations are the size of the area to be planted, the availability of planting material and the cost of labour.



*Useful booklets on establishment and management*



Stems or sets



Splits



Stolons



Rhizomes

Table 6. 2 summarises the advantages and disadvantages of the systems of establishment.

Table 6.2. Advantages and disadvantages of method of establishment

For	Against
<b>Vegetative planting</b>	
<ul style="list-style-type: none"> <li>• reliable</li> <li>• establishes rapidly</li> <li>• early production</li> <li>• weeding easier between rows</li> <li>• does not need full cultivation</li> <li>• can plant late in season</li> <li>• good for small farmers</li> </ul>	<ul style="list-style-type: none"> <li>• labour intensive</li> <li>• must have enough fresh material</li> <li>• may need to first establish a nursery for planting material</li> </ul>
<b>Sowing seed</b>	
<ul style="list-style-type: none"> <li>• fast</li> <li>• easy</li> <li>• good for larger areas</li> </ul>	<ul style="list-style-type: none"> <li>• seed often expensive</li> <li>• seed quality declines with time</li> <li>• must plant early in wet season</li> <li>• needs favourable weather</li> <li>• slow establishment</li> <li>• can be smothered by weeds</li> </ul>

### Vegetative planting

Forages can be established using various parts of the plant—

- stems or sets (eg *Pennisetum purpureum*)
- splits (eg *Panicum maximum*)
- stolons (eg *Arachis pintoj*, *Brachiaria humidicola*)
- rhizomes (eg *Arachis glabrata*)
- stem cuttings or seedlings (eg *Leucaena leucocephala*)

All planting material should be fresh and free of disease. Plant spacing and layout will vary according to species, position in the landscape and type of management. Where feasible, plant in rows for ease of furrowing before planting and weeding later.

### Planting from seed

- **Cheap seed:** This may not be good seed, and a failed establishment may make it expensive in the long term. The cost of seed of any particular species will depend on the ease of harvest, where it is produced and the local labour costs.
- **True variety:** Be sure that the seed is really that of the variety required. Buy seed from a reputable source and check the label.
- **Seed quality:** Quality (as purity and germination percentage) should be shown on the label. Purity shows how clean the sample is—make sure there is no seed of new, potentially serious weeds. Germination details include the percentage germinable and hard/dormant seed. Less than 50% viable seed indicates poor seed health.
- **Dormancy:** The seed of many grasses is dormant immediately after harvest but germination generally improves over the next six months.

- **Seed storage:** Seed often has to be stored before sowing. Its germination can decline rapidly if it is stored at high temperature and humidity. To maintain seed quality:
  - Seed should be dry (<10% moisture) before storage. As seed will absorb moisture from a humid atmosphere, it may have to be stored in sealed moisture-proof bags or containers.
  - Keep seed in cool, dry conditions, for example in an air-conditioned store.
  - Smaller seeds tend to have shorter shelf life. Grass seeds are much more delicate than larger hard legume seeds.
  - Protect from insects and mice.
- Check the germination before planting.

### Seed treatments

- **Coated seed:** Some commercial seed is coated by the seed supplier as it makes fluffy seed flow through machinery. Coating adds considerably to the weight of small light grass seed, resulting in fewer seeds per kilogram and a higher price per kilogram of germinable seed. Sowing rates should be adjusted for the seed to coating ratio, which may be as high as 1:10.
- **Scarifying legume seed:** The hard seedcoat of legumes is often impermeable to water, preventing germination. The 'hard' coat gradually breaks down in the soil but prevents immediate germination of all seed which might then die if conditions turn dry. Too much hard seed may result in poor immediate germination and poor competition against weeds. The proportion of hard seed can be reduced by scarifying the seed coat mechanically using abrasives (such as sand paper). Hot water or dry heat can be used in some species but the seed must not be cooked. The best immediate germination will depend on the reliability of rainfall, but scarification to give about 50% immediate germination is a good compromise.
- **Inoculation of legume seed:** For legumes to fix nitrogen, they need the right strain of rhizobium bacteria. Some legumes can use native rhizobia in the soil, others are highly specific. Where there is doubt, a culture of the specific bacterium is coated over the seed—called inoculation (See Appendix).

### Sowing

Grass seed is much smaller than that of a grain crop, and the small seedlings are delicate. The grass seed will germinate best when pressed into a moist fine, firm seedbed, but not too deep. Small seeds are best sown as close to the surface as possible, and larger seeds at 2–5cm. Small seed can be broadcast over the surface, covered very lightly or rainfall can be allowed to carry the seed into the soil. Sowing in rows makes it easier to control weeds by hand or hoe.

Sow most pasture species at 2–5kg seed/ha, and large forage legume seeds such as cowpea at up to 30kg/ha.



*Seed of grasses is much smaller than that of a crop like rice, and the seedlings are more delicate.*

### Key point

Sow or plant into a moist, weed-free seedbed.



*Seed can be sown in rows or broadcast.*



Mostly leaf; ideal for cutting (1m tall) ✓



Elephant grass left too tall for good quality (top) and cut too low for fast recovery (bottom),



Phosphorus deficiency may show up as purplish colouration in seedlings.

## Managing the forage

### Grazing and cutting (defoliation)

- Cut or graze to obtain optimum feed quality without weakening the plants. Feeding value declines rapidly with age of regrowth as more fibrous stem develops. Longer intervals between cutting may result in higher yields of herbage but animal production is usually poorer because of lower quality.
- Always leave some green leaf on the plant after cutting. Severe cutting or heavy grazing will slow recovery. With taller-growing grasses (elephant, guinea), it is best not to cut below 300mm from the ground.
- Retain a significant amount of leaf on legumes to help recovery.

Plant nutrients are removed from the soil when the forage is cut and carted away or when cattle graze but are locked away at night. Plant nutrients must be returned if the forages are to remain productive.

### Soil fertility and fertilising

Nutrient levels can be tested in soil analysis laboratories but it is best to approach a local agricultural research station or district extension officer for more specific information about your locality.

It is often easier to look for visual symptoms of deficiency or toxicity, and to assess plants for vigour or abnormally pale colour, yellowing of leaves or stunted growth. The experienced forage manager can recognise and diagnose a problem.

Nitrogen deficiency in grasses is seen as pale green foliage, dead leaf tips and poor growth, while pale leaf colour might indicate sulphur deficiency or poor nodulation in a legume. Phosphorus deficiency may appear as a purplish colour in seedlings. Potassium deficiency is seen as yellow or dead leaf tips or edges but these symptoms can also be seen during dry or cold conditions when the plant cannot extract potassium from the soil.

pH is an easy-to-measure, valuable tool in interpreting plant response to soil conditions since it influences the availability of essential nutrients, and of elements such as aluminium and manganese that might be toxic to plants. Plant growth is usually best in a slightly acid soil (pH 6–7) when most nutrients are readily available, but many tropical species are well adapted to acid soils.

Knowing the pH can give a guide as to what deficiencies or toxicities may exist at a particular site (Table 5.3).

Table 6.3. Plant nutrient deficiencies and toxicities influenced by pH

Very acid soil		Very alkaline soil	
Deficiency	Toxicity	Deficiency	Toxicity
P, Mo	Al, Mn	Fe, Mn, Zn	rare

## Soil fertility and plant growth

Different species need different levels of nutrients to grow vigorously. In general, grasses need high N and P although some bluegrasses (eg *Bothriochloa* species) grow well on lower levels than guinea grasses (*Panicum* species). Legumes make their own N but need more P and S than grasses.

However, under 'the rule of limiting factors', the vigour of growth is controlled by the nutrient most limiting—even if all others are adequate. The plant can only grow to its full potential when all necessary nutrients are adequately supplied.

The levels of applied nutrient recommended in grazing systems where nutrient cycling takes place are shown in Appendix 1.

Farmyard manure is the most common form of fertiliser used in many countries, but it is important to consider the large amount of manure required to replace the nutrient removed in the forage.

The alternative to use commercial chemical fertilisers, which contain much higher levels of the various nutrients (Appendix 1).

One approach is to develop a fertiliser program that replaces the net loss of nutrients from the system, that is the nutrients removed from the soil in the forage or in the animal, and not recycled. Some nutrient is returned to the soil in the dung and urine under grazing, but not in a cut-and-carry system.

Nutrients are also lost from the system by:

- leaching (washed through the soil by rain and irrigation)
- erosion of topsoil
- chemical activity in the soil
- being bound up in plant roots and other organic material in the soil
- burning crop stubble
- loss of nitrogen through nitrification or volatilisation

Thus it is difficult and expensive to maintain soil fertility and for the system to be truly sustainable.

Erosion takes the best topsoil with all its nutrients. Soil loss must be minimised, and a ground cover of vigorous grass is the best way.

### Key points

'The rule of limiting factors' — plant growth is limited by the nutrient in shortest supply, even if other nutrients are plentiful.

Knowing soil pH can help in determining suitable species and for diagnosing deficiency or toxicity problems.

Use enough of the right fertiliser to maintain the desired level of productivity.



*Potassium deficiency in maize: yellowing and death of leaf margins*



*Soil fertility can be maintained with manure or chemical fertiliser.*



*Heavy applications of manure are needed to keep grass productive.*



*Sowing in rows makes weeding easier.*



*Weeds can be a major problem when fertility runs down in an old pasture.*

## Weed management

Weeds will invade any open space. They grow quickly and soon compete with the sown species for water, nutrients and light, and so reduce productivity of the pasture.

Weeds may indicate a problem with pasture or forage management. Weeds take over if:

- pasture seedlings are suppressed by the already-established weeds
- pasture plants are weakened by being cut too low
- cattle eat out the palatable grasses through continuous over-grazing
- the sown grasses become weakened by declining soil fertility

Weeds at establishment can be controlled by hand-weeding, or spraying with a selective herbicide (eg 2,4-D will kill broad-leaf weeds but not the grass). Non-selective herbicides such as glyphosate can be used with appropriate shields if the sown species are in obvious rows.

It is almost impossible to remove weed grasses from a sown grass pasture with herbicide, and they would have to be dug out with a hoe or mattock.

While weeds in established pastures can be also controlled with a hoe or herbicide, the most effective control is through more lenient defoliation. Slashing annual weeds may prevent them seeding and tip the balance back in favour of the sown species. Herbicides should be seen as a last resort when other control measures have been unsuccessful—chemicals are expensive.

Weed control is best followed up by fertilising to boost the pasture grasses and make them more competitive.

### Key points

Poor, unpalatable or tough wiry grasses are weeds.

The best control of weeds is a vigorous pasture.

# Appendices

## Appendix 1. Fertilising

### Developing a fertiliser program

The amount of nutrient removed in a cut-and carry system can be calculated roughly from the approximate yield of forage and the chemical composition of that plant material.

(Yield of forage is normally expressed in terms of kilograms (kg) or tonnes (t) of dry matter (DM) per hectare. An example case could be of a well-fertilised tropical grass in the tropics producing an annual yield of 20 tonnes DM/ha.

Table 6.4 gives approximate concentrations of nutrients in the plant dry matter, and thus the amounts of nutrients that are removed in 20 tDM/ha of forage.

*Table 6.4. Typical critical nutrient levels in the dry matter of plants and the amount removed in 20 tonnes of forage DM.*

Nutrient	Concentration		Removal
	%	g/kg	kg/ha
Nitrogen (N)	1.5	15	300
Phosphorus (P)	0.2	2	40
Potassium (K)	1.0	10	200
Sulphur (S)	0.1	1	20
Calcium (Ca)	0.5	5	100
Magnesium (Mg)	0.2	2	40

(Note that concentrations of nutrients vary considerably between species, with age of regrowth and the amount of available nutrient in the soil; for example, nitrogen and potassium concentrations in grass may range from 0.5% to over 3%.)

Farmyard manure is the most common form of fertiliser used in many countries. Table 6.5 shows typical plant nutrient levels in fresh manure.

*Table 6.5. Approximate nutrient and moisture concentration in manure.*

	Nutrient in fresh manure (%)					
	N	P	K	Ca	Mg	water
Cattle	0.5	0.13	0.4	0.3	0.1	80
Sheep	0.9	0.22	0.7	0.2	0.3	65
Poultry	0.9	0.22	0.7	0.4	0.2	65

Thus it would take the following amounts of fresh cattle manure each year:

- to replace 300kg N @ 60 t/ha
- to replace 40kg P @ 30 t/ha
- to replace 200kg K @ 20 t/ha.

Applying 60 tonnes per hectare is equivalent to spreading manure at 6kg per sq. m. Fresh manure contains more water than does the more solid manure from the pen floor.

Commercial chemical fertilisers contain much higher levels of the various nutrients (Table 6.6).

Table 6.6. Nutrient concentration in some common fertilisers

Fertiliser	Nutrient (%)			
	N	P	K	S
Superphosphate	–	9	–	11
Triple superphosphate	–	21	–	1
MAP	10	22	–	1
DAP	18	20	–	2
Urea	46	–	–	–
Sulphate of potash ( $K_2SO_4$ )	–	–	41	18
Muriate of potash (KCl)	–	–	50	–
Sulphate of ammonia (SA)	21	–	–	24
Gypsum	–	–	–	18
Elemental sulphur (S)				100

Using the previous calculation:

300kg N = 650kg urea or 1430kg SA or 1670kg DAP

40kg P = 440kg superphosphate or 200kg DAP

200kg K = 490kg sulphate of potash or 400kg KCl

20kg S = 110kg gypsum or 180kg superphosphate or 20kg S

The plant takes up nutrients as molecules and does not differentiate between molecules from manure or chemical fertiliser; however, very high applications of urea may make the soil more acidic whereas manure dug into the soil will also improve soil organic matter.

Commercial fertilisers are generally expensive, particularly if imported and transported long distances. However, it is important to recognise the amount of nutrient removed in terms of the amounts of these fertilisers required to replace them, if only to be aware of the difficulty in maintaining the productivity of forages.

Table 6.7 . Typical levels of nutrients at planting and for maintaining productivity in a forage or pasture.

	N	P	K	S
	(kg/ha)			
At sowing	0–50	20–60	50–100	0–30
Annual maintenance	0–300	10–20	25–50	30



## Appendix 2

### Inoculating legume seed

Some legume species have a highly specific requirement for strains of *Rhizobium*.

Cultures of specific *Rhizobium* are sold as a black powder (peat dust) in packets which should be stored sealed, moderately cool and out of the sunlight.

Ideally, the rhizobial culture is mixed into a slurry with an inert glue such as methyl cellulose (eg Methofas) and mixed with the seed to provide a thin coating over the seed. (Sugar and milk powder have been used where methyl cellulose is not available.) The coated seed should then be spread out **in the shade** to dry before being sown as soon as possible.

If the legume seed is to be mixed with acidic fertiliser for sowing through machinery, the acidity will kill the rhizobium. It should be protected by pelleting the moist glue with a thin layer of fine lime (CaCO<sub>3</sub>) dust. When sowing some legume species (eg *Neonotonia wightii*) on acid soils, molybdenum trioxide (66% Mo)—but not sodium molybdate—should be incorporated into the lime to deliver 150–300 g/ha (100–200 g Mo/ha).

If a commercial rhizobium culture is not available, seed should be mixed with soil from around a vigorous plant of the same species. This soil should contain enough of the suitable strain of rhizobium to achieve effective nodulation.

## Appendix 3

### Further information

*Developing forage technologies with smallholder farmers – how to select the best varieties to offer farmers in Southeast Asia.* Horne, P.M. and Stür, W.W. (1999) *ACIAR Monograph No. 62*, 80 pp.

(<http://www.aciar.gov.au/publication/MN62>).

*Developing forage technologies with smallholder farmers – how to grow, manage and use forages.* Stür, W.W. and Horne, P.M. (2001). *ACIAR Monograph No. 88*, 94 pp.

(<http://www.aciar.gov.au/publication/MN088>)

Tropical Forages: an interactive selection tool” at

[www.tropicalforages.info](http://www.tropicalforages.info) or

<http://indonesia.tropicalforages.info/> for the Bahasa Indonesia version or on CD-ROM. Cook, B.G., Pengelly, B.C., Brown, S.D., Donnelly, J.L., Eagles, D.A., Franco, M.A., Hanson, J., Mullen, B.F., Partridge, I.J., Peters, M. and Schultze-Kraft, R. (2005).



Level 1, 165 Walker Street, North Sydney NSW 2060  
Ph: +61 2 9463 9333 Fax: +61 2 9463 9393  
[www.mla.com.au](http://www.mla.com.au)