

Mechanical Dock Levelers

Models CM, WL and WS

with Hydra-Cam™ Lip Extension

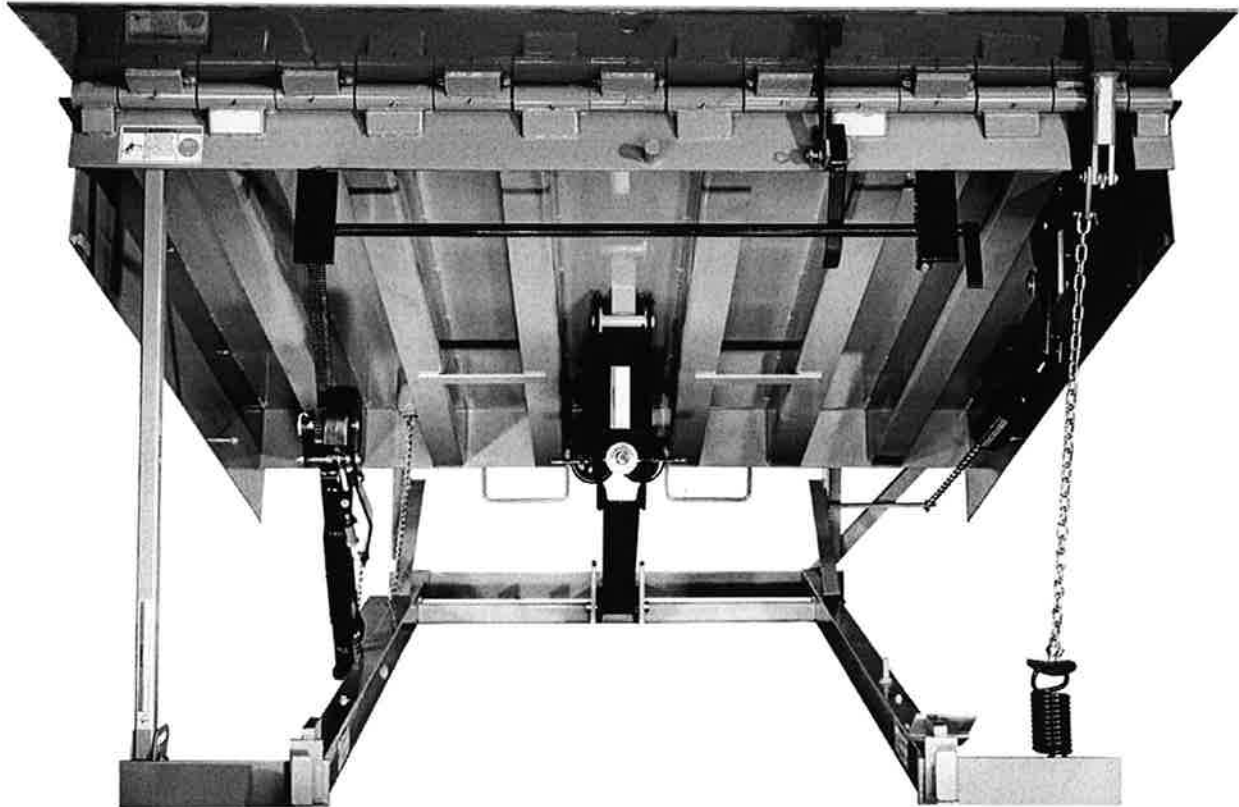

This manual applies to:

WL and WS dock levelers manufactured beginning: Carrollton
— December 11, 2001 with the serial numbers 19,001 and
higher; London — December 11, 2001 with the serial numbers
2,000,500 and higher.

CM dock levelers manufactured beginning: Carrollton
— September 2001 with the serial numbers 19,701 and
higher; London — November 1, 2001 with the serial numbers
2,000,000 and higher.

WARNING

Do not install, operate or service this product unless you have read and understand the Safety Practices, Warnings, and Installation and Operating Instructions contained in this manual. Failure to do so could result in death or serious injury.

User's Manual

Installation, Operations,
Maintenance, Parts

6001945A

ADJUSTMENTS

Use these instructions to adjust the leveler.

WARNING

Before servicing the dock leveler, always position traffic cones or a barricade behind the dock leveler to warn fork vehicle operators and pedestrians away from the leveler.

Always position traffic cones or a barricade in front of the leveler to warn against vehicle traffic.

Always notify a foreman or supervisor that you are working under the equipment.

Always make sure that the maintenance post is in the raised position before working under the dock leveler.

Always make sure that the overhead door is securely held in the raised position.

ADJUST LIP ASSIST WITH HYDRA-CAM™

Fig. 26

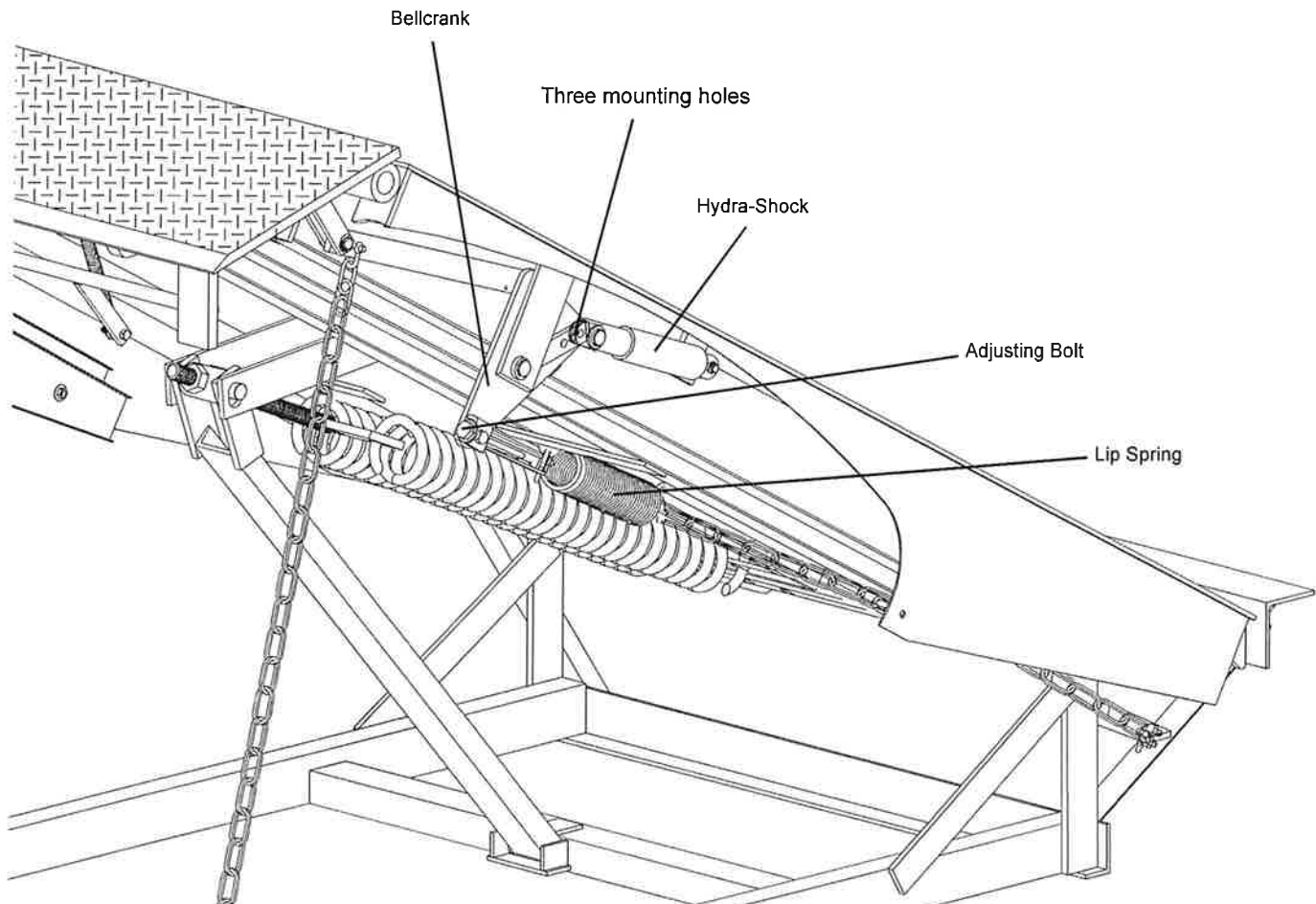

1. Ensure that lip hinges have been greased and all other pivot pins have been lubricated.
2. Fully raise the leveler and extend the lip. The lip should remain fully extended. Check that all lip assist pivot points are lubricated with light oil.
3. If the lip starts to fall, increase the lip spring tension by turning the adjusting bolt clockwise. Securely tighten locknut after adjusting.
4. Walk the leveler down approximately 12". The lip should start to drop very slowly.
5. If the lip does not start to fall, decrease the lip spring tension by turning the adjusting bolt counter clockwise. Securely tighten the locknut after adjusting.
6. Walk the leveler down an additional 6". The lip should fall to the pendant position. Further decrease lip spring tension if required. Securely tighten the locknut after adjusting.
7. After the lip spring has been properly adjusted, walk the leveler down to dock level. The lip should fall completely within 20 seconds.
8. Because the force of the Hydra-Shock is affected by temperature, the bellcrank has three mounting holes. The front of the Hydra-Shock is normally mounted in the outermost position. To adjust the Hydra-Shock, the lip must be pendant. If the lip falls too quickly, remove the spring clip and clevis pin and move it to a hole farther from the center of the bellcrank. If the lip falls too slowly, move the pin to the hole closer to the center of the bellcrank and secure with pin.

ADJUST MAIN SPRING COUNTERBALANCE

The main spring should be adjusted so that the leveler raises enough to fully extend the lip, yet still be easy to walk down.

NOTE:

1. Make sure that the hold down is operating freely. Excessive drag from the hold down may cause the leveler to raise too slowly.

2. Make sure that the lip hinge and deck hinges are lubricated and are operating freely. Excessive friction in the lip or deck hinges can prevent the lip from raising easily.

WARNING

Extended springs contain stored energy. Never attempt to remove main springs without completely removing the load from the springs first. Do not remove the main springs until the leveler and the lip are safely supported by a suitable lifting device.

Fig. 27

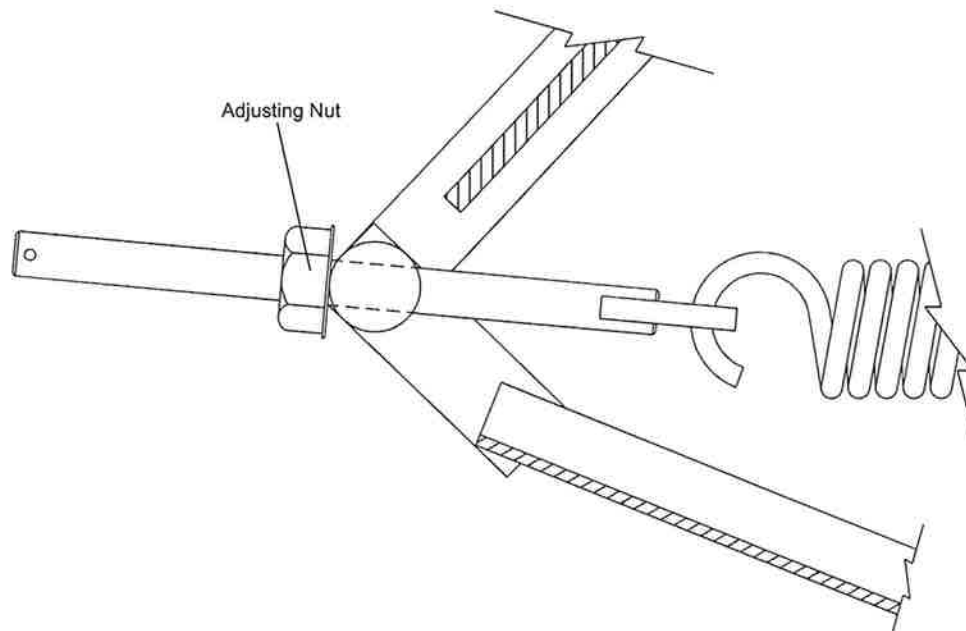

Tools Required: 1-1/2" open end wrench

1. If the lip does not fully extend, turn the adjusting nut clockwise to increase the main spring tension.
2. If the leveler is too hard to walk down, turn the adjusting nut counter-clockwise to decrease the main spring tension.

ADJUST HOLD DOWN ASSEMBLY

The hold down uses a friction brake to hold the leveler in position. The brake is released to allow the leveler to raise and the lip to extend.

Fig. 28

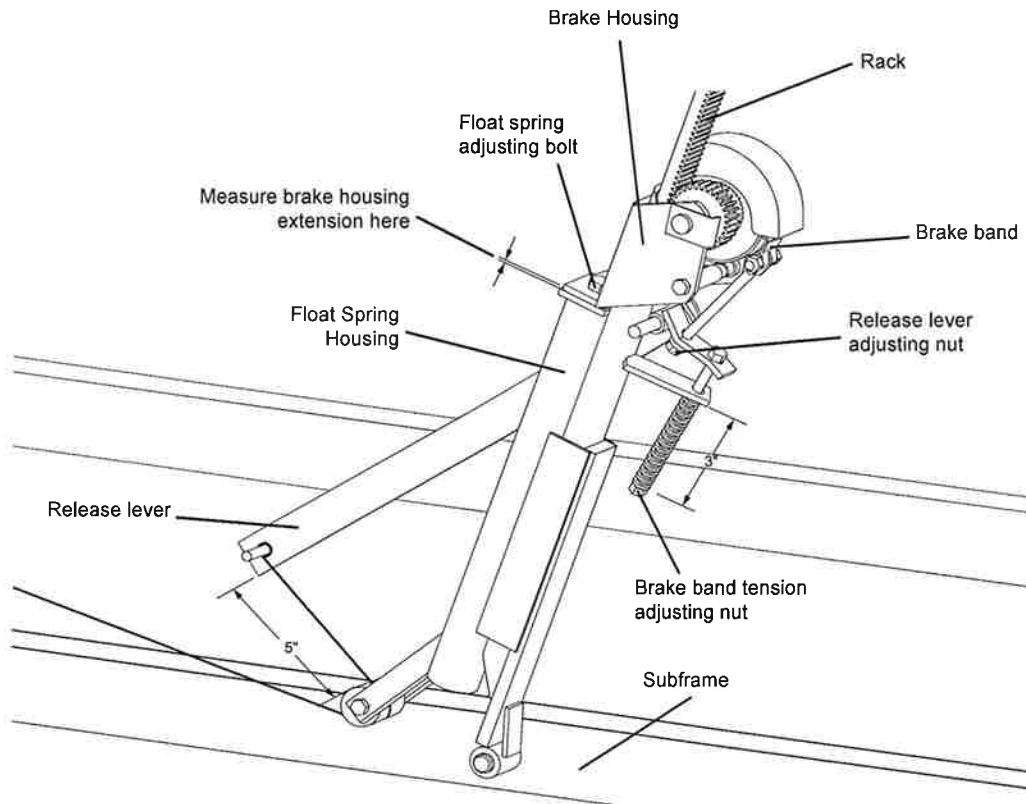

If the leveler raises without pulling the hold down release ring, inspect the gear teeth on the rack bar and pinion gear. Also make sure that the pinion gear is free to slide along the shaft to engage the clutch teeth on the side of the brake drum assembly.

If the leveler raises by itself, or if the leveler will not raise quickly when the hold down release ring is pulled, the hold down requires adjustment or repair.

To adjust the hold down to provide optimum performance the following adjustments are to be made in the sequence shown.

1. **Clean** the hold down rack and gears and apply a light automotive grease. **Do not lubricate between the brake band and brake drum.**

2. **Float Spring Adjusting Bolt** - The float spring (the spring inside the Float Spring Housing) compression is factory set at 3" from the bottom end of the float spring tube, and should not require adjustment. If the brake housing remains separated from the float spring housing at dock level, the dock leveler will not store properly at floor level. Increase the spring compression by turning the float spring adjusting bolt clockwise.

3. **Release Lever Adjusting Nut** - The end of the release lever should be approximately 5" away from the chain guide assembly, as shown. Adjust the release lever adjusting nut to maintain the 5" distance.

ADJUST HOLD DOWN ASSEMBLY, continued

- 4. Brake Band Tension Adjusting Nut** - The brake spring applies tension to the brake band. The spring is factory set to 3" compressed length, as shown in Fig. 28.

To check the adjustment of the brake spring to provide proper hold down float:

- Pull the hold down release chain and extend the lip.
- Engage the lip maintenance bar.
- Lower the leveler to dock level.
- Lift up on the lip until the brake housing moves away from the float spring housing.
- Measure the brake housing extension distance when the brake starts to slip.

When the dock leveler is forced upward, the brake should not slip until the brake housing has extended at least 1-1/2" away from the float spring housing. Tighten the brake band tension adjusting nut to increase the braking force if required. Do not tighten the brake spring to less than 2-1/2" long or the brake may not release properly. If the brake will not hold, make sure that the brake band is properly installed and there is no lubricant on the brake band or brake drum. Replace the brake band if necessary. If the brake band is contaminated by oil or grease, discard the brake band, clean the brake drum with solvent, thoroughly dry the drum and install a new brake band.

TROUBLESHOOTING GUIDE

WARNING

Before servicing the dock leveler, read and follow the Safety Practices on page 2 and the Operating Instruction section in this manual.

Be certain, before climbing into the dock leveler pit or doing any maintenance or repair under the dock leveler, that the maintenance post is raised and supporting the top plate in case of emergency. Failure to do so could result in death or serious injury.

Use the Troubleshooting Guide if ever the leveler fails to perform properly. Find the condition that most closely matches your situation, and make the recommended adjustments.

Problem	Possible Cause	Solution
1. Leveler will not raise when release ring is pulled.	<ul style="list-style-type: none"> a) Hold down release chain is binding. b) Hold down rack assy. is binding. c) Brake band dragging. d) Main springs require adjustment. 	<ul style="list-style-type: none"> a) Inspect release chain. b) Clean rack assy. and lubricate (Do not lubricate between the brake band and brake drum). c) Inspect brake band. Adjust hold down, if required, as shown on pages 22 and 23. d) Adjust spring tension, if required, as shown on page 21.
2. Leveler cannot be walked down.	<ul style="list-style-type: none"> a) Rack assy. is binding. b) Main spring over adjusted. 	<ul style="list-style-type: none"> a) Clean rack assy. and lubricate. (Do not lubricate between the brake band and brake drum). b) Adjust spring tension, if required, as shown on page 21.
3. Lip plate will not fully extend when leveler is raised.	<ul style="list-style-type: none"> a) Debris or corrosion in lip hinge. b) Debris or corrosion in rear hinge. c) Lip spring adjustment incorrect. d) Hold down not releasing freely. e) Main spring adjustment incorrect. 	<ul style="list-style-type: none"> a) Clean and lubricate lip hinge. b) Clean and lubricate rear hinge. c) Adjust lip spring as shown on page 21 and lubricate mechanism. d) Adjust hold down, if required, as shown on pages 22 and 23. e) Adjust main springs as shown on page 21.

TROUBLESHOOTING GUIDE, continued

Problem	Possible Cause	Solution
4. Lip plate will not start to extend when leveler is raised.	<ul style="list-style-type: none"> a) Lip chain is disconnected. b) Lip hinge is binding. 	<ul style="list-style-type: none"> a) Inspect and repair as required. b) Clean and lubricate the lip hinge.
5. Lip falls before it can be walked down to the vehicle.	<ul style="list-style-type: none"> a) Lip spring requires more tension. b) Front of Hydra-Shock is mounted in the cold weather position. c) Hydra-Shock missing or damaged. 	<ul style="list-style-type: none"> a) Adjust lip spring tension as shown on page 20. b) Move the Hydra-Shock front mounting pin as shown on page 20. c) Replace Hydra-Shock.
6. Lip plate does not fall when leveler is in working range.	<ul style="list-style-type: none"> a) Debris or corrosion in lip hinge. b) Lip spring adjustment incorrect. 	<ul style="list-style-type: none"> a) Clean and lubricate lip hinge. b) Adjust lip as shown on page 20 and lubricate mechanism.
7. Leveler will not travel below dock.	<ul style="list-style-type: none"> a) Safety legs or chain stuck or binding. b) Hold down binding. c) Main springs adjustment incorrect. 	<ul style="list-style-type: none"> a) Inspect safety legs and lubricate or repair as required. b) Inspect rack assy. and lubricate or repair as required. (Do not lubricate between the brake band and brake drum). c) Inspect main springs and adjust as required.
8. Leveler travels below dock when moves down.	<ul style="list-style-type: none"> a) Safety legs stuck in retracted position. 	<ul style="list-style-type: none"> a) Inspect safety legs and lubricate or repair as required. Check that return spring is properly installed.
9. Leveler does not follow when vehicle floor moves down.	<ul style="list-style-type: none"> a) Safety legs are engaging the frame. b) Hold down has insufficient float. 	<ul style="list-style-type: none"> a) Retract safety legs and lubricate or repair as required. b) Check float as shown on page 23 and adjust hold down, if required.
10. Leveler will not stay down on vehicle bed or in stored position.	<ul style="list-style-type: none"> a) Hold down requires adjustment or maintenance. 	<ul style="list-style-type: none"> a) Adjust hold down as shown on pages 22 and 23. Replace brake band or entire hold down if required.

PARTS LIST

Use this Parts List to determine the correct replacement part(s) for your dock leveler.

HOLD DOWN ASSEMBLY PARTS LIST

Fig. 29

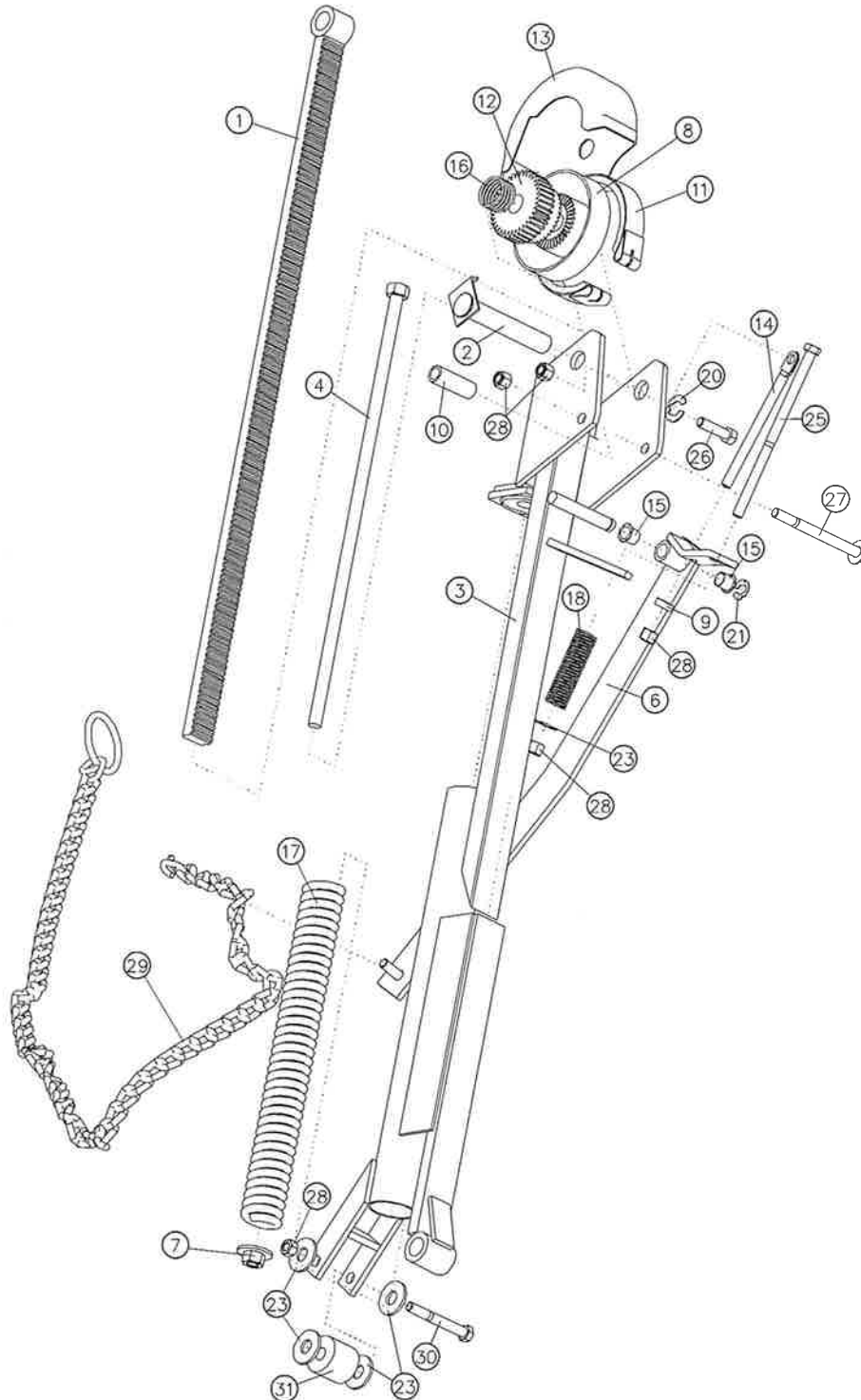

PARTS LIST, continued

HOLD DOWN ASSEMBLY PARTS LIST

Item	Quantity	Part Description	Part Number
1	1	Hold Down Rack Assembly	8-8786
2	1	HD Gear Pin Assembly	8-9575
3	1	HD Threaded Rod Assembly	8-9614
4	1	Release Lever Assembly	8-9475
5	1	HD Drum Assembly	8-8785
6	2	HD Band Spacer (Short)	586-0973
7	1	HD Band Spacer (Long)	586-1099
8	1	Brake Band	586-1485
9	1	Hold Down Drum Shield	341-012
10	1	HD Link Rod	216-257
11	2	Bushing - Nyliner (8L8-F)	821-030
12	1	Hold Down Gear Spring	333-037
13	1	Hold Down Spring - Lever	332-066
14	1	Upper Hold Down Pin	583-0003
15	4	Klipring - 3/4 (5304-75 Truarc)	236-110
16	1	Klipring - 1/2 (5304-50 Truarc)	236-106
17	2	PW 3/4 Bolt size - 13/16 hole	234-141
18	3	PW 3/8 Bolt size - 7/16 hole	234-101
19	1	PW 1/2 Bolt size - 9 /16 hole	234-121
20	1	Hold Down Adj. Bolt 3/8 x 7	212-122
21	1	HHMB 3/8 x 1-1/2 GR 2 - zinc	212-105
22	1	HHMB 3/8 x 4-1/2 GR 8 - zinc	212-119
23	5	3/8 Nylon Insert Locknut	214-538
24	1	Hold Down Chain Assy (Float)	8-9611
25	1	Hold Down Assy, complete without rack	8-9478
26	1	HHMB 3/8 x 1-1/2 GR 2 — Zinc	212-105
27	1	HHMB 3/8 x 4-1/2 GR 8 — Zinc	212-119
28	5	3/8 Nylon Insert Locknut	214-538
29A	1	Hold Down Chain Assy. (Float) — WS/WL 600	8-9611
29B	1	Hold Down Chain Assy. (Float) — WS/WL 800 and WS/WL 1000	8-9612
30	1	HHMB 3/8 — 16 x 3 UNC	212-110
31	1	Roller, Cam	156-332

PARTS LIST, continued

WL SERIES DOCK LEVELER

Fig. 30

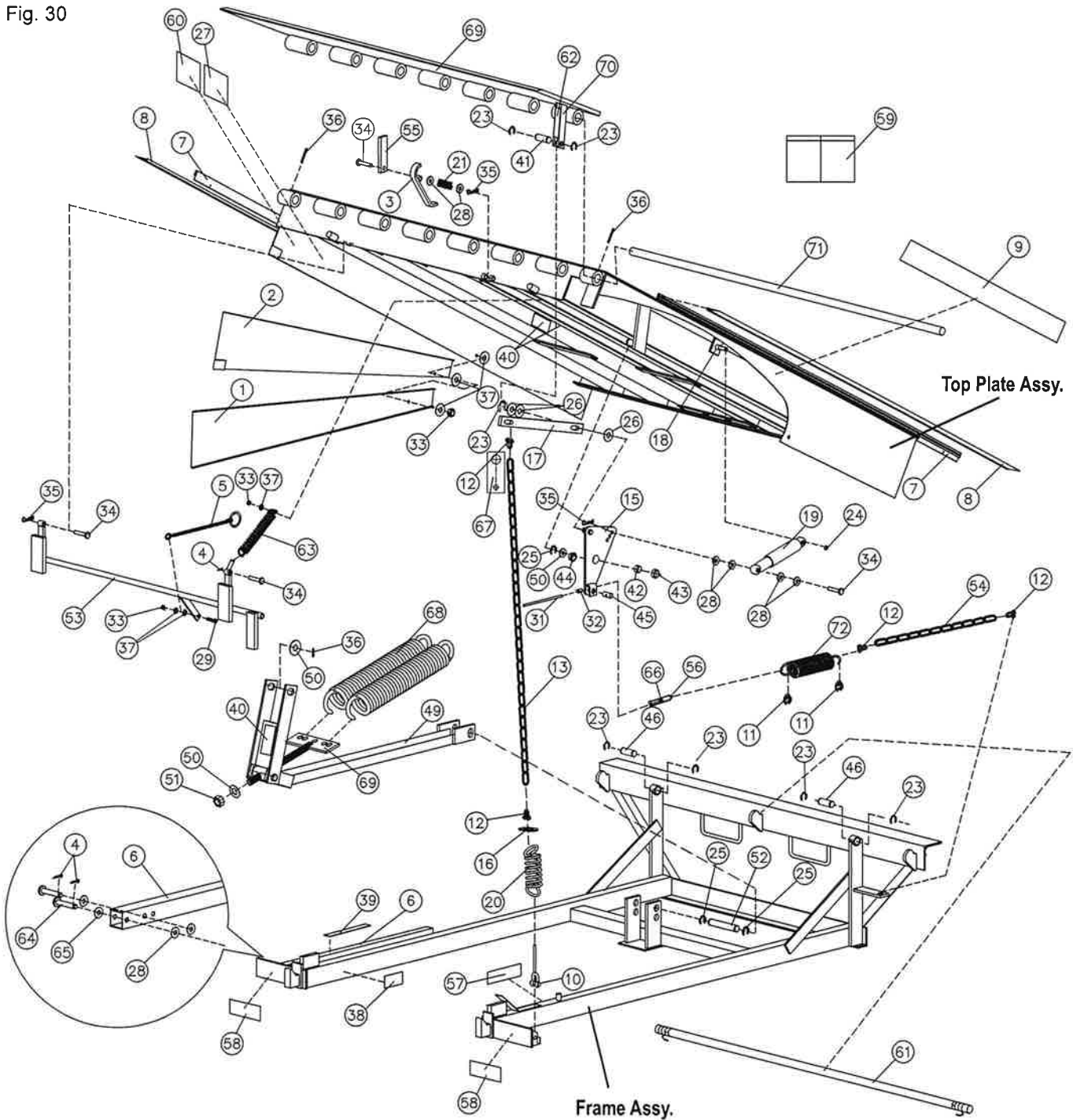

PARTS LIST, continued

WL AND WS SERIES DOCK LEVELERS

Item	Qty.	Part Description	Part Number		
			CM600 WS600 WL600	CM800 WS800 WL800	CM1000 WS1000 WL1000
1	1	Toe Guard, 2nd stage, left (when specified)	586-1659	586-0440	586-1045
	1	Toe Guard, 2nd stage, right (when specified)	586-1660	586-0441	586-1044
2	1	Toe Guard, 1st stage, left (when specified)	586-1657	586-0438	586-1043
	1	Toe Guard, 1st stage, right (when specified)	586-1658	586-0439	586-1042
3	1	Pusher Assy. (for safety legs)	3-4666	3-4666	3-4666
	1	Pusher Assy. (below dock control)	3-4799	3-4799	3-4799
4	2	Cotter Pin 1/8 x 3/4	231-341	231-341	231-341
5	1	Chain Assy. B.D.C. (Below Dock Control)	8-9610	8-9610	8-9610
6	1	Maintenance Post 600 - CP	586-2966	586-2966	586-2966
7	2	Weather Seal Mounting Strip (with Rubber Seal Only)	328-897	328-898	328-898
8	2	Weather Seal - Narrow Projection - Rubber (1-1/4")	152-324(5ft)	152-324(7ft)	152-324(7ft)
	2	Weather Seal - Wide Projection - Rubber (1-3/4")	152-325(5ft)	152-325(7ft)	152-325(7ft)
	2	Weather Seal - Narrow Projection - Brush	328-886	328-887	328-888
	2	Weather Seal - Wide Projection - Brush	328-907	328-908	328-909
9	2	Do Not Lift/Trip Warning	138-837	138-837	138-837
10	1	Spring Guide Assy	3-5335	3-5335	3-5335
11	2	Cable Clamp	441-103	441-103	441-103
12	4	Chain Shackle 1/4"	442-800	442-800	442-800
13	1	Chain - Hydra-Shock	586-1954	586-2270	586-2271
14	1	Plain Hex Nut, 3/8" - 16 UNC			
15	1	Bellcrank Weldment - Hydra-Cam - CP	3-3332	3-3332	3-3332
16	1	Chain Stop	341-014	341-014	341-014
17	1	Lip Assist Bar - "HS"	328-685	328-685	328-685
18	1	Hydra-Cam Plate Assy.	8-9043	8-9043	8-9043
19	1	Hydra-Shock	328-729	328-729	328-729
20	1	Extension Spring (D84)	333-029	333-029	333-029
21	1	Compression Spring	333-069	333-069	333-069
22	2	Extension Spring - Latch Bar	333-042	333-042	333-042
23	7	Retaining Ring (5304-75)	236-110	236-110	236-110
24	1	Retaining Ring (5304-50)	236-106	236-106	236-106
25	3	Retaining Ring (5304-100)	236-114	236-114	236-114
26	3	Plain Washer - 3/4 ID x 1/2 OD Hardend	234-143	234-143	234-143

PARTS LIST, continued

WL AND WS SERIES DOCK LEVELERS, continued

Item	Qty.	Part Description	Part Number		
			CM600 WS600 WL600	CM800 WS800 WL800	CM1000 WS1000 WL1000
27	2	Serco Brand Identifier Label	921-185	921-185	921-185
27	2	Kelley Brand Identifier Label	921-186	921-186	921-186
28	6	Plain Washer - 9/16" I.D.	234-121	234-121	234-121
29	1	Hex Bolt - 3/8" - 16 UNC x 1-1/4" lg	212-104	212-104	212-104
30	1	Hex Bolt - 3/8" x 3" lg	212-118	212-118	212-118
31	1	Bolt Rod Assy. - CP	3-4737	3-4737	3-4737
32	1	EL Rod Spacer	586-1999	586-1999	586-1999
33	5	Hex Nut - 3/8" Nylock	214-538	214-538	214-538
34	4	Clevis Pin - 1/2" DIA x 2-3/4" lg	231-502	231-502	231-502
35	4	Hitch Pin Clip	231-503	231-503	231-503
36	3	Spring Pin	231-123	231-123	231-123
37	9	Plain Washer 3/8" Bolt Size - 7/16" Hole	234-101	234-101	234-101
38	2	Warning Label (Entering Pit)	921-070	921-070	921-070
39	1	Warning Label	921-074	921-074	921-074
40	3	Warning Label (Springs)	921-117	921-117	921-117
41	1	Pin - 3/4" Dia x 2-7/8" Gr-Rng	583-0003	583-0003	583-0003
42	1	DU Bushing: 16DU08	821-034	821-034	821-034
43	1	Bellcrank Spacer	586-3031	586-3031	586-3031
44	1	DU Bushing - Flanged: 16FDU08	821-033	821-033	821-033
45	1	EL - Yoke Pin	586-1998	586-1998	586-1998
46	2	Pin - 3/4" Dia	586-1467	586-1467	586-1467v
47	1	Pin - 3/4" Dia x 2-1/18" Gr-Rng	586-0003	586-0003	586-0003
48	1	EL - Latch Bar Return Spring	333-045	333-045	333-045
49	1	Lift Arm Assy.	3-5265	3-5265	3-5265
50	3	Plain Washer - 1" Bolt Size - 1-1/16" Hole Size	234-161	234-161	234-161
51	1	Hex Nut 1" - 8	214-241	214-341	214-341
52	1	Pin - 1" Dia 5-1/2" Gr-Rng	586-1070	586-1070	586-1070
53	1	Upper Safety Leg Assy.	3-4667	3-4667	3-4667
54	1	Rear Chain	586-3016	586-3020	586-3120
55	1	Lip Plate Maint. Bar	586-2969	586-2969	586-2969

PARTS LIST, continued

WL AND WS SERIES DOCK LEVELERS, continued

Item	Qty.	Part Description	Part Number		
			CM600 WS600 WL600	CM800 WS800 WL800	CM1000 WS1000 WL1000
56	1	Spring Adjusting Loop	586-3009	586-3009	586-3009
57	1	ID Tag	6001800	6001800	6001800
58	2	Serco Name Plate	824-002	824-002	824-002
58	2	Kelley Name Plate	921-140	921-140	921-140
59	1	Placard	6001946	6001946	6001946
60	2	User Warning Label	6001044	6001044	6001044
61	1	Rear WeatherSeal CP 6ft.	3-4701	3-4701	3-4701
	1	Rear WeatherSeal CP 6.5ft.	3-4702	3-4702	3-4702
	1	Rear WeatherSeal CP 7ft.	3-4703	3-4703	3-4703
62	1	S/L Guide Arm - CP	586-2959	586-2959	586-2959
63	1	Safety Leg Spring	333-055	333-055	333-055
64	4	Clevis Pin 1/2" DIA x 2-1/4 lg	231-506	231-506	231-506
65	4	SAE - 1/2" Washer	234-260	234-260	234-260
66	1	SQ. Nut 3/8-16 UNC Plain	214-826	214-826	214-826
67	1	Latch Tab Hydra	586-1384	586-1384	586-1384

DOCK LEVELER — 600

Item	Qty.	Part Description	Capacity			
			30,000	35,000	40,000	45,000
68	3	Main Spring, Extension - 6 ft x 16 in	333-049	333-049	333-049	333-049
		Main Spring, Extension - 6 ft x 18 in	333-054*	333-054*	333-054*	333-054*
		Main Spring, Extension - 6 ft x 20 in	333-054*	333-054*	333-054*	333-054*
68	2	Main Spring, Extension - 6.5 ft x 16 in	333-054	333-054	333-054	333-054
		Main Spring, Extension - 6.5 ft x 18 in	333-054	333-054	333-054	333-054
		Main Spring, Extension - 6.5 ft x 20 in	333-054	333-054	333-054	333-054
68	2	Main Spring, Extension - 7 ft x 16 in	333-054	333-054	333-054	333-054
		Main Spring, Extension - 7 ft x 18 in	333-054	333-054	333-054	333-054
		Main Spring, Extension - 7 ft x 20 in	333-054	333-054	333-054	333-054
69	1	Main Spring, Support Assembly	3-5073	3-5073	3-5073	3-5073

* Quantity — 2

PARTS LIST, continued

DOCK LEVELER — 800

Item	Qty.	Part Description	Capacity			
			30,000	35,000	40,000	45,000
68	2	Main Spring, Extension - 6 ft x 16 in	333-054	333-054	333-054	333-049†
	2	Main Spring, Extension - 6 ft x 18 in	333-054	333-054	333-054	333-054
	2	Main Spring, Extension - 6 ft x 20 in	333-054	333-054	333-054	333-054
	1	Main Spring, Extension - 6 ft x 20 in	—	—	333-049	333-049
68	2	Main Spring, Extension - 6.5 ft x 16 in	333-054	333-054	333-054	333-054
	1	Main Spring, Extension - 6.5 ft x 16 in	—	—	333-049	333-049
	2	Main Spring, Extension - 6.5 ft x 18 in	333-054	333-054	333-054	333-054
	1	Main Spring, Extension - 6.5 ft x 18 in	—	—	333-049	333-049
	2	Main Spring, Extension - 6.5 ft x 20 in	333-054	333-054	333-054	333-054
	1	Main Spring, Extension - 6.5 ft x 20 in	—	—	333-049	333-049
68	2	Main Spring, Extension - 7 ft x 16 in	333-054	333-054	333-054	333-054
	1	Main Spring, Extension - 7 ft x 16 in	—	—	333-049	333-049
	2	Main Spring, Extension - 7 ft x 18 in	333-054	333-054	333-054	333-054
	1	Main Spring, Extension - 7 ft x 18 in	—	—	333-049	333-049
	2	Main Spring, Extension - 7 ft x 20 in	333-054	333-054	333-054	333-054
	1	Main Spring, Extension - 7 ft x 20 in	—	—	333-049	333-049
69	1	Main Spring, Support Assembly	3-5073	3-5073	3-5073	3-5073

DOCK LEVELER — 1000

68	2	Main Spring, Extension - 6 ft x 16 in	333-054	333-054	333-054†	333-054†
	1		333-049	333-049	333-049	333-049
	2	Main Spring, Extension - 6 ft x 18 in	333-054	333-054	333-054†	333-054†
1	333-049		333-049	—	—	
68	2	Main Spring, Extension - 6 ft x 20 in	333-054	333-054	333-054†	333-054†
	1		333-049	333-049	—	—
	2	Main Spring, Extension - 6.5 ft x 16 in	333-054	333-054	333-054†	333-054†
1	333-049		333-049	—	—	
68	2	Main Spring, Extension - 6.5 ft x 18 in	333-054	333-054	333-054†	333-054†
	1		333-049	333-049	—	—
	2	Main Spring, Extension - 6.5 ft x 20 in	333-054	333-054	333-054†	333-054†
1	333-049		333-049	333-049	333-049	
68	3	Main Spring, Extension - 7 ft x 16 in	333-054	333-054	333-045‡	333-045‡
	1		—	—	—	—
	3	Main Spring, Extension - 7 ft x 18 in	333-054	333-054	333-045‡	333-045‡
1	—		—	—	—	
68	3	Main Spring, Extension - 7 ft x 20 in	333-054	333-054	333-045‡	333-045‡
	1		—	—	—	—
69	?	Main Spring, Support Assembly	3-5254	3-5254	3-5254	3-5254

* Quantity — 2; †Quantity — 3; ‡Quantity — 4

PARTS LIST, continued

DOCK LEVELER — ALL

Item	Qty.	Part Description	Capacity			
			30,000	35,000	40,000	45,000
70	1	Lip Assembly - "L" - 6 ft x 16 in	3-0845	3-0848	3-0851	3-0854
		Lip Assembly - "L" - 6 ft x 18 in	3-0846	3-0849	3-0852	3-0855
		Lip Assembly - "L" - 6 ft x 20 in	3-0847	3-0850	3-0853	3-0856
	1	Lip Assembly - "L" - 6.5 ft x 16 in	3-0863	3-0866	3-0869	3-0872
		Lip Assembly - "L" - 6.5 ft x 18 in	3-0864	3-0867	3-0870	3-0873
		Lip Assembly - "L" - 6.5 ft x 20 in	3-0865	3-0868	3-0871	3-0874
	1	Lip Assembly - "L" - 7 ft x 16 in	3-0881	3-0884	3-0887	3-0890
		Lip Assembly - "L" - 7 ft x 18 in	3-0882	3-0885	3-0888	3-0891
		Lip Assembly - "L" - 7 ft x 20 in	3-0883	3-0886	3-0889	3-0892
71	2	Latch Assist Arm - 1-3/4" Tube - "L"	586-2272	586-2272	—	—
	2	Latch Assist Arm - 2-3/8" Tube - "L"	—	—	586-2638	586-2638
72	1	Lip Hinge Pin - 6 ft wide	586-0017	586-0017	586-0287	586-0287
	1	Lip Hinge Pin - 6.5 ft wide	586-1494	586-1494	586-1495	586-1495
	1	Lip Hinge Pin - 7 ft wide	586-0201	586-0201	586-0392	586-0392
73	1	Extension Spring, Lip - 6 ft x 16 in	333-043	333-043	333-043	333-043
	1	Extension Spring, Lip - 6 ft x 18 in	333-044	333-044	333-043	333-043
	1	Extension Spring, Lip - 6 ft x 20 in	333-044	333-044	333-044	333-044
	1	Extension Spring, Lip - 6.5 ft x 16 in	333-043	333-043	333-043	333-043
	1	Extension Spring, Lip - 6.5 ft x 18 in	333-044	333-044	333-044	333-044
	1	Extension Spring, Lip - 6.5 ft x 20 in	333-044	333-044	333-044	333-044
	1	Extension Spring, Lip - 7 ft x 16 in	333-043	333-043	333-043	333-043
	1	Extension Spring, Lip - 7 ft x 18 in	333-044	333-044	333-044	333-044
	1	Extension Spring, Lip - 7 ft x 20 in	333-044	333-044	333-044	333-044