

Lever on Rose Fitting Instructions

1. Mark out centre hole **A**, then fixing holes **B** at 38mm centres using a bradawl.
2. Using a 20mm diameter bit, drill centre hole **A** at the centre location.
 - i. For bolt-through fixings, use a 5mm diameter bit and drill fixing holes **B1** and **B2** at 38mm centres as shown.
 - ii. For face fixings, drill pilot holes **B** to a depth of 5mm using a 2mm diameter drill bit.
3. Insert the spindle into one of the levers and securely fix the grub screw, ensuring enough spindle is free to pass through the door and to be secured in the opposing lever.
4. Place the lever onto the door so the spindle passes through the latch/lock follower and line up the holes on the rose with those pre-drilled in the door.
5. Place the second lever onto the opposite side of the door.
 - i. For bolt-through fixings, use both bolts and evenly hand tighten so each lever is secured firmly against the surface of the door.
 - ii. For face fixings, evenly hand tighten up the four screws on one side of the door before moving onto the opposite side.
6. Tighten up the grub screw on opposite lever and recheck all fixings are secure. If the levers do not operate freely, check alignment of all components.
7. Place and screw on both outer rose covers.

Bolt-Through Drilling

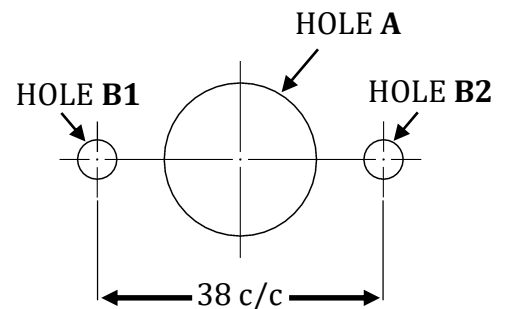

Face Fix Drilling

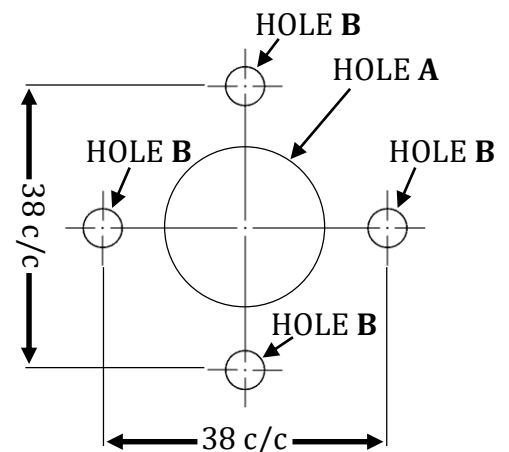

DRAWINGS NOT TO SCALE