

### Lever on Backplate Fitting Instructions

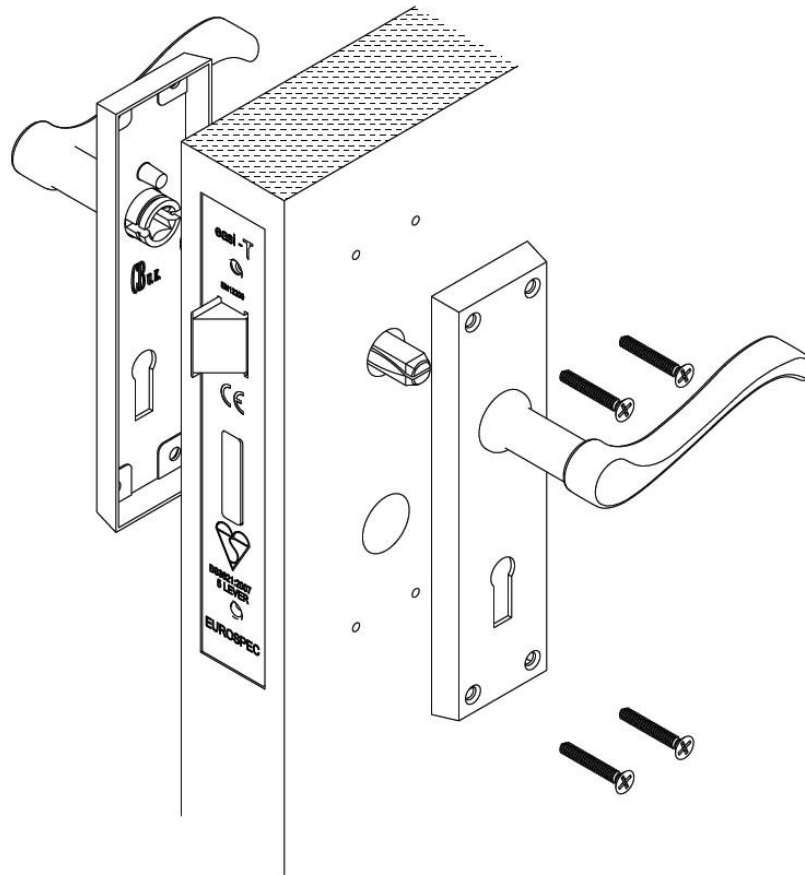

1. Locate the spindle through the square hole in the latch or lock and place the backplates onto the spindle each side of the door.
2. Mark screw holes with a bradawl.
3. Remove backplates and spindle.
4. Drill pilot holes for woodscrews.
5. Fit backplate locating spindle through the square hole in the latch/ lock follower ensuring enough projection of spindle on either side.
6. Tighten grub screws where applicable to secure spindle.
7. Screw wood screws in place when aligned.
8. Ensure door is fitted with correct mortice lock with 57mm centres.