

Congratulations! You're just a few steps away from giving your little one the boost they need to explore their creativity, engage in everyday activities + gain autonomy in their learning journey.

1. On a flat surface, take **Leg (1)** and using 6 bolts (**A**), insert into pre-drilled holes shown on diagram to right.
2. Slot the **Upper Rear Support (3)** into the bolts and fasten with the 4mm Hex key provided. Tighten the bolt until the head touches the wood, and then turn once more to secure.
3. Repeat process with **Lower Rear Support and Step (4)**.
4. Take the other **Leg (2)** and insert the other 6 bolts (**A**) and line up with holes on supports, and screw in.
5. Install the **Platform (5)** by sliding into the correct channel for your child's height. (Your child's belly button should be at counter height or lower.) Secure using bolts (**B**) and tighten using the 4mm hex key, as above.
6. Take the **Leather Strap (6)** with logo facing outwards and place the 4 binding screws (**C**) into each of the pre-punched holes. Insert the binding barrel (**D**) into the holes from the inside and starting on one side, slot both screws into their barrels and tighten until snug. Repeat on the other side.

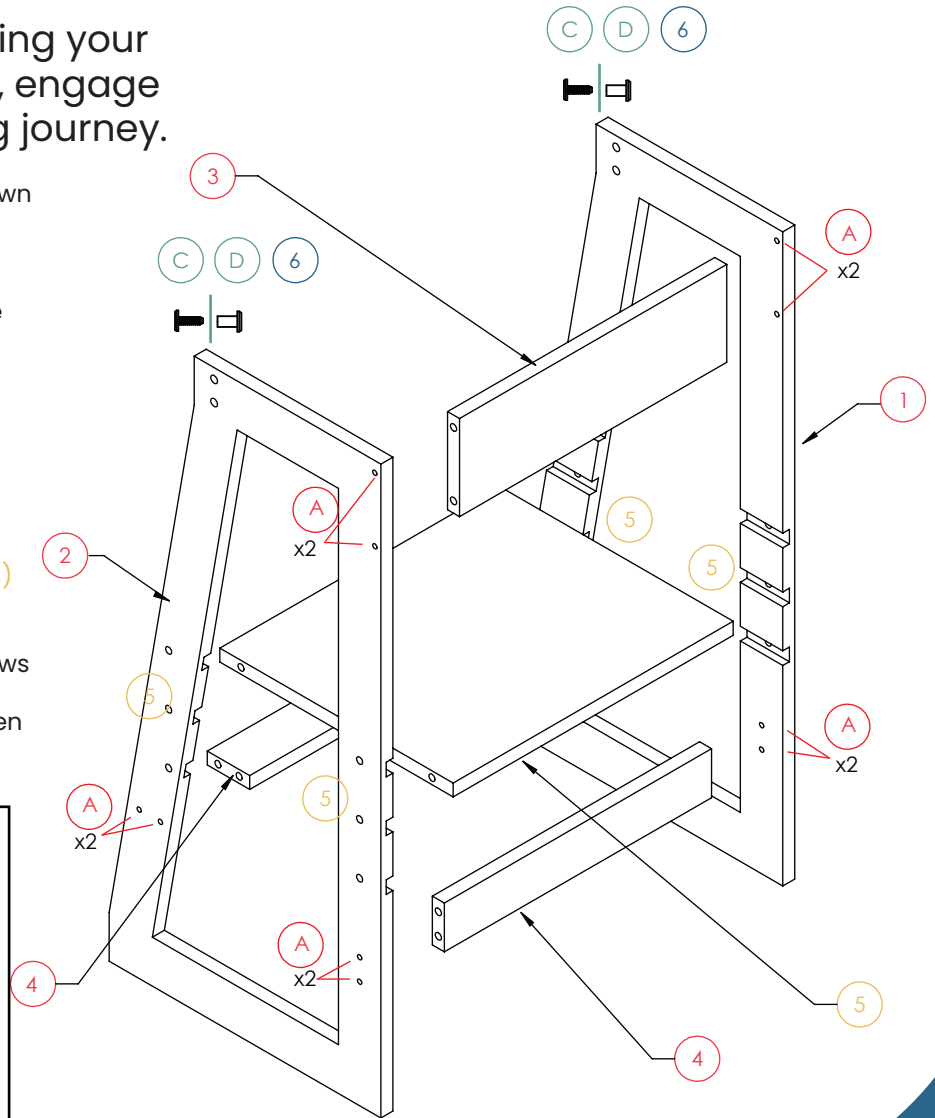

PARTS LIST

The parts list includes the following items:

- Platform (5)
- Upper Rear Support (3)
- Lower Rear Support and Step (4) x2
- Legs (1 and 2)
- Leather Strap (6)
- Bolts (A) x12
- Bolts (B) x4
- Binding Screws (C) x4
- Binding Barrels (D) x4
- 4mm Hex Key

* Not to scale

Use

Toddler Towers are only to be used under close, adult supervision. Children should not use the Toddler Tower unattended.

Ensure Toddler Tower is placed against a counter or solid surface and is out of reach of sharp, hot or dangerous items and with the leather strap facing outwards.

Toddler Towers are meant for use on level surfaces only. Avoid using them on uneven surfaces such as carpet or grass.

Do not climb or swing from the sides of the Toddler Tower, or let your child rock either side to side or back and forth - which may result in tipping.

Toddler Towers are designed for children 2 - 6 years old, however customers have used them for their children in a wider age range based on height, development and motor skills.

Our Toddler Tower will raise your child up to better engage with the work around them. Toddler Towers can be used for a variety of activities from helping the kitchen, working on arts and crafts, keeping up on general hygiene in the bathroom and much more.

Toddler Tower Use and Care

Platform Adjustment

Our Toddler Tower is designed to grow with your little one and has an adjustable platform with heights of 12", 15" and 18". The platform is secured in the grooves with four 4mm Hex screws.

To adjust, simply take the Hex key (included) and remove all 4 screws and slide the platform forward and out.

Slide the platform into the new height and line up the bolt holes on the platform with the holes in the side. The platform should always be flush at the rear.

Place the bolts through the side holes and into the platform holes. Secure by tightening the bolts with the hex key so that the screw-head is flush with the side of the Toddler Tower. Do not over tighten.

Care

Wood - We recommend using a mild, wood-specific cleaner to care for the frames. Our finishes are considered water-resistant, but not waterproof. We recommend that the surfaces are kept dry at most times. The surface can get wet as long as it is dried off in a reasonable time. Avoid direct light and heat sources and setting anything hot or damp on the wood.

Leather - As a natural material, each piece of leather is unique in its color and texture. The leather ages beautifully with use, and is cleaned simply with a damp cloth.



www.franklinemily.com
hello@franklinemily.com
@franklinandemily
1-877-77-ACORN

Proudly designed and manufactured in the USA

