

Julian Bowen Limited Cosmo Guest Bed

Assembly & Care Instructions

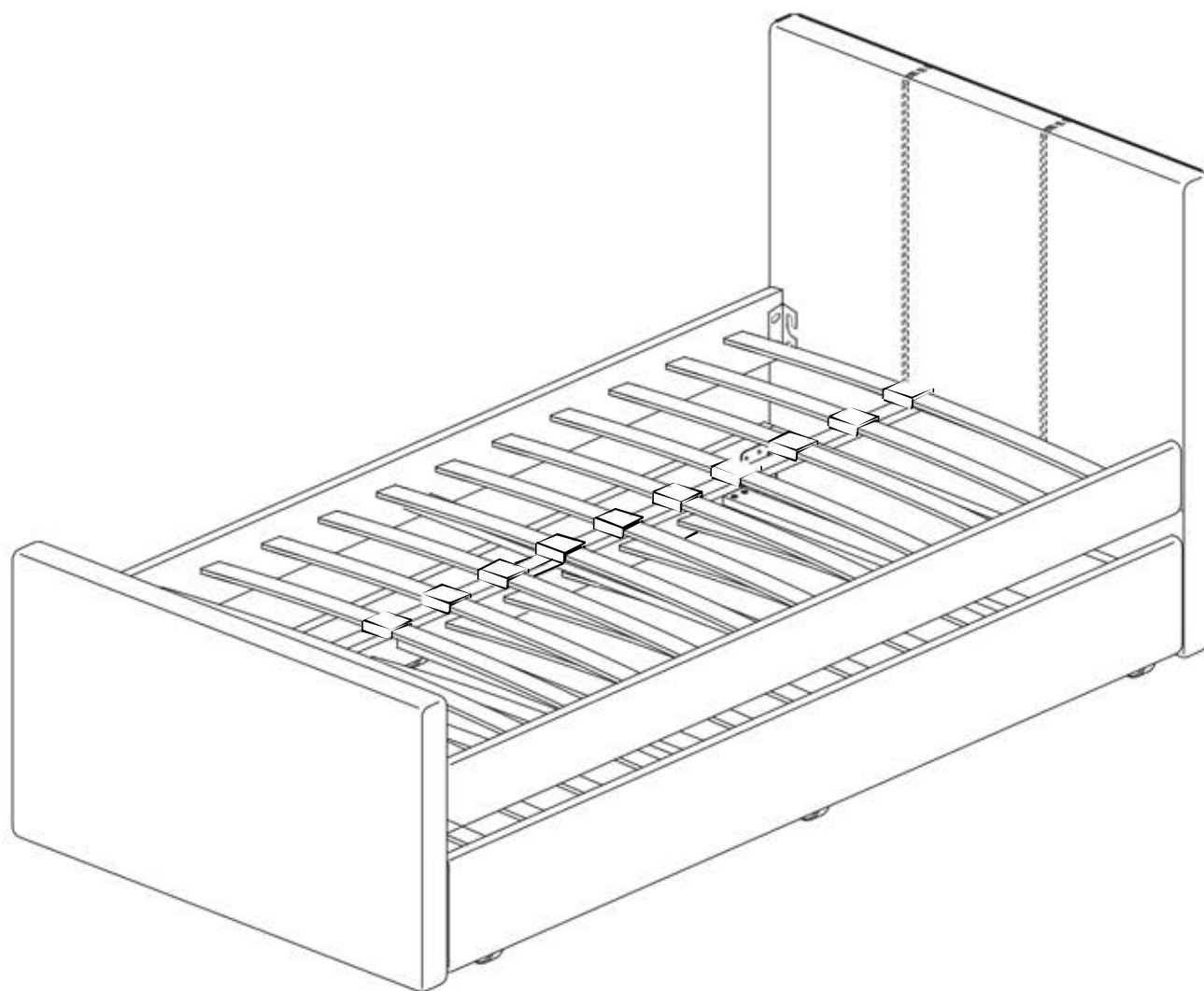



**No Extra
Tools Required**

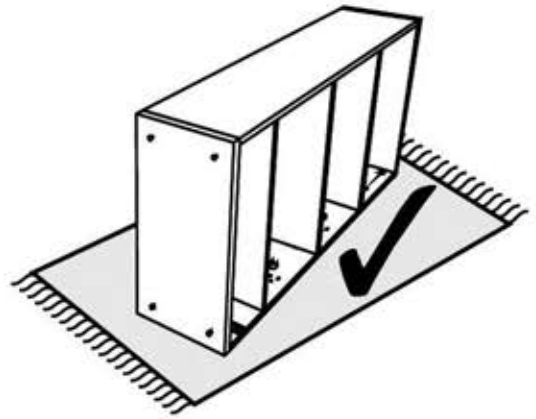
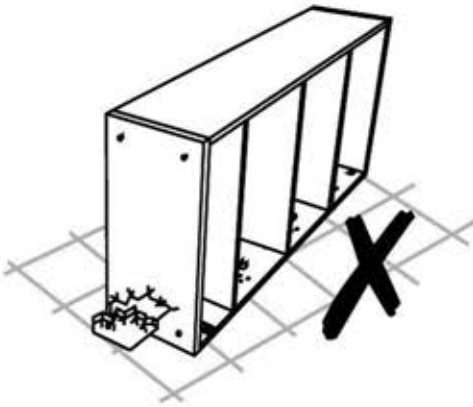
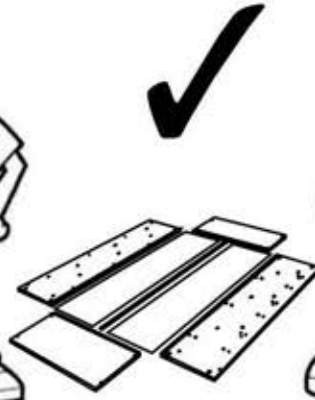
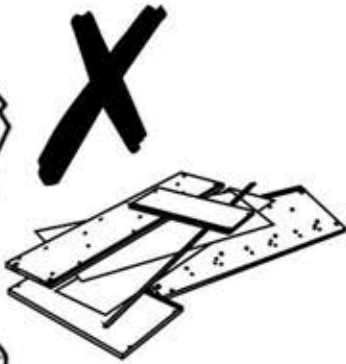
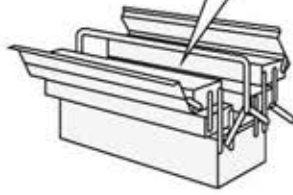

Julian Bowen Limited
+44 (0) 1623 727374

Hardware

A 
Allen Key M8 X 1pc

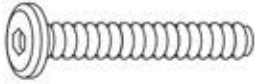
B 
Bolts M8 X 30mm X 32 pcs

C 
Allen Key M6 X 1pc

D 
Foot X 4 pcs

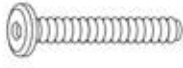
E 
Bolts M6 X 20mm X 16 pcs

F 
Spring Washers X 16 pcs

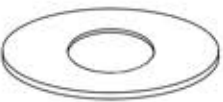
G 
Flat Washer X 32 pcs

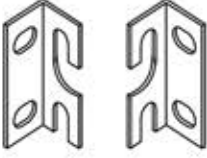
HL  **HR**
Bracket (L & R) X 4 pairs

I 
Wheel X 4

Parts

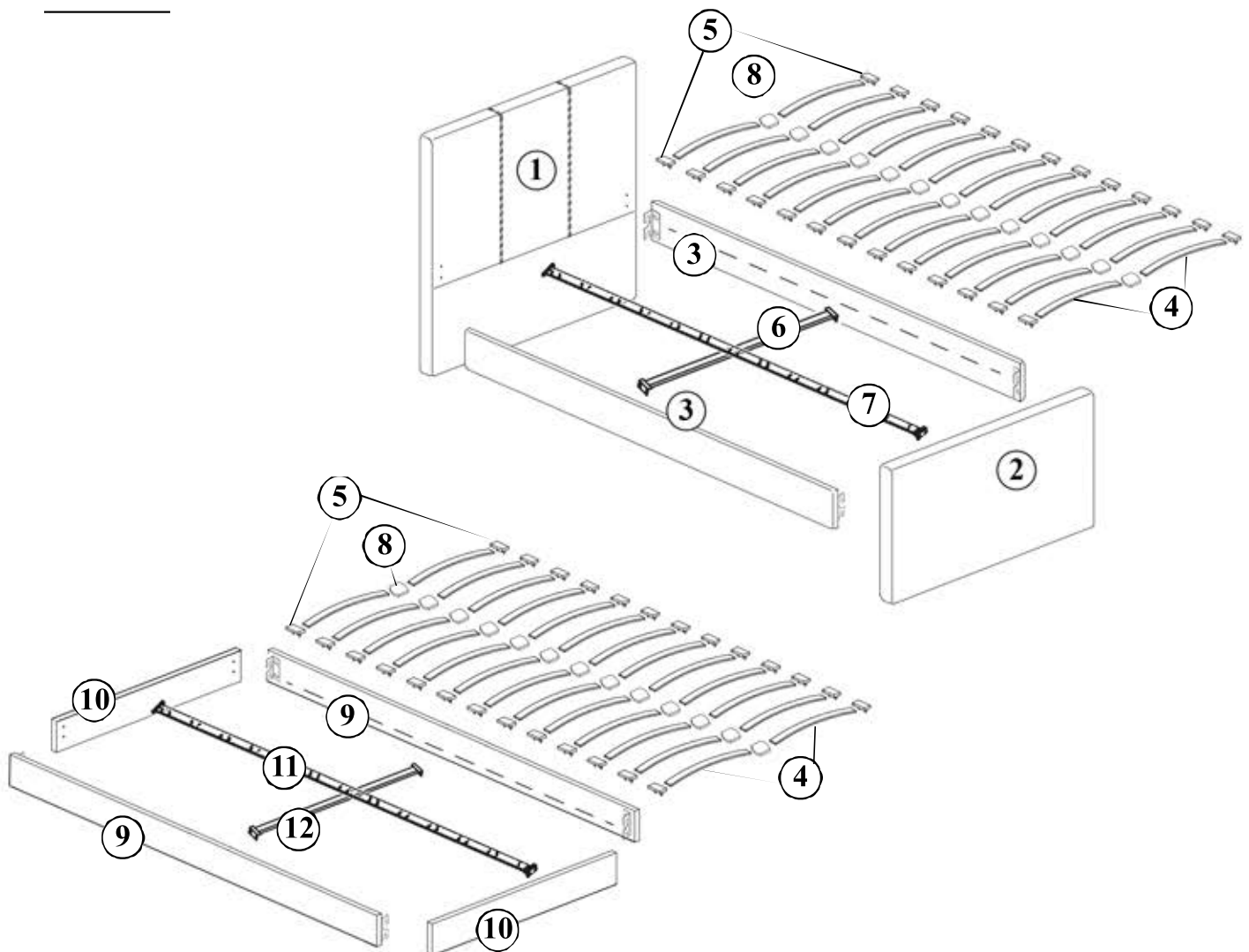

Safety Advice

Please read these instructions carefully before you begin and keep them for future reference.

It would be sensible to lay a sheet or blanket on the floor where you wish to assemble the product, to avoid scratching this product and to protect your floor.

If the product is being used on a wood or laminate floor, we recommend the use of anti-slip pads (available from any good hardware store).

Unpack the product carefully and keep all packaging until you are sure that the product is to your satisfaction.

Inspect and check all of the contents match the parts & hardware list in this document.

We strongly recommend that you keep children away from the work area, as small parts could present a choking hazard.

Do not use any power tools during assembly, as this could cause irreparable damage to your product and will invalidate your warranty.

Please dispose of all packaging in a safe and environmentally friendly way.

HANDY HINT: If you keep the hardware in a bowl during assembly you will be less likely to lose them.

STEP 1



Do Not Use Power Tools

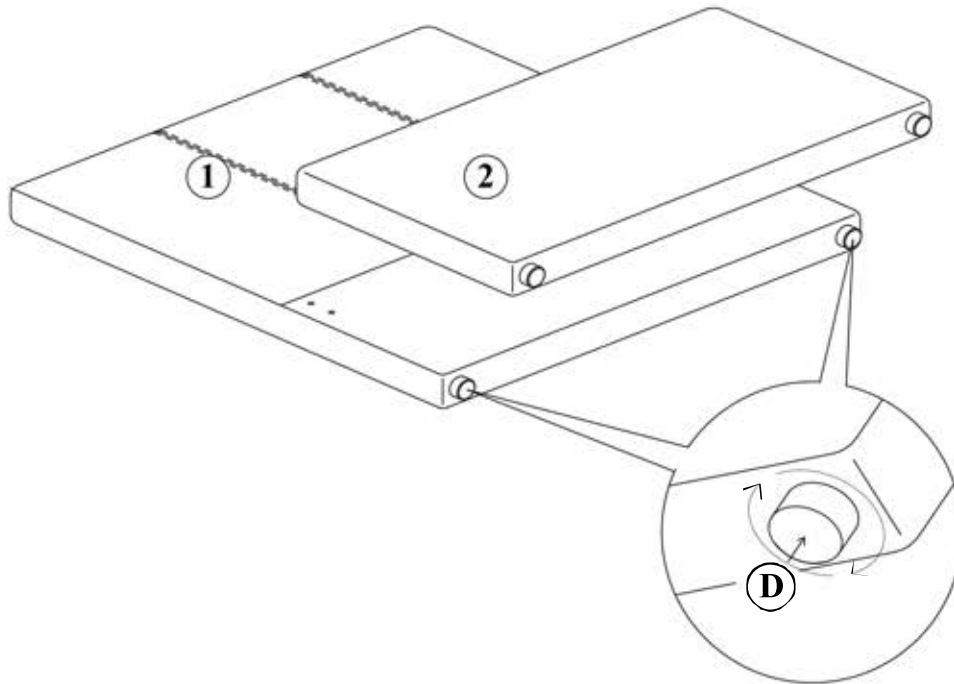

STEP 2

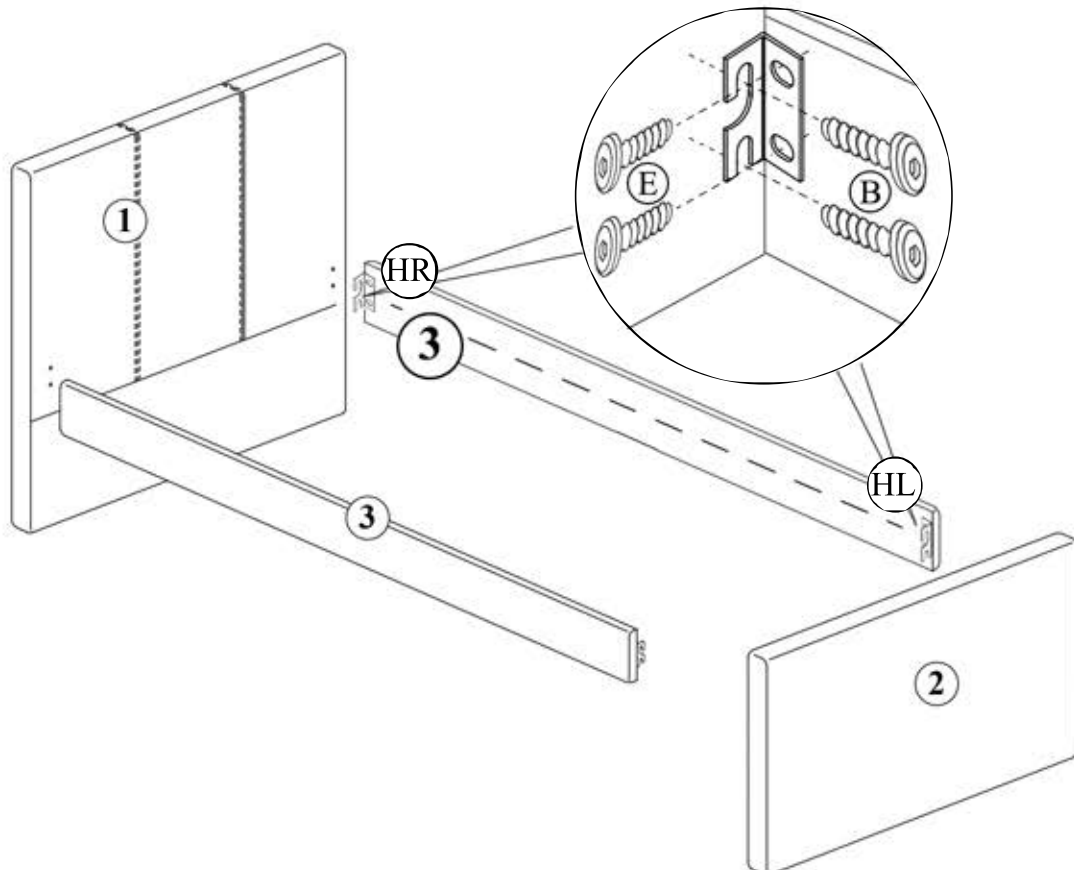

STEP 3



Do Not Use Power Tools

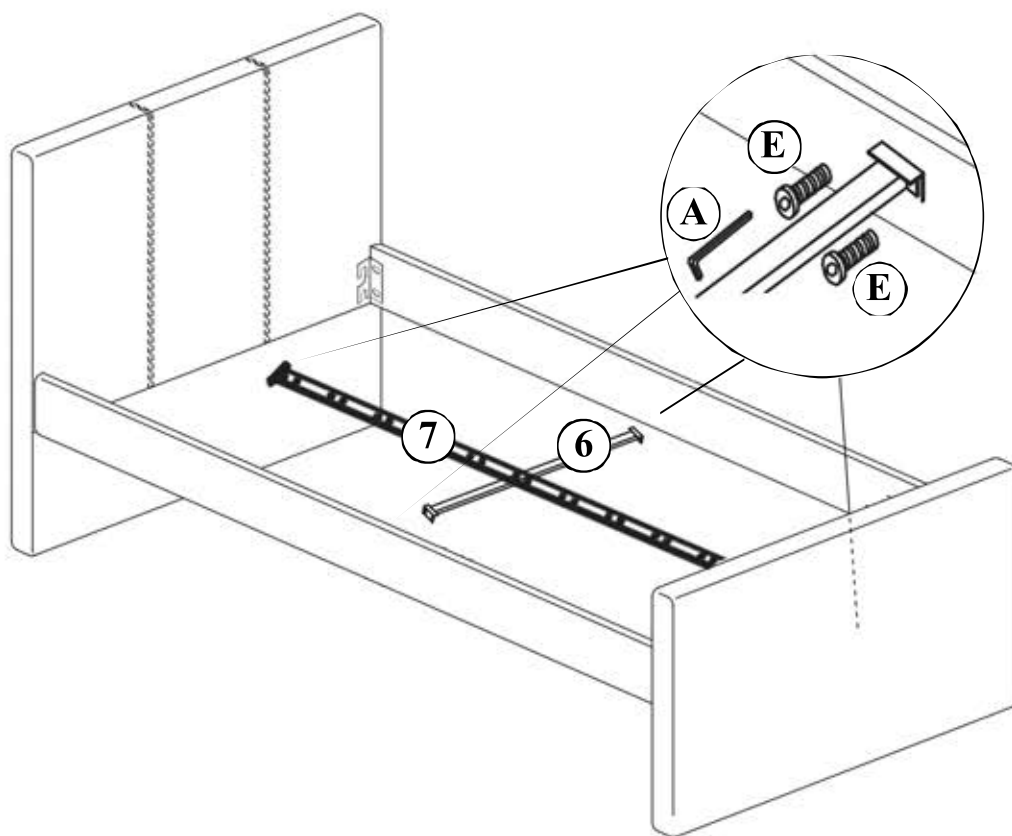

STEP 4

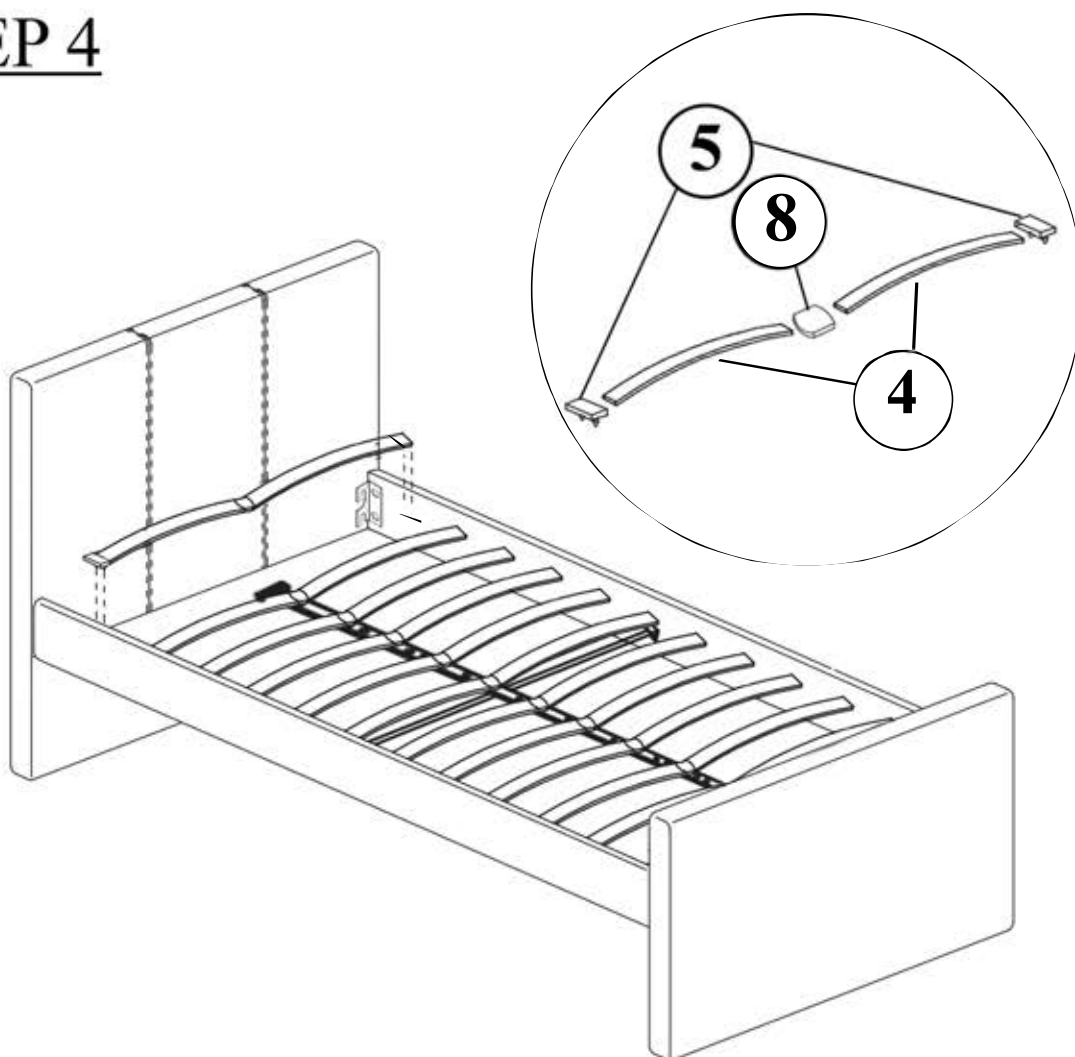

STEP 5

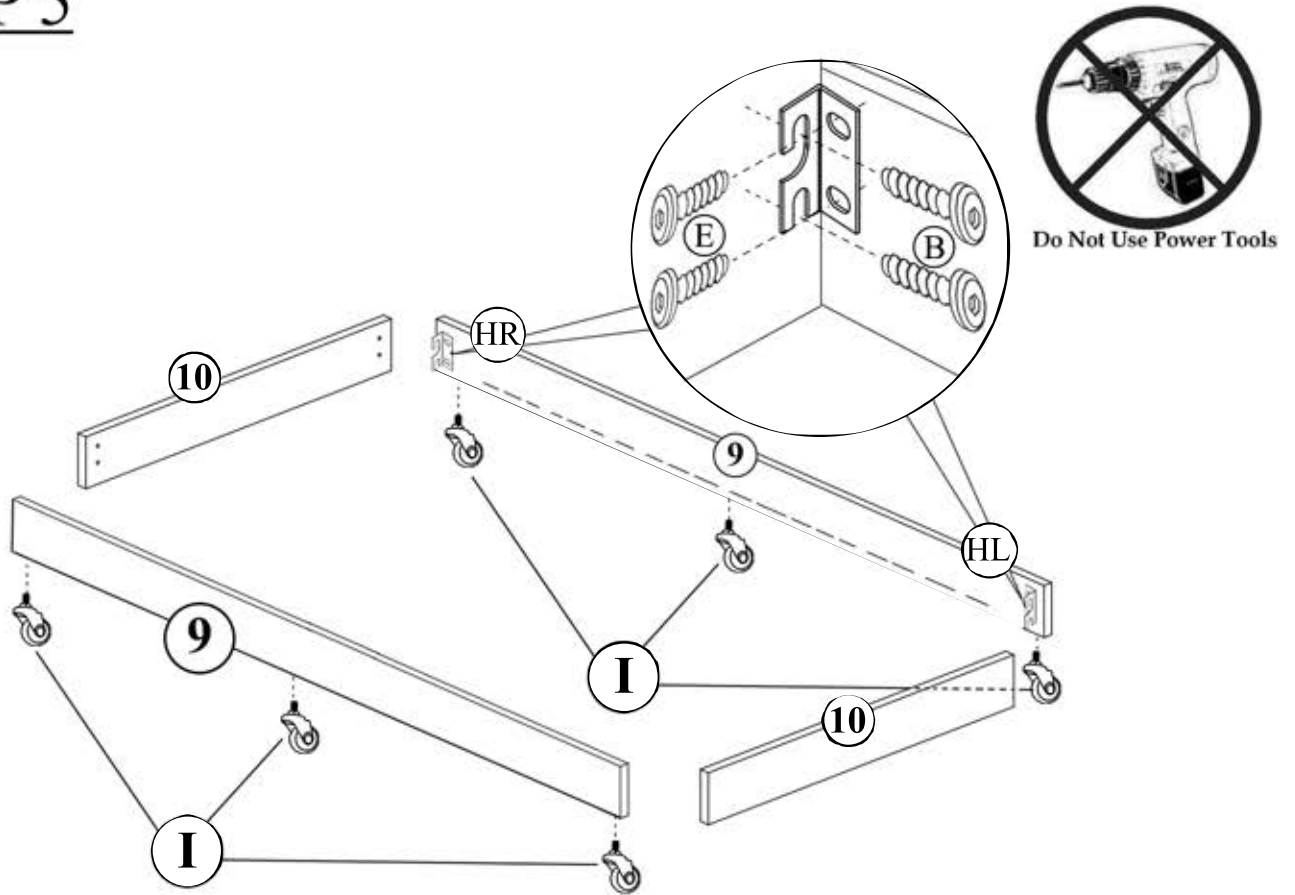

STEP 6

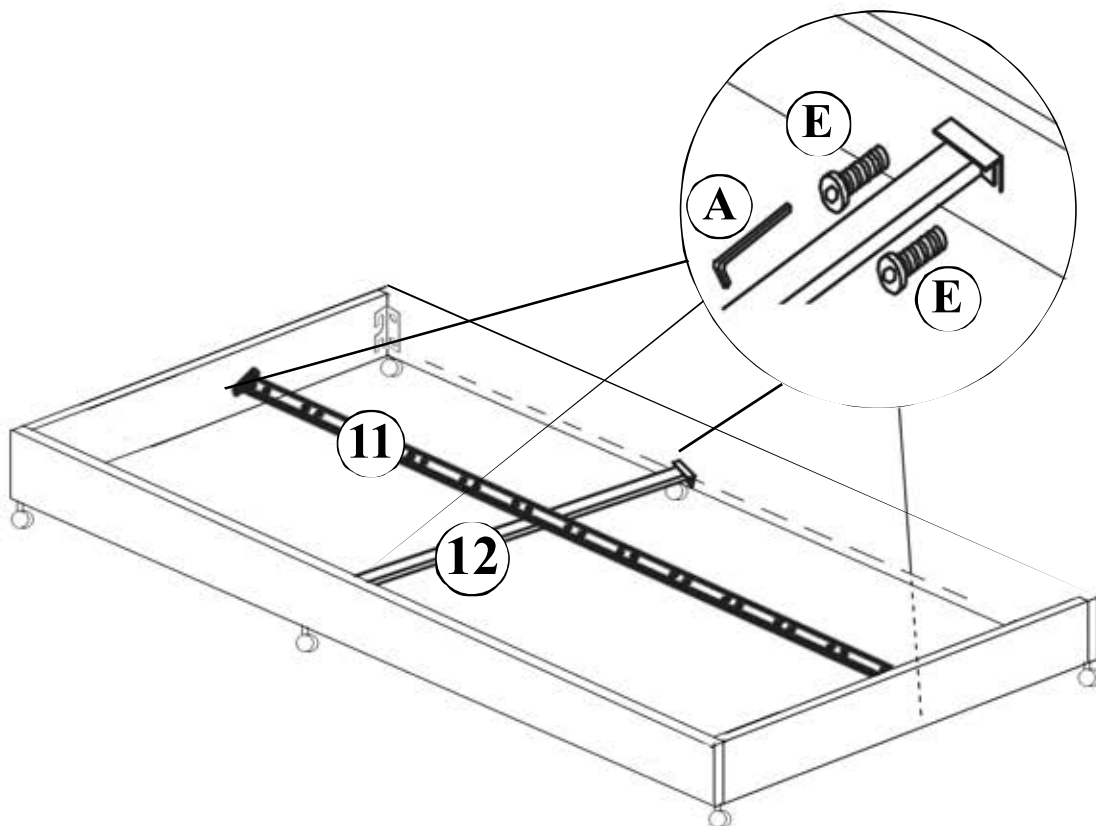

STEP 7

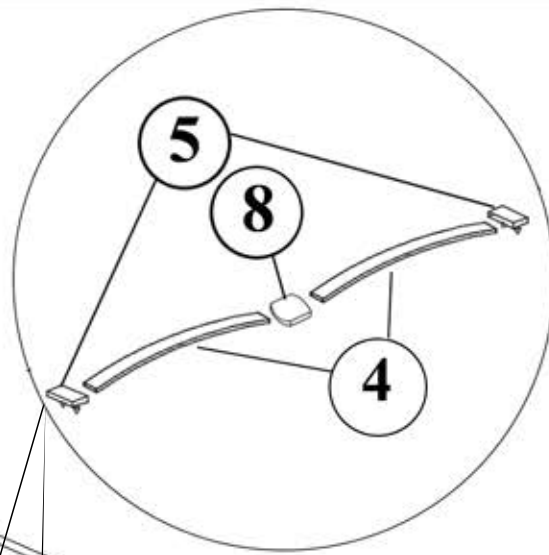

Do Not Use Power Tools

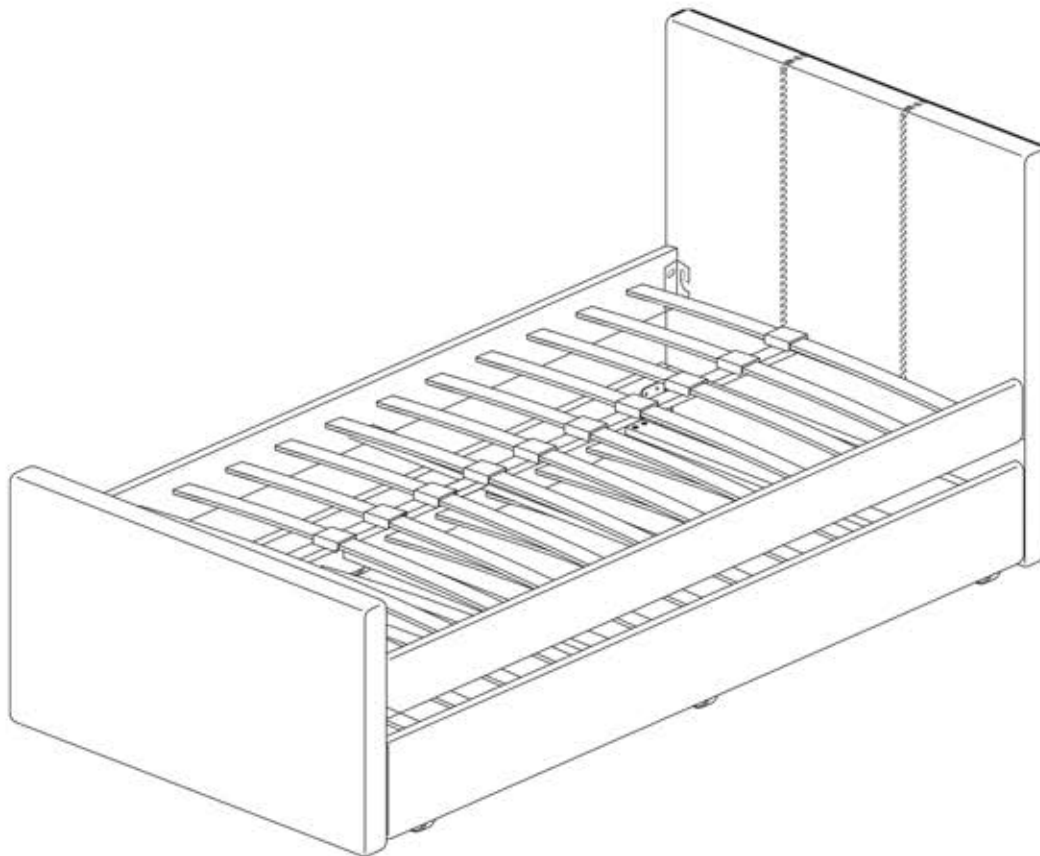
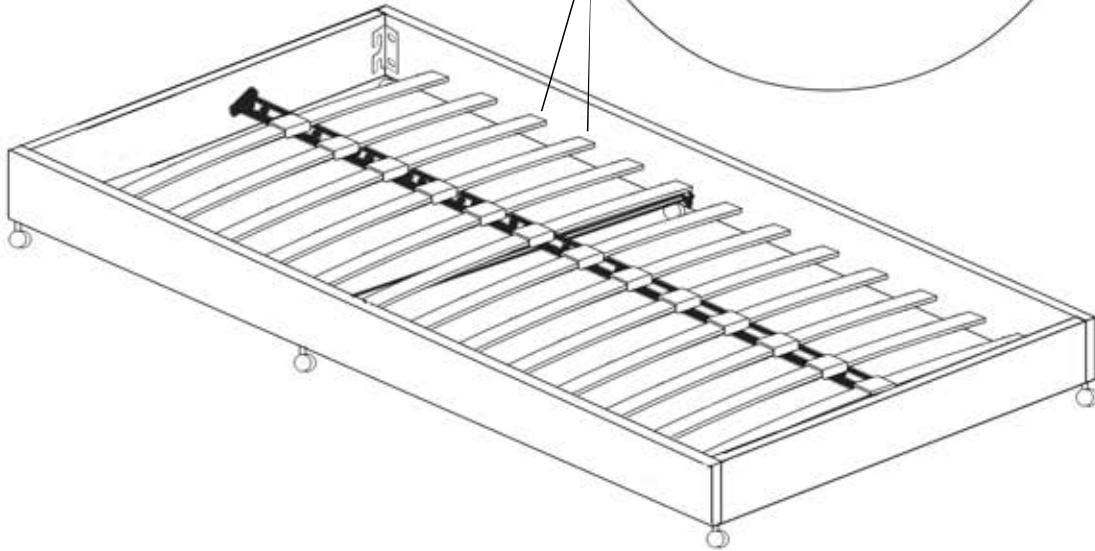

Your Cosmo Guest Bed is ready for use

General Care

Wipe clean with a slightly damp soft cloth.

Avoid the use of all household cleaners and abrasives.

For persistent stains, please seek professional advice.

When moving your furniture, carefully lift into place.

Never drag or push the product across the floor as this will cause damage to the joints and could result in failure to the product that will invalidate the warranty.

Recommendations

Periodical re-tightening of fixings.

Keep out of direct sunlight.

Warning

This unit is heavy. Please use an assistant when lifting.

Notes

We hope you are completely satisfied with this product from the moment it arrives. In the unlikely event that this is not the case, or if you discover any damaged or missing pieces, please call us - quoting the batch number on the label on the back of the headboard - on +44 (0) 1623 727 374.

Julian Bowen Limited

Bentinck House, Park Lane Business Park, Kirkby-in-Ashfield, Notts, NG17 9LE

www.julian-bowen.co.uk