



Trade, DIY, Bulk



T H R U S L I D E
MINIMALIST
W A R D R O B E
DirectDoors.com

For any of our white, walnut and coloured doors we supply the pelmet and frame in white primed MDF for painting but on occasion it may be white paper overlay MDF for painting.

All content and images are copyright protected by DirectDoors.com
Intellectual Property Office Trademark
No: UK00003238454



DOOR CONFIGURATION	DOOR WIDTH OPTIONS	OVERALL WIDTH WITHOUT FRAME	OVERALL WIDTH INCLUDING FRAME	OVERALL HEIGHT WITHOUT FRAME	OVERALL HEIGHT INCLUDING FRAME
2 DOOR	686mm	1352mm	1412mm	1993mm	2053mm
2 DOOR	762mm	1504mm	1564mm	1993mm	2053mm
2 DOOR	838mm	1656mm	1716mm	1993mm	2053mm
3 DOOR	686mm	2018mm	2078mm	1993mm	2053mm
3 DOOR	762mm	2246mm	2306mm	1993mm	2053mm
3 DOOR	838mm	2474mm	2534mm	1993mm	2053mm
4 DOOR	686mm	2704mm	2764mm	1993mm	2053mm
4 DOOR	762mm	3008mm	3068mm	1993mm	2053mm
4 DOOR	838mm	3312mm	3372mm	1993mm	2053mm

IMPORTANT

Please note: You can only assemble these door configurations by using the frame provided. Your warranty will be invalid if other alternatives are used.

All loads are taken by the top track to ensure smooth, light operation and long life.

Prior to installing this doorset, inspect for damage and do not proceed to fit if any noticeable damage or defect is evident. This doorset should be stored in a dry flat location before installation.



Thank you for purchasing one of our Thruslide products, in this PDF we take you step by step on how to assemble and install your new product. We will also go through the list of tools required to do so.

All Thruslide door products are cut to size upon receipt of order and cannot be cancelled afterwards, they are classed as a bespoke item created and manufactured by DirectDoors.com to suit your chosen door dimensions. Please ensure you have a reliable joiner / builder to carry out the following works and ensure that they have a well ventilated area if cutting.

TOOLS REQUIRED

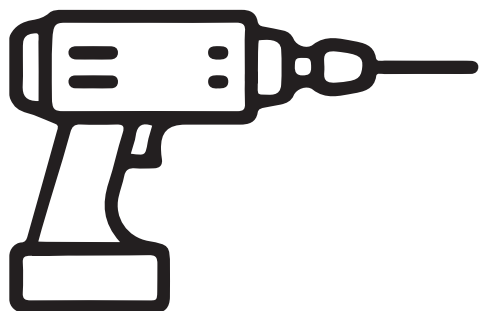

Cordless Power Drill - Drill Bits



3mm Steel Drill Bit (this is required for pilot holes through the MDF frame)



Countersink bit (this is to allow screw heads to go below surface of frame at pilot holes)

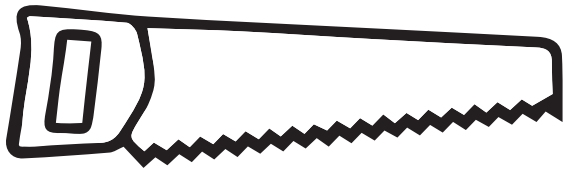

Hand Saw



Tape Measure



Masonry Bit (only required if it's not a timber stud wall you're fixing to)



Spirit Level



Please note that the following materials are supplied with the Thruframes:



Frame screw assembly fixings (this is for fixing the lintel and threshold to the legs)

Please note that the following materials are **NOT** supplied with the Thruframes:



Wall screw fixings and masonry plugs: these are very dependent on whether the wall is "stud" timber frame or brick etc, stud walls do not require masonry plugs



Filler

COMPONENT LIST



2 DOOR SYSTEM

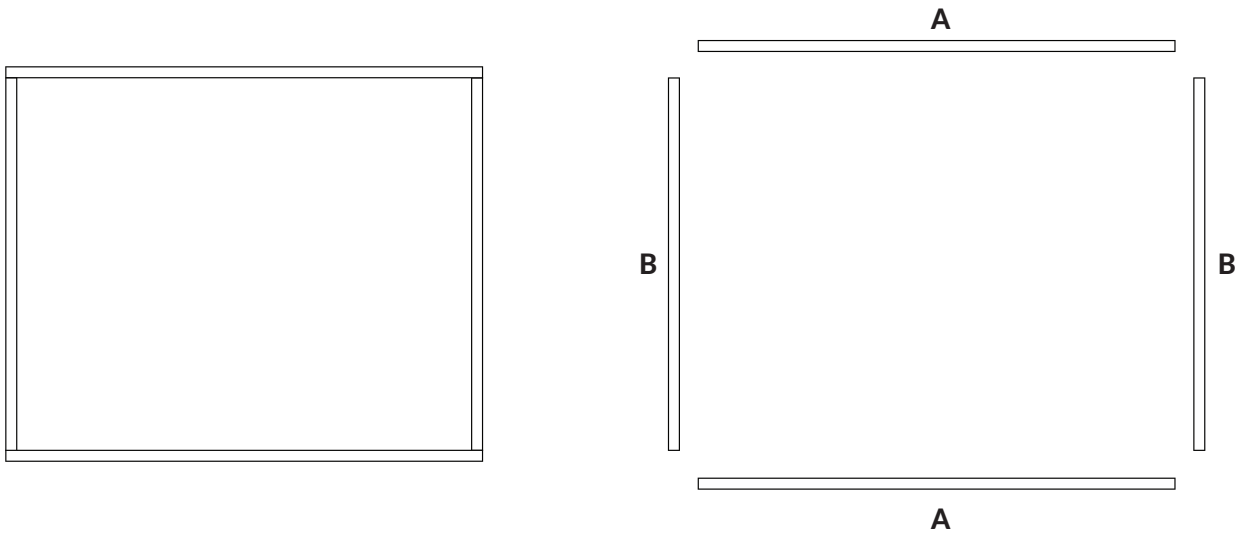

 LINTOL & THRESHOLD PLATE A - x2

 FRAME SIDE/LEG PLATE B - x2

Lintol and Threshold Plate are pre-machined for system tracks.
Lintol and Threshold widths variable depending on the size chosen.

FRAME SCREW  x10

The items below will be delivered from our preferred track supplier:

TOP TRACK  x2

BOTTOM TRACK  x2

ALUMINIUM RAIL  x4

CUP FOR ALUMINIUM RAIL ENDING  x8

ROLLER  x8

FIXING SCREW  x32

ALLEN KEY  x1

Not to scale, dimensions will vary depending on the option chosen.

COMPONENT LIST



3 DOOR SYSTEM

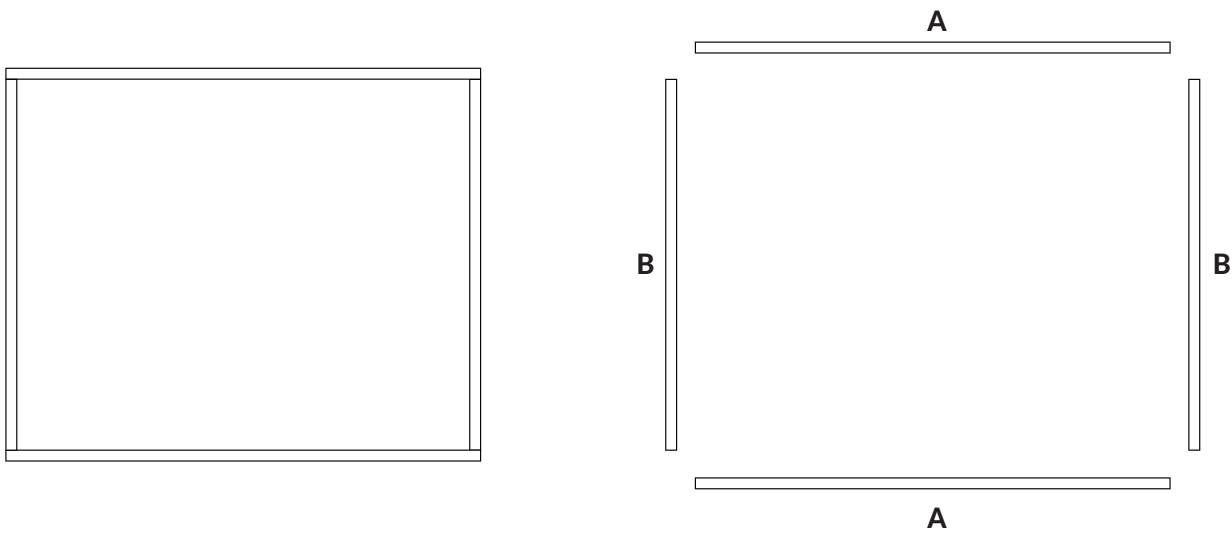

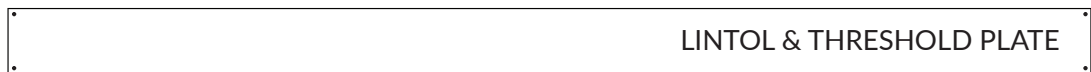
 LINTOL & THRESHOLD PLATE A - x2

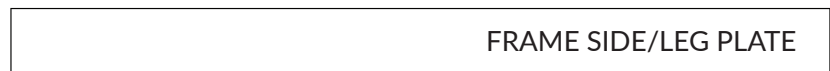
 FRAME SIDE/LEG PLATE B - x2

Lintol and Threshold Plate are pre-machined for system tracks.
Lintol and Threshold widths variable depending on the size chosen.

FRAME SCREW  x10

The items below will be delivered from our preferred track supplier:

TOP TRACK  x2

BOTTOM TRACK  x2

ALUMINIUM RAIL  x4

CUP FOR ALUMINIUM RAIL ENDING  x8

ROLLER  x12

FIXING SCREW  x48

ALLEN KEY  x1

Not to scale, dimensions will vary depending on the option chosen.

COMPONENT LIST



4 DOOR SYSTEM

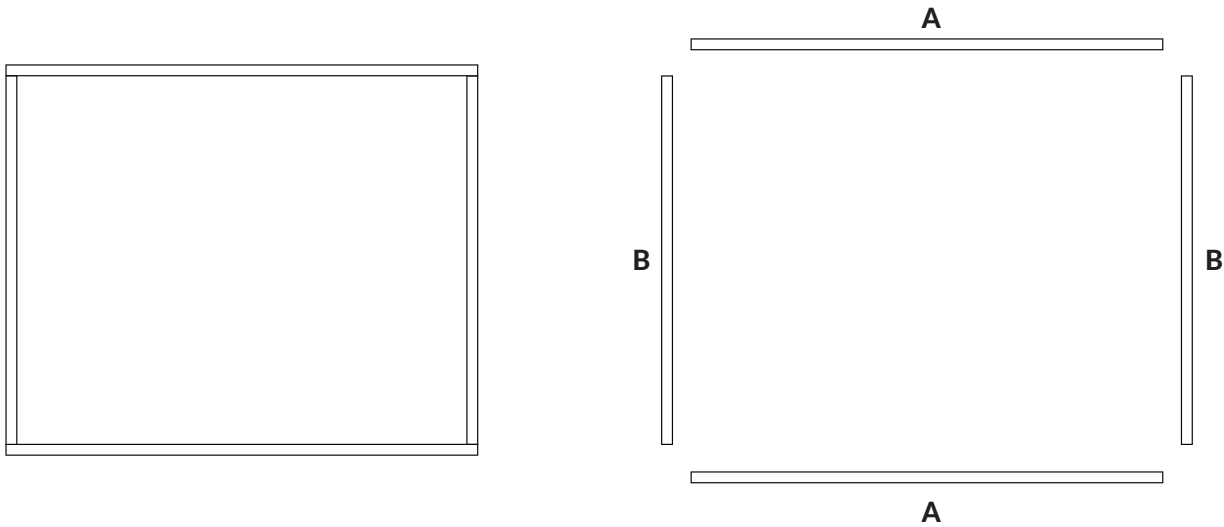

Lintol and Threshold Plate are pre-machined for system tracks.
Lintol and Threshold widths variable depending on the size chosen.

FRAME SCREW  x10

The items below will be delivered from our preferred track supplier:

TOP TRACK  x4

BOTTOM TRACK  x4

ALUMINIUM RAIL  x8

CUP FOR ALUMINIUM RAIL ENDING  x16

ROLLER  x16

FIXING SCREW  x64

ALLEN KEY  x1

Not to scale, dimensions will vary depending on the option chosen.

BUTT

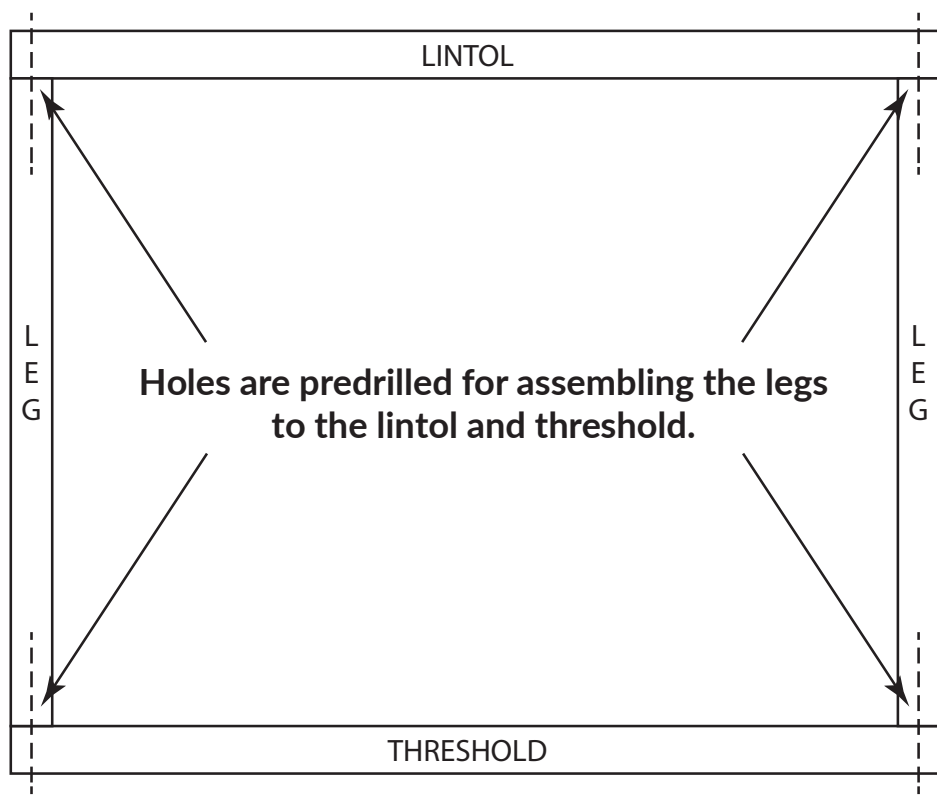

FRONT VIEW

FRAME MUST BE PERFECTLY ALIGNED ON ALL THREE AXIS

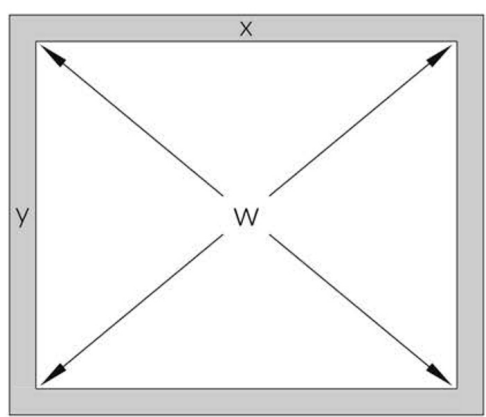

FRONT VIEW

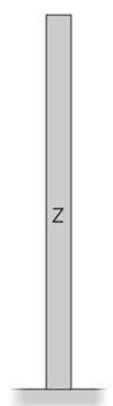

SIDE VIEW

X: horizontal. Y: vertical. Z: lateral = all must be true
 W = must be perfectly symmetrical/square

MINIMALIST WARDROBE

Door Specification

Max Door Weight: 50kg,

Door Thickness: 35mm - 40mm,

Max Door Height: 2700mm

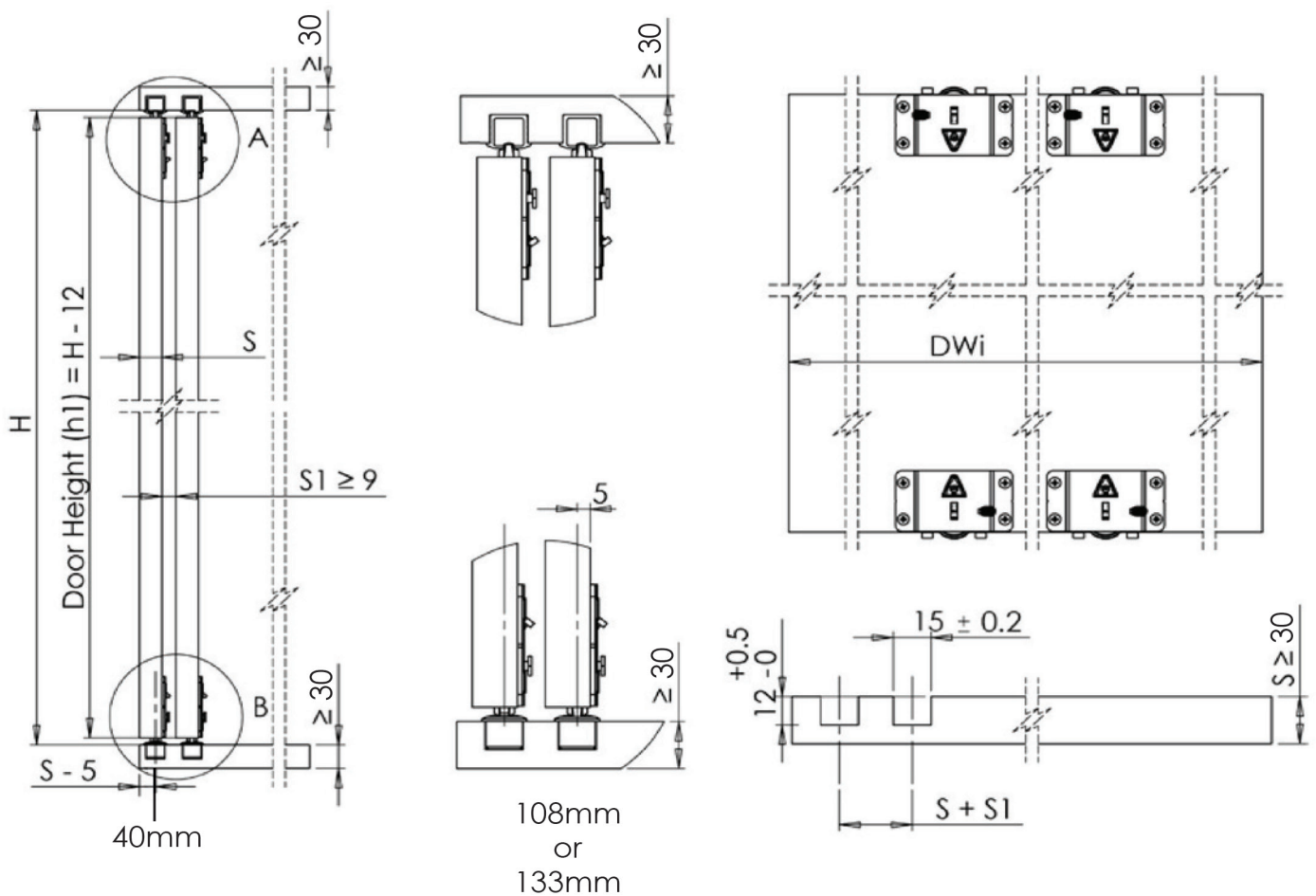

$$DWi - \text{Door Width (2 Door)} = \frac{OW - 2F}{2} + 10$$

$$DWi - \text{Door Width (3 Door)} = \frac{OW - 2F}{3} + 15$$

S = Door Thickness, between 35mm and 40mm

OW - Opening Width

H - Inside Height of Wardrobe

h1 = Door Height, h1 = H - 12

F - Thickness of Frame

S1 = Gap between the doors

2 DOOR

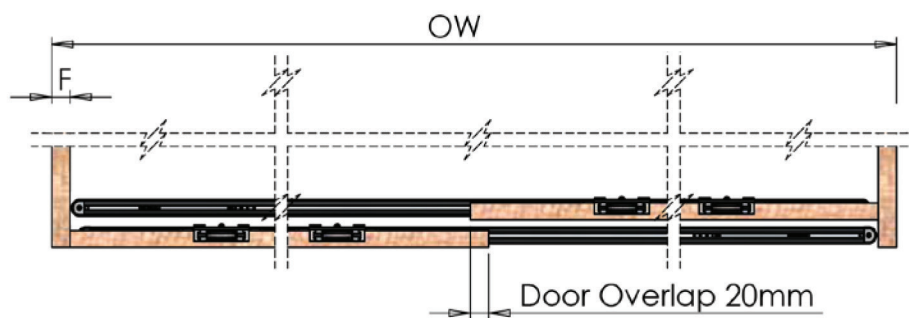

3 DOOR

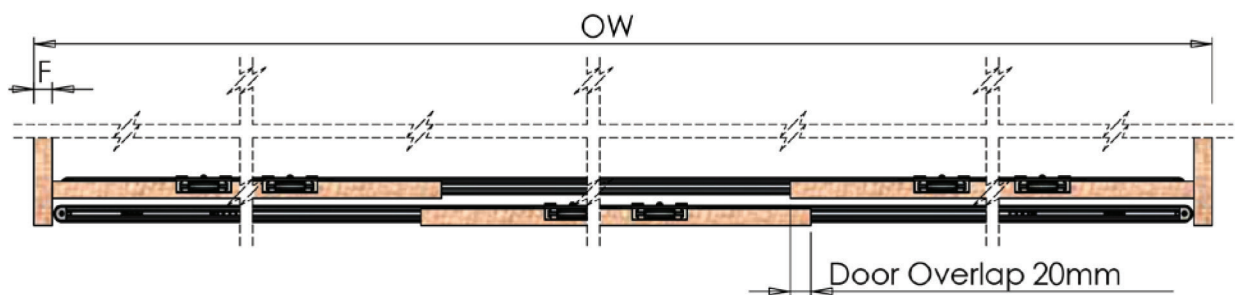

4 DOOR

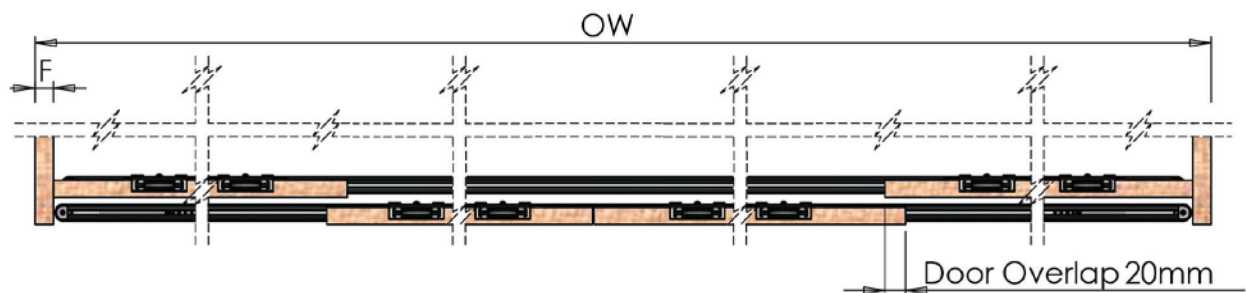

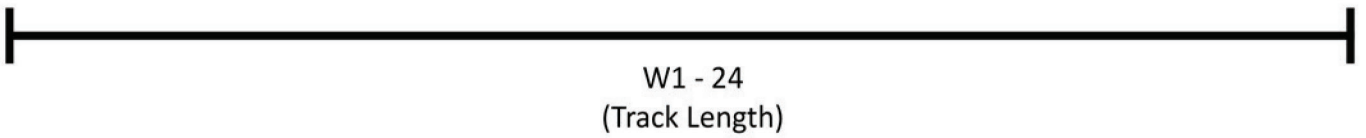
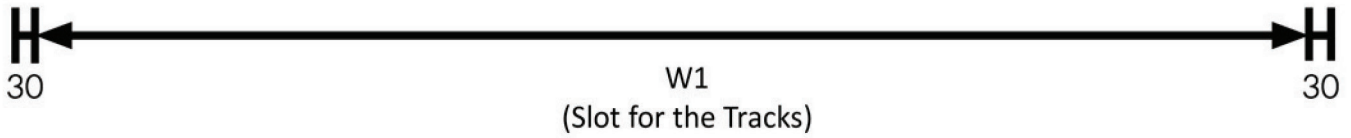

ASSEMBLE FRAME TO SIZE PRIOR TO FITTING GUIDE

Figure 1.

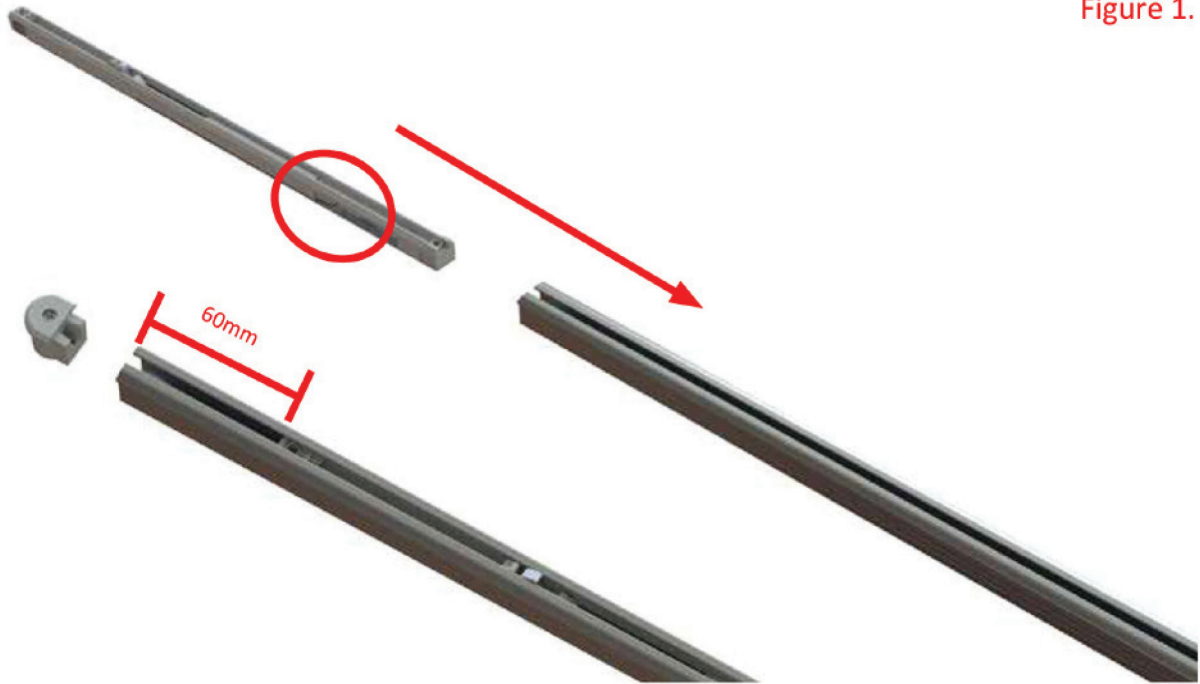

Figure 2.



1. Place the dampers 60mm into the top track*. Ensure the dampers are facing in the correct direction as guided in **Figure 1**.
2. Once the dampers have been placed. Place the track end Caps into the track, as guided in **Figure 2**.

NOTE:

*The bottom tracks do not require dampers

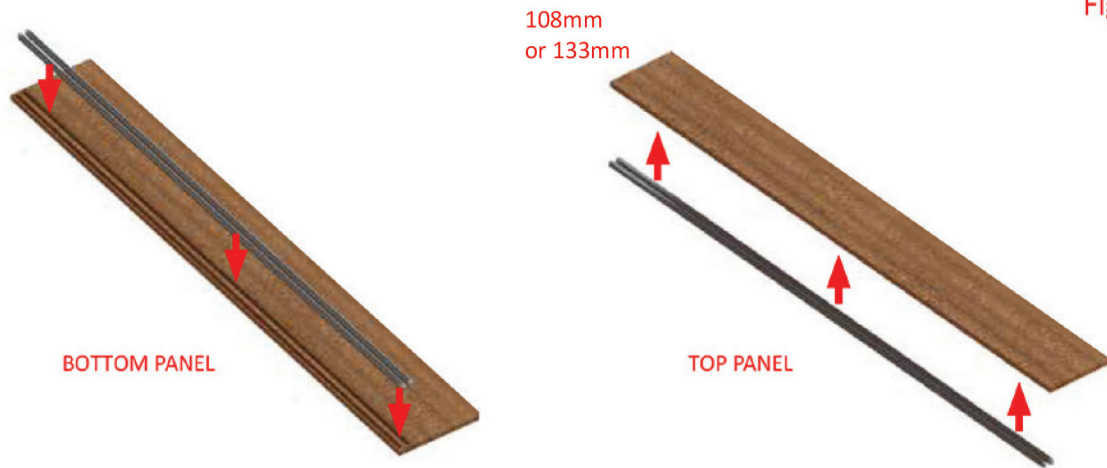

Figure 3.

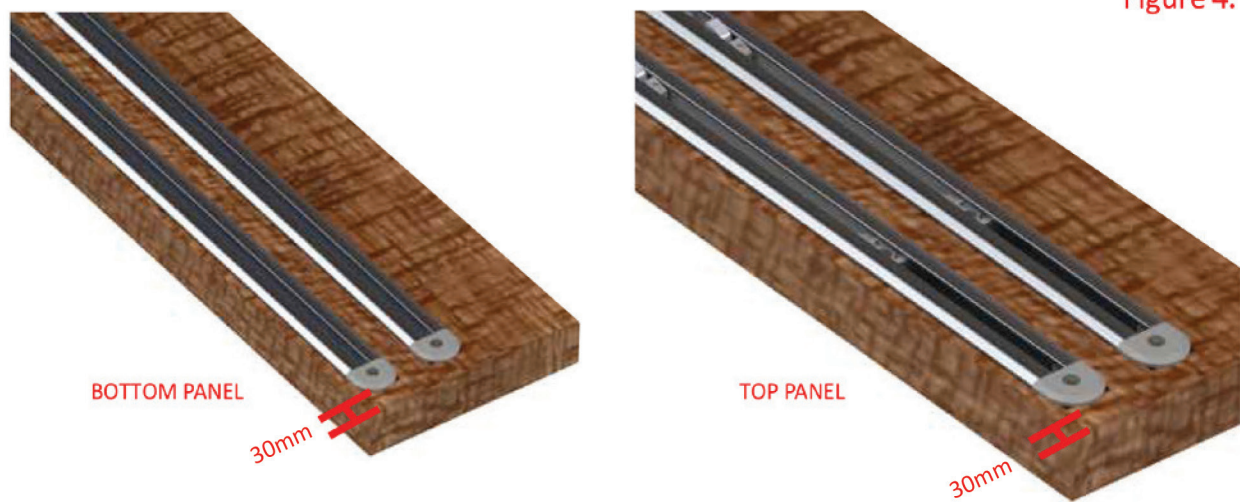

Figure 4.

1. Place the track assembly into the slots on the bottom panel. Repeat this step for the top panel, as guided in **Figure 3**.
2. Tighten the Track end stops to fix, as guided in **Figure 4**.



Figure 5.

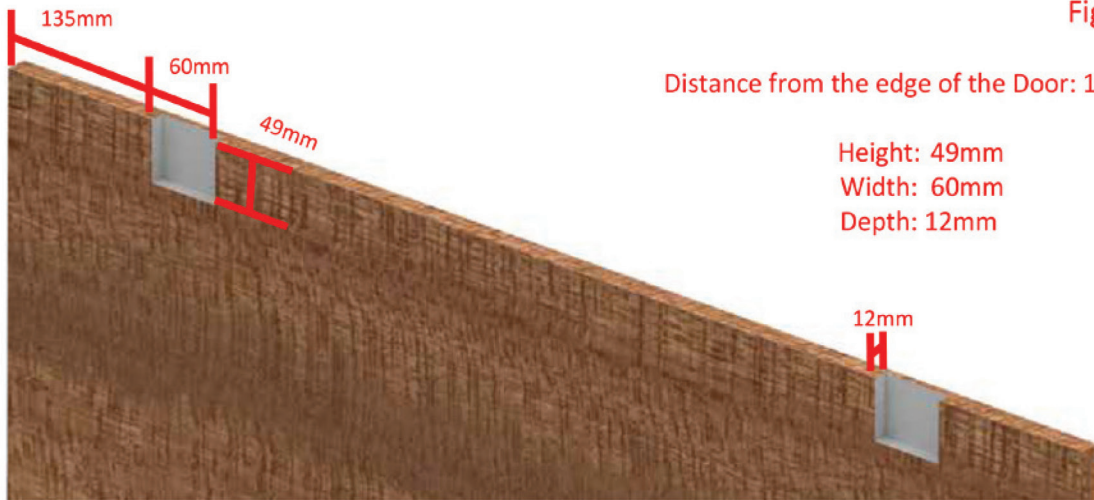

Figure 6.

Distance from the edge of the Door: 135mm

Height: 49mm
Width: 60mm
Depth: 12mm

1. Ensure the slots are symmetrical when cut.
2. Cut out the slots required using the dimensions guided in **Figure 6**.

Figure 7.

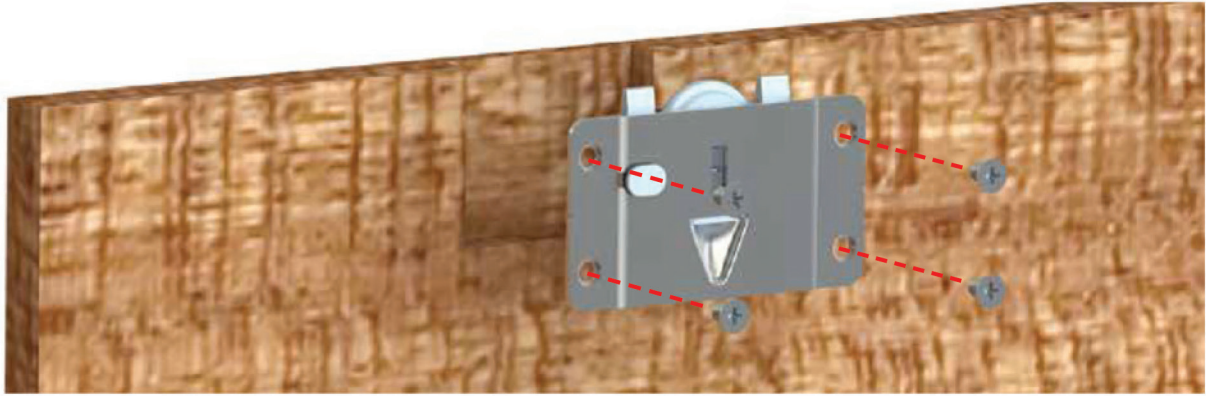

Figure 8.

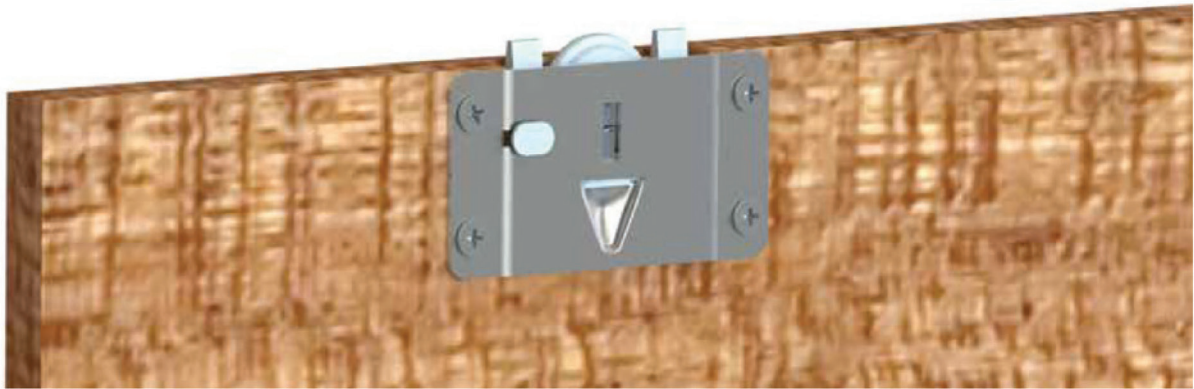
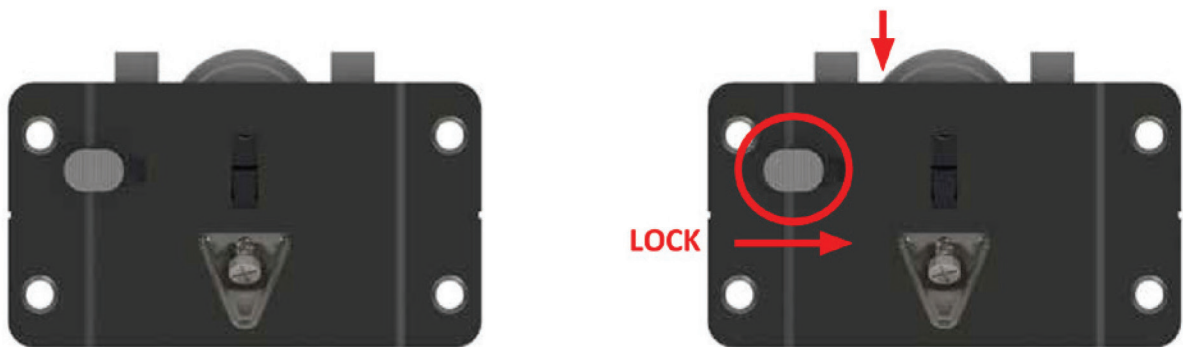

Figure 9.



1. Fix the rollers to the door using the screws supplied, as guided in **Figures 7 and 8**.
2. Ensure the rollers are horizontal during the installation process. Lock the rollers by pushing down the wheel and sliding the clip inwards, as guided in **Figure 9**.

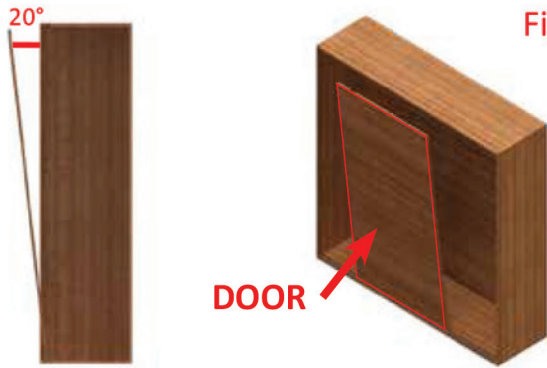

Figure 9.

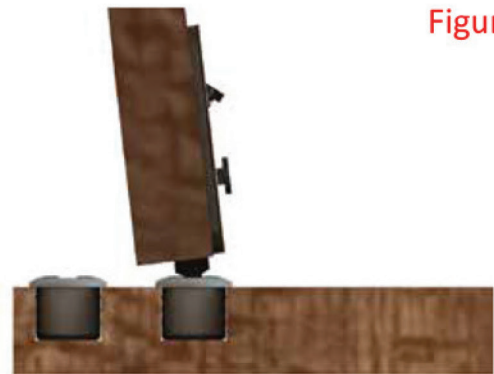

Figure 10.

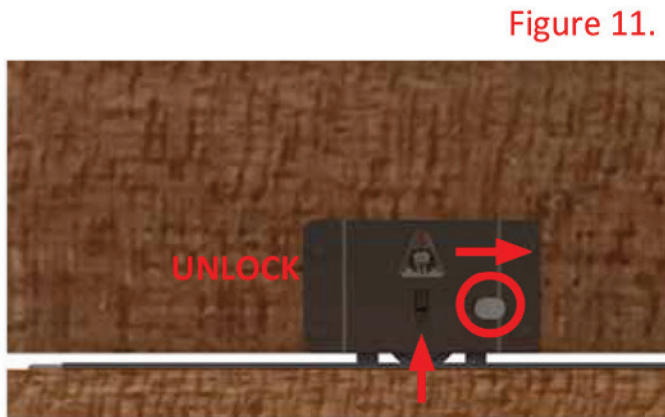

Figure 11.

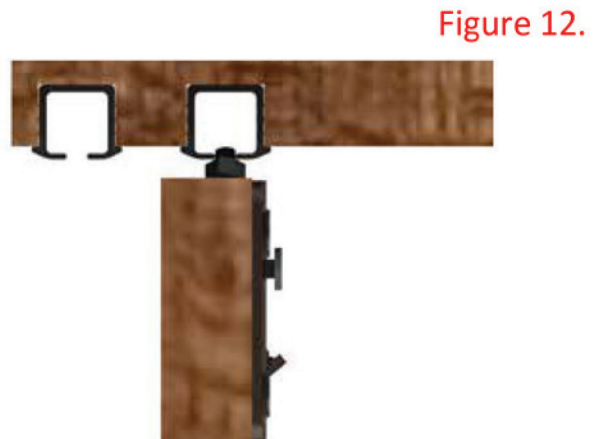

Figure 12.

1. Place the inner door/s on the centre of the bottom track. Ensure the door/s are not tilted more than 20° during installation, as guided in **Figure 9**.
2. Softly push the inner door/s onto the bottom track as guided in **Figure 10**.
3. Unlock the roller by pushing up the wheel and sliding the clip outwards, as guided in **Figure 11**.
4. Carefully direct the upper roller into position as guided in **Figure 12**, then unlock the roller.
5. Repeat the previous 4 steps for the outer door.



Figure 13.

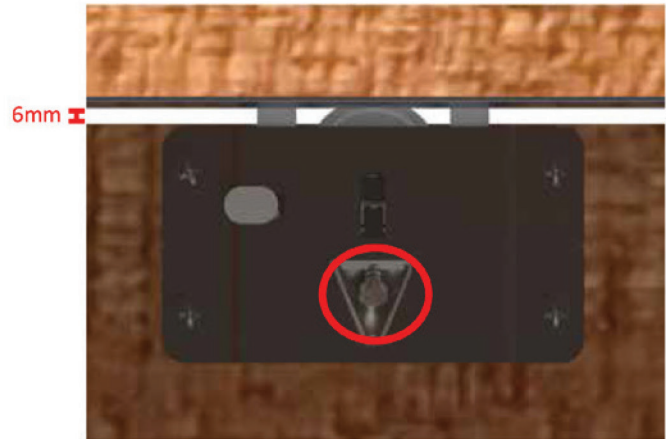

Figure 14.

Figure 15.



1. Push the door to the end of the track, as guided in **Figure 13**. This will position the damper.
2. Locate the screw on the face of the roller and screw to regulate the door gap. Repeat this step for all of the rollers, until the perfect gap has been achieved, as guided in **Figure 7**.
3. Using the Allen Key, fix the dampers, as guided in **Figure 7**. Ensure both ends and all dampers have been fixed.