



Trade, DIY, Bulk

Please be aware that we use narrower doors for this product whether panelled or glazed, they may have narrower panels or glass than the image shown, this is because the timber sections that make up the doors construction remain the same size across the full range of door sizes and the frame pack may be larger (wider) than noted on the site

XL JOINERY LTD

EASI-SLIDE ASSEMBLY INSTRUCTIONS

OAK & WHITE FRAMES

PLEASE READ AND UNDERSTAND THESE INSTRUCTIONS FULLY PRIOR TO STARTING INSTALLATION. IT IS STRONGLY RECOMMENDED THAT A COMPETENT TRADES PERSON INSTALLS THIS PRODUCT.

- 0 -



Trade, DIY, Bulk

INTRODUCTION

Multiple opening configurations are available for the Sliding Door Frame system based upon the layout of the doors and sidelights. Any door and sidelight can be used with maximum dimensions of 1981 x 838 x 35mm and a recommended maximum weight of 40kg each for the sliding doors. The maximum frame width is 3500mm allowing for a maximum combination of 4 x 838mm wide doors and sidelights in total. Any reference to “sidelights” refers to any 1981mm high product, e.g. a 1981 x 838 x 35mm “door” can be used as a “sidelight”. This product is only suitable for 35mm thick doors.

NOTE: Obscure, Patterned and Bevel Glazed doors MUST have the glass pattern detail facing the same way for all doors and sidelights.

FRAME CONFIGURATION EXAMPLE

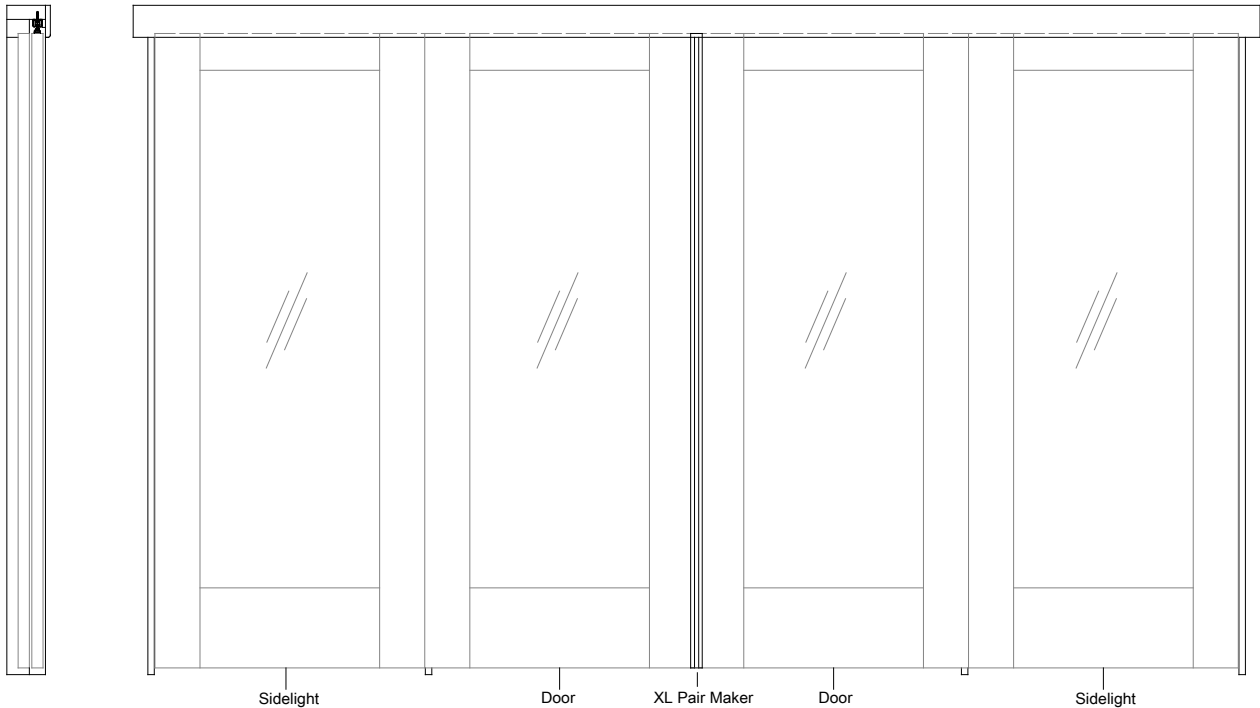
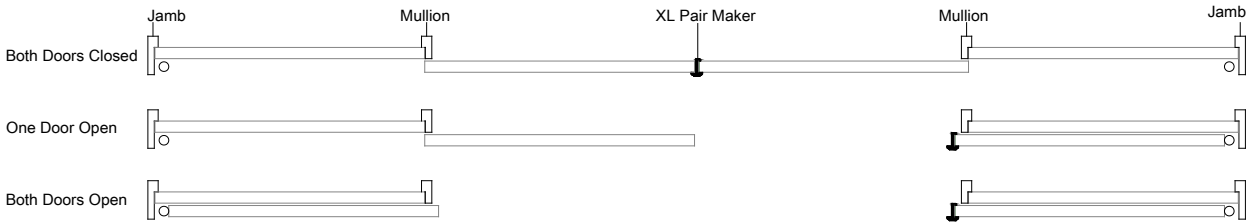

CONTENTS

Check that all the components listed below are present and in good condition prior to treating and assembling the product.

NOTE: Depending on the door configuration used, there may be some hardware components remaining after assembly. E.g. If only a single sliding door is used then there will be spare Plated 4 Wheel carriers and Track Stops left over.

FRAME PACK COMPONENTS (SUPPLIED)

- Jamb x 2 (Left and Right Hand)
- Mullions x 2 (Left and Right hand)
- Head x 1

ANCILLIARY FIXINGS (NOT SUPPLIED)

- Jamb Fixing Screws: 4 x 150mm/ 4 x 75mm
- Mullion Fixing Screws: 8 x 150mm
- 15mm Aluminium Surface Channel Screws x 10
- 35mm Round Head Top Track Fixing Screws x 10



Trade, DIY, Bulk

HARDWARE COMPONENTS (SUPPLIED)

Head Fix Aluminium Track x 1



Aluminium Surface Channel x 1



Plated 4 Wheel Carrier x 4



Spring Loaded Floor Guide x 4



Track Stop x 4

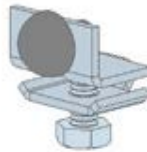

NOTE: Door Hardware, Handles and Frame to Wall Fixings are not supplied. (See last page)

STAINING/ PAINTING OF TIMBER COMPONENTS

Bare timber doors and frame products will require a light sanding prior to finishing. Take care when finishing glazed doors to ensure that the finish does not go on the glass. Secondary protection such as masking tape may be necessary, including on Paint and Peel protected doors.

All timber surfaces should be fully finished. When applying the finish pay particular attention to sealing the timber end grain on the tops and bottoms of the doors: Ensure that all hardware cut-outs are also fully treated.

PRE-FINISHING SUMMARY

DO

- Use a good quality paint, stain or varnish.
- Apply to all faces and edges.
- Apply the same number of coats equally to the face, edges, lock, latch and hinge cut-outs.
- Apply at least 1 coat of finish as soon as possible after unpacking the door
- Check that the finish manufacturers' product is suitable for veneered/ engineered doors

DO NOT

- Use thin penetrating seals, oils, wax, dyes or hard, brittle finishes.
- Use thinned/ mixed paints or stains.
- Mix incompatible products, e.g. paint on one door face and stain on the opposite face.

MAINTENANCE

Regular maintenance of the finish must be carried out to ensure the long term protection of the doors.

Note: Storing, installing or finishing the product in a manner not detailed in these instructions may invalidate the warranty.



PREPARING THE OPENING

The opening should be approximately 10mm wider than the assembled frame dimensions to facilitate fitting and squaring of the frame. The opening should be level and square prior to installing the frame. Failure to ensure this may impede the proper functioning of the doors. Please refer to the example below for fitting.

BRICKWORK OPENING EXAMPLE

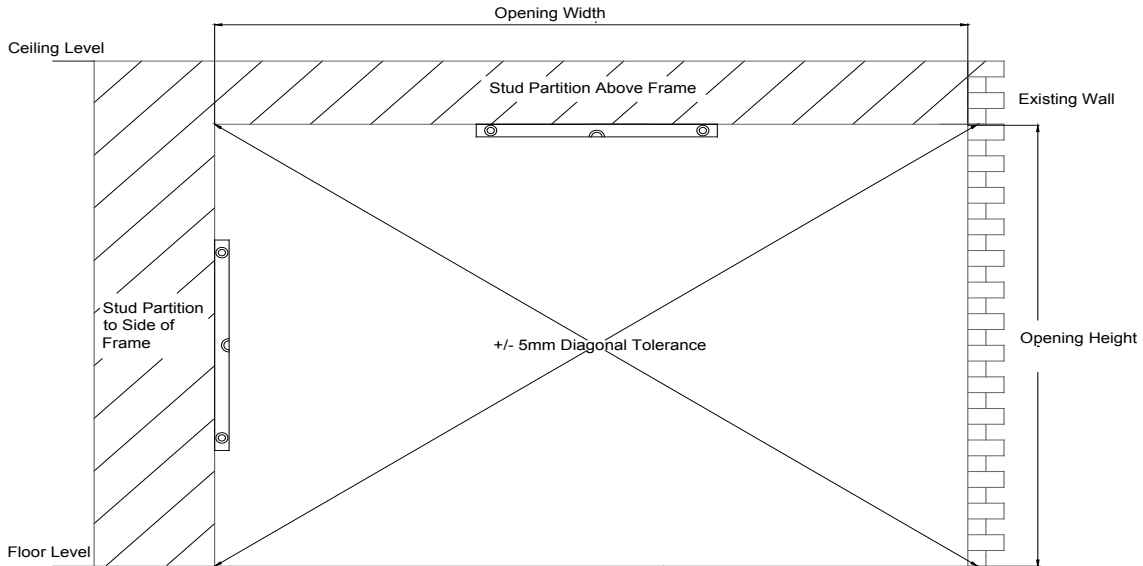

ASSEMBLING THE FRAME

The Jamb and Mullions are over-sized in length to allow for a 21mm maximum thickness floor covering to be fitted **after** frame installation. If the frame is fitted on top of the floor covering then the Jamb and Mullion height will need reducing from the bottom edges. The distance between the bottom edge of the Sliding Doors and the upper floor surface, (not the Aluminium Surface Channel), should be 16mm minimum.

It is important that the floor is level and even: If the Aluminium Surface Channel is fitted to a sloped or uneven floor, the Spring Loaded Floor Guides may disengage during operation.

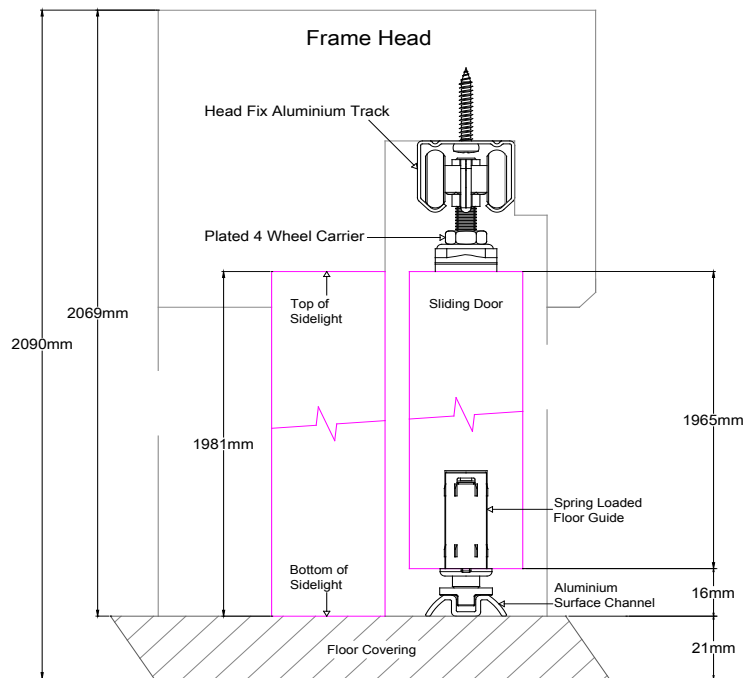
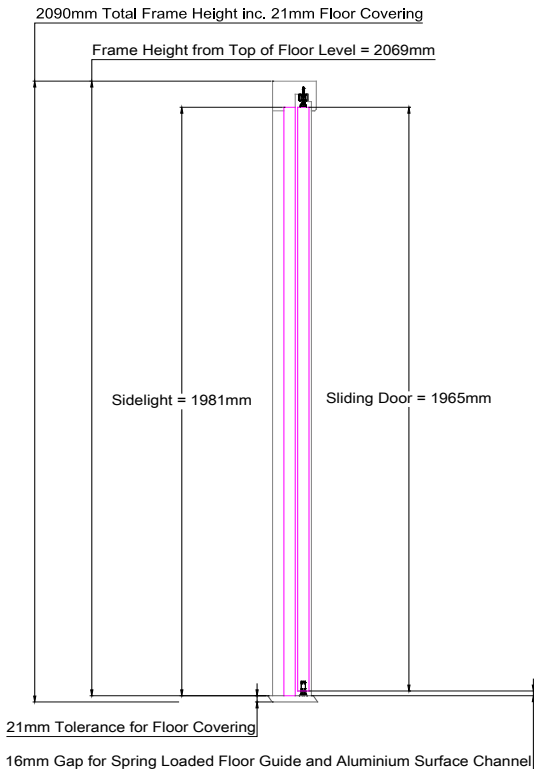



Trade, DIY, Bulk

1. Measure the brickwork/ partition opening and decide upon a suitable opening configuration: The diagram on Page 1 gives a common example although there are many other potential configurations, e.g. single Sliding Door and a single Sidelight.
2. Doors and Sidelights can be trimmed in the width to allow some adjustment to the required opening width: Maximum trimming information is included with the relevant product.
3. Unpack and loosely assemble the Jambs, Mullions and Frame Head on a clean flat surface: The vertical frame components are pre-cut at the top to sit in the Frame Head rebate.
4. Use the Sliding Doors and Sidelights to determine distances between the vertical frame components: Allow sufficient clearance between the Mullions for a Pair Maker (if required). The Sliding Doors must sit in front of the face of the Mullions when in the open and closed position, (See diagram below)

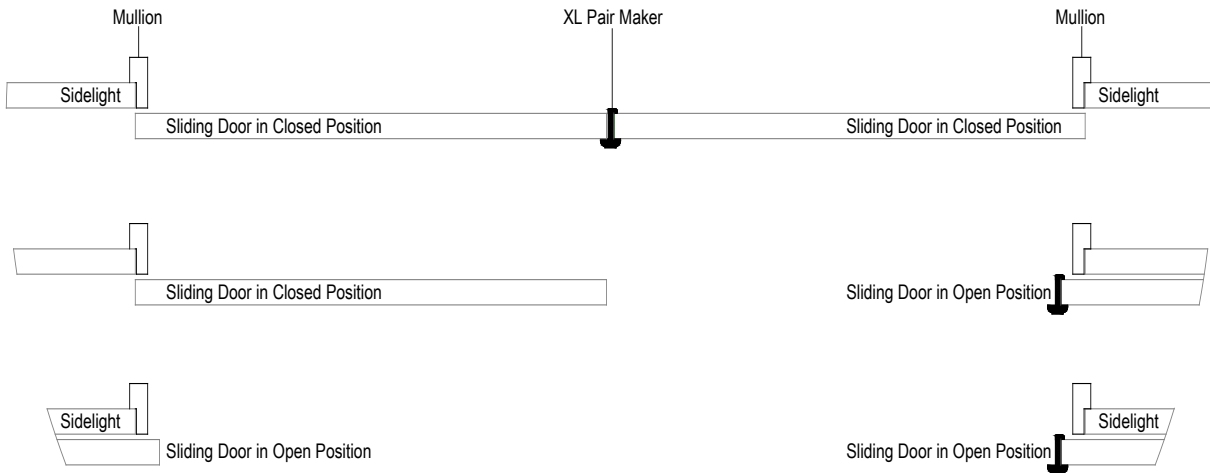

5. Double check that the finalised external frame dimensions suits the opening.
6. Ensure the loosely assembled frame is square. Mark the screw positions on the Frame Head as per the diagram below and pre-drill through the head and into the centre thickness of the vertical members.
7. Apply wood adhesive to the adjoining surfaces between the vertical frame components and the Frame Head, prior to screwing the jointed components together. Wipe off any excess wood adhesive with a clean cloth.
8. Ensure the frame joints are tight and that the frame is kept square prior to installation.

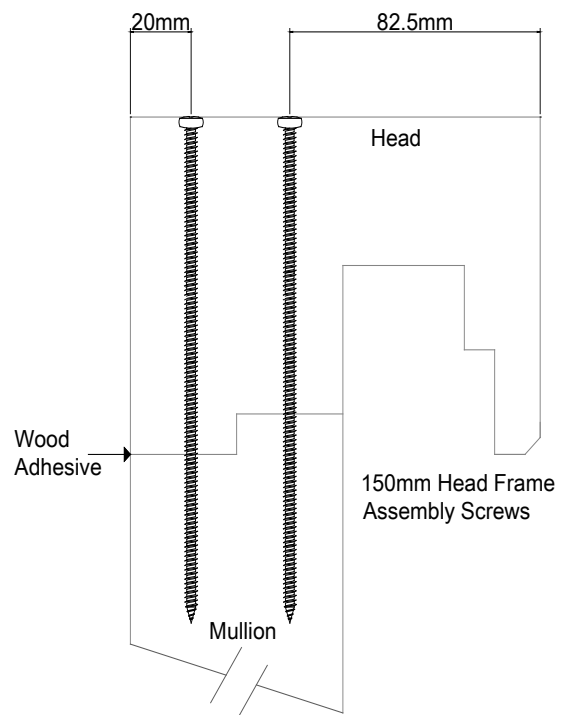
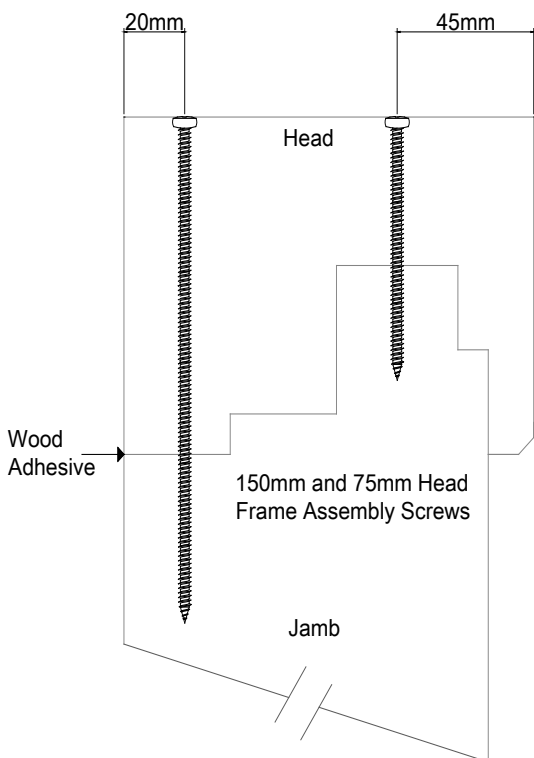



Trade, DIY, Bulk

INSTALL THE ASSEMBLED FRAME

1. Depending on the opening configuration, the installer may permanently fix the sidelights into the vertical frame components prior to locating the frame in the opening.
2. Fit the frame into the opening, ensuring it is fitted square and level in both the horizontal and vertical plane. If necessary, use packers between the frame and opening: Check that the frame diagonal tolerance is 2mm or less.
3. Fit the frame through the Jambs and into the adjacent walls and countersink the screws so that they are below the surface of the frame, (75mm screws recommended, not supplied).
4. Fit the frame through the Frame Head and into stud partition/ ceiling above at approximately 450mm centres and 100mm from each Jamb, (100mm screws recommended, not supplied). Ensure that there are no service pipes or wires near to the screws.
5. Countersink the screws so that they are below the surface of the Frame Head: Failure to do so will prevent proper fitting of the Head Fix Aluminium Track.
6. If fitting into the ceiling, try to screw into the ceiling joists for a secure fitting, (otherwise use heavy duty expansion bolts or similar, not supplied).

INSTALL THE ASSEMBLED FRAME

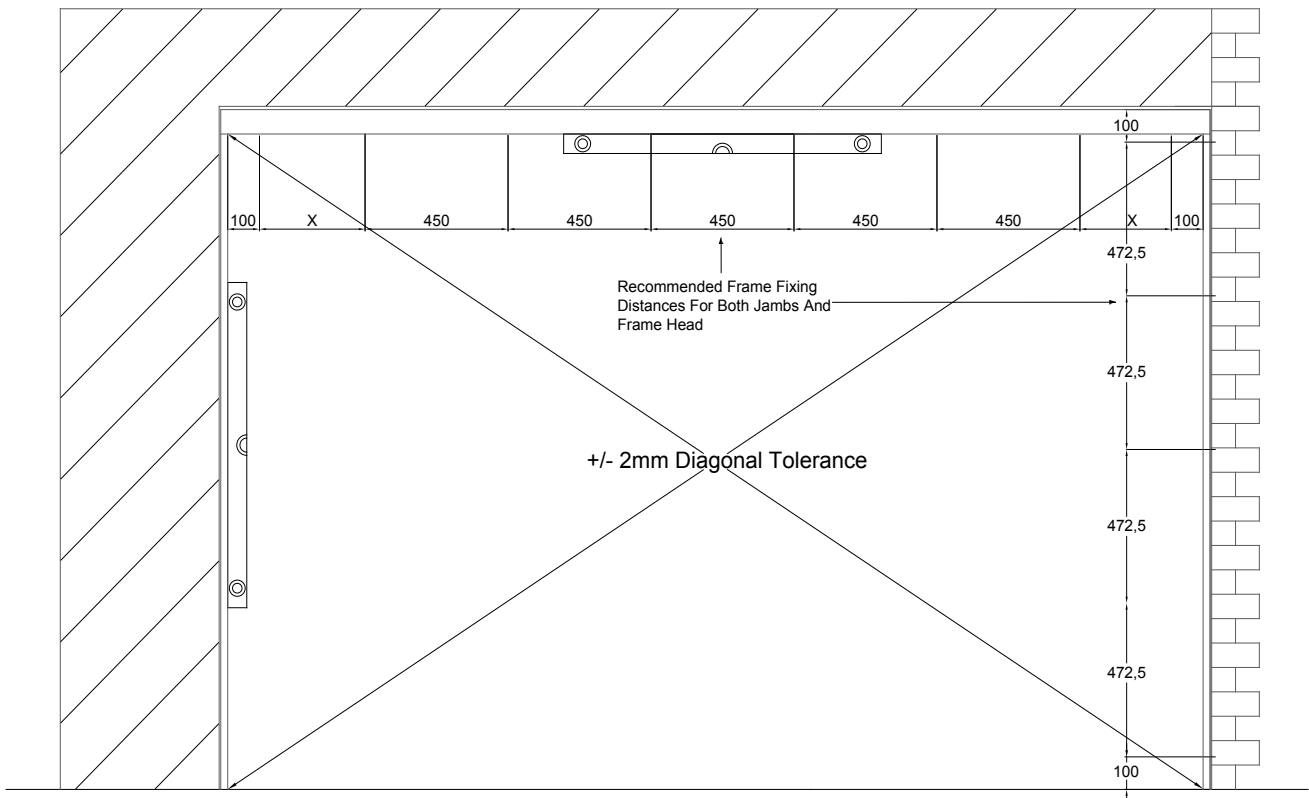

NOTE: This hardware system is designed to be “Top Hung”: Therefore the weight of the doors will be carried by the Head Fix Aluminium Track. As such it is necessary to ensure that there are secure fixings through the Frame Head into the partition/ ceiling above. Failure to do so may result in the Frame Head bowing which will adversely affect the functioning of the hardware system.



FIT THE SLIDING DOOR HARDWARE

The bottom rails of the Sliding Door(s) will need trimming in height by 16mm to accommodate the Spring Loaded Floor Guides and Aluminium Surface Channel: This does not invalidate the door warranty if the sliding door is fitted as part of an XL Joinery Sliding Door Frame Set and the bottom of the door is treated correctly.

1. Sidelights should be fitted between the Jambs and Mullions and the bottom rail should be flush with the floor covering: Sidelights can be screw fixed into their stile edges through the Jamb and Mullion prior to fixing the frame in the opening.
2. Reduce the height of the bottom rails of the Sliding Door(s) by 16mm to accommodate the hardware: The top rail of the Sliding Door(s) should **NOT** be reduced as this may result in the Sidelight and Sliding Door rails and profiles not aligning horizontally.
3. Detach the carrier from the Bracket of the Plated 4 Wheel Carriers and fit the Brackets at either end of the top edge of the Sliding Door(s). The Brackets should be located 50mm from the edge of the stiles to the centre of the Bracket. Pre-drill the screw holes prior to fixing.
4. Drill the Spring Loaded Floor Guide holes to the bottom rails of the Sliding Door(s) using a 12.7mm (1/2") wood bit. Ensure that the holes are drilled straight at 90 degrees to door edge. The holes should be located at the bottom edge of the Sliding Door(s) 50mm from the edge of the stiles to the centre of the Guide.
5. Fit the Spring Loaded Floor Guides into the holes and secure using the 4x12mm screws provided. Pre-drill the screw holes prior to fixing.

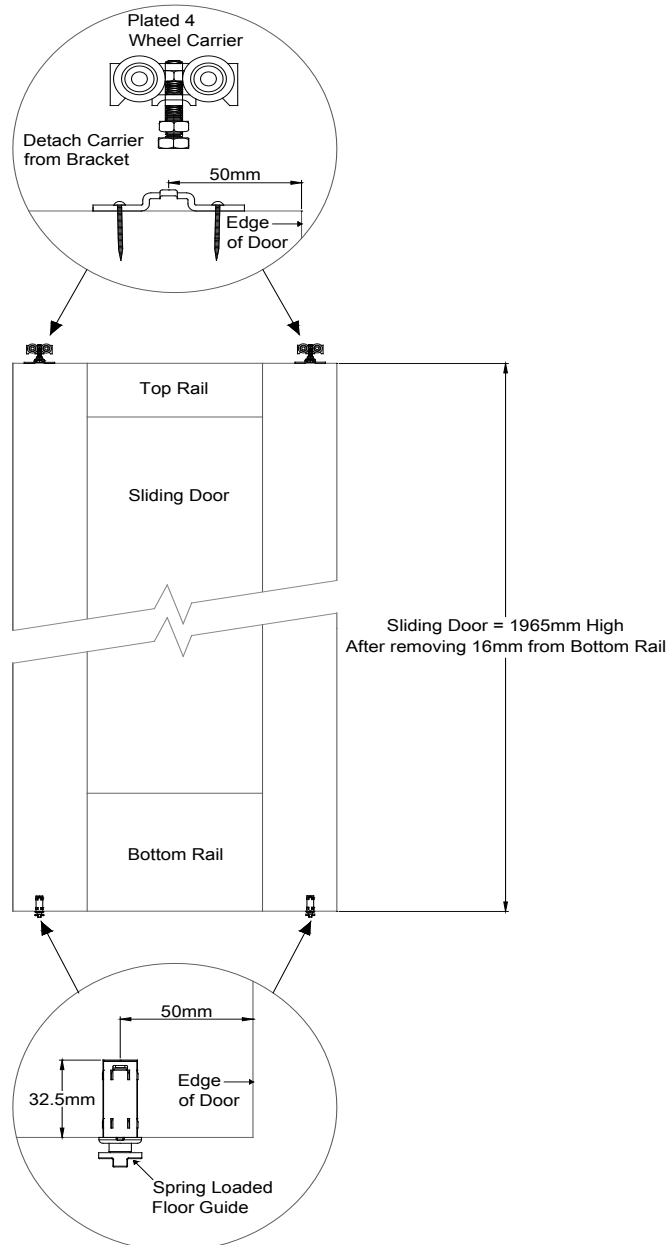



FIT THE HEAD FIX ALUMINIUM TRACK

The Head Fix Aluminium Track and Aluminium Surface Channel will require reducing in length depending on the final frame width.

1. Insert the Plated 4 Wheel Carriers and Track Stops into the Head Fix Aluminium Track prior to fitting the track to the frame Head. **Note:** Ensure that the correct numbers of components are inserted into the track in the correct order.
2. Screw the Head Fix Aluminium Track into the Frame Head through the pre-drilled holes utilizing the 6 x 35mm screws provided. Ensure that the track is fitted to the front of the Frame Head groove towards the pelmet. Please refer to diagram. **Note:** The Frame Head groove is wider than the track to allow for adjustment of the hardware.

FIT THE ALUMINIUM SURFACE CHANNEL

1. Ensure that the Aluminium Surface Channel is straight and in line with the Head Fix Aluminium Track.
2. Pre-drill the Aluminium Surface Channel and countersink the 4 x 15mm screw fixings. The distances can be adjusted to suit your floor covering, e.g. if fitted to floor tiles, the screws can be fixed through the grout lines. (If necessary, longer screws and/ or plugs can be used to suit the floor covering).

Typical Hardware Orientation of Plated 4 Wheel Carriers and Track Stops for 2 Sliding Doors

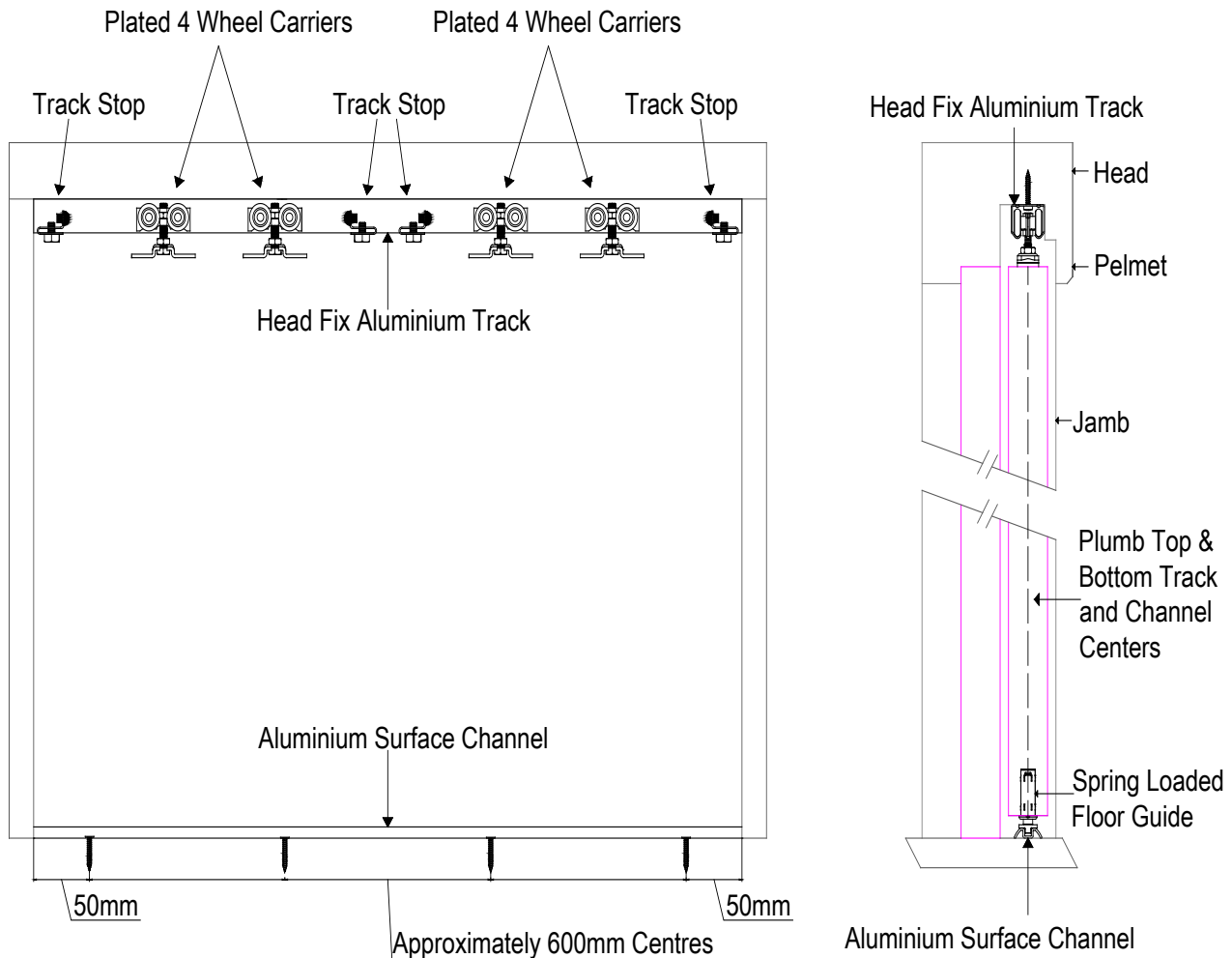



HANG THE SLIDING DOORS

1. Insert the Spring Loaded Floor Guides fitted to the Sliding Door(s) into the Aluminium Surface Channel and hook the Plated 4 Wheel Carrier Brackets onto the Carriers. Tighten the nut on the Carriers to secure the Bracket.
2. Adjust the Plated 4 Wheel Carrier Bolts to raise or lower the Sliding Door(s) until it is level with the Sidelight (if fitted)
3. Ensure the weight of the Sliding Door(s) rests on the Plated 4 Wheel Carriers and NOT on the Spring Loaded Floor Guides.
4. If there are 2 Sliding Doors, adjust the Plated 4 Wheel Carrier Bolts until the doors close evenly along their adjacent stiles.
5. If using a Pair Maker, it will require notching out at the top edge so that it fits underneath the Frame Head pelmet. **Note:** A Pair Maker will not open past the Mullion.
6. Adjust Track Stops so that Sliding Door(s) close together in the correct location and when opened, the Sliding Doors stop in the correct location.

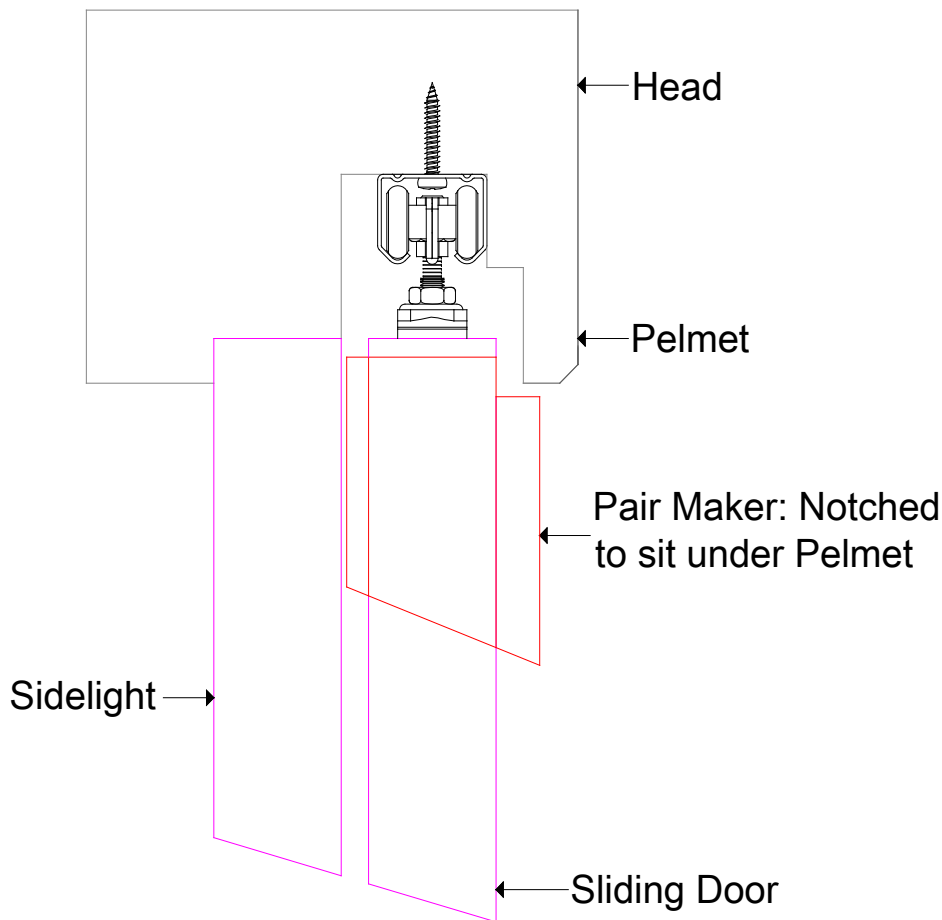

NOTES

Latches and Locks

In the event that the doors require a locking or latching mechanism, then suitable hardware can be purchased from most door hardware suppliers.

Handles

Flush mounted or recessed door handles are recommended to allow the doors to slide back fully: Protruding door handles/ knobs will prevent the doors from opening fully if they are located on both sides of the door. If locking or latching hardware is fitted, ensure that a compatible handle mechanism is used that does not restrict the doors from fully opening.