

MasterTrack FT60

Instruction Manual

Please take 3 minutes to watch the [installation video](#).

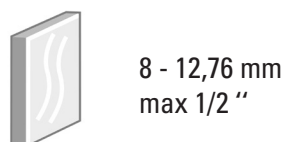

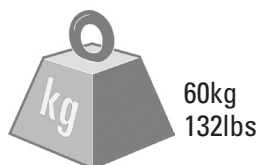
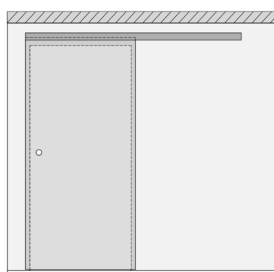
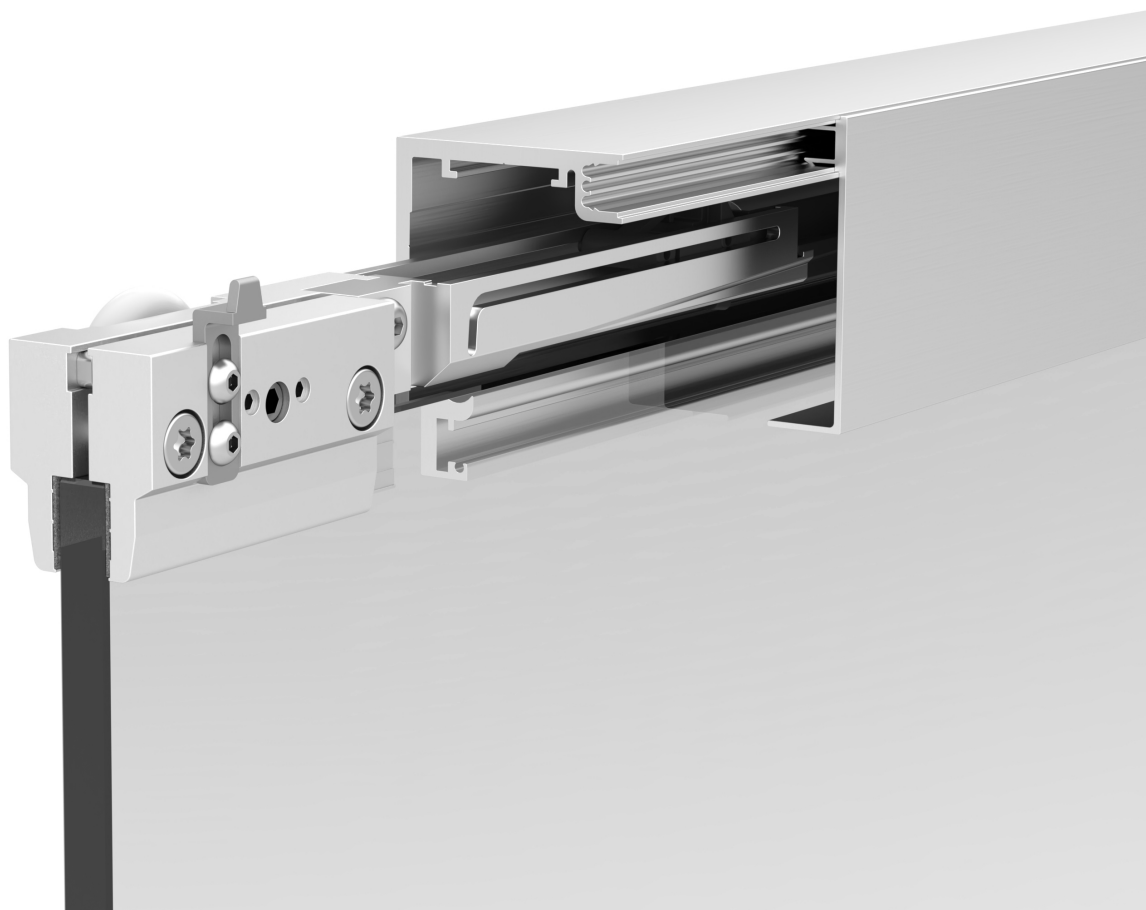
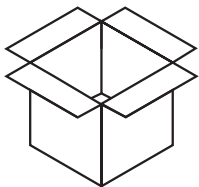

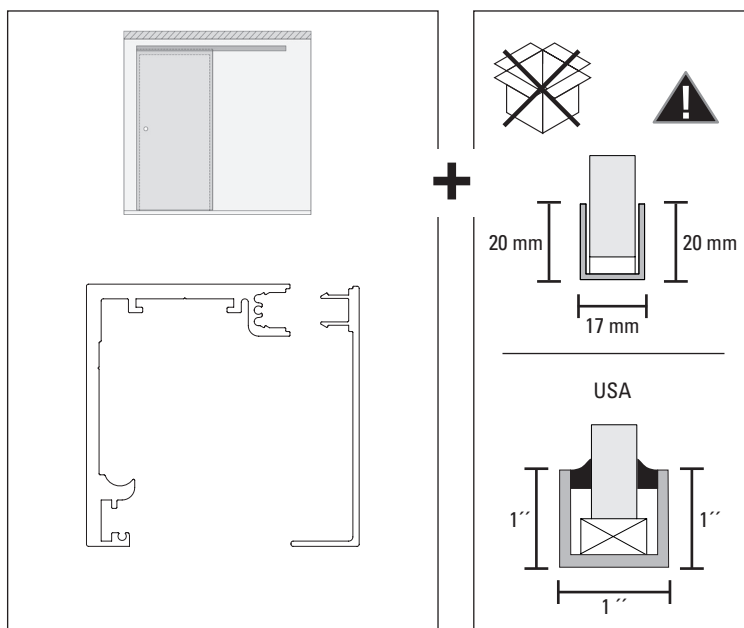
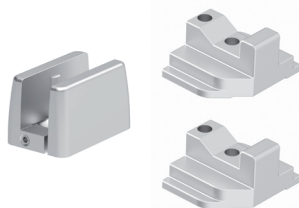
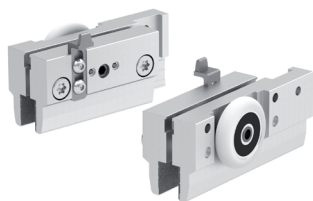

MasterTrack FT

60 kg (132 lbs)

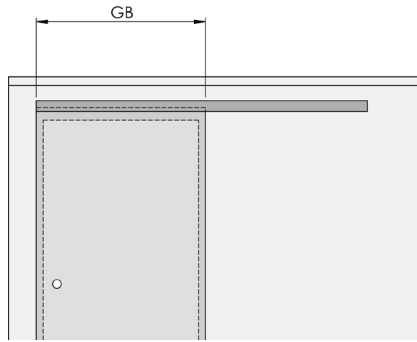



| | |
|---|-----------------|
|  | 60 kg (132 lbs) |
| GB (mm) | min 600 |
| USA (inch) | min 23 5/8 |

$$GH = H + X + 11,5 (7/16)$$

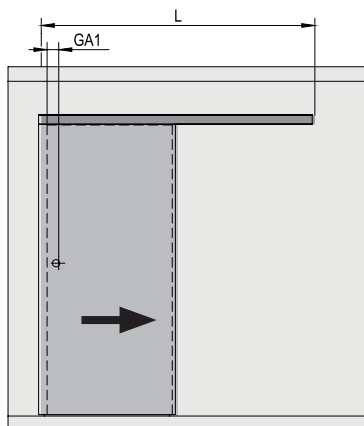
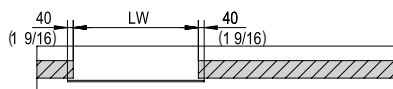
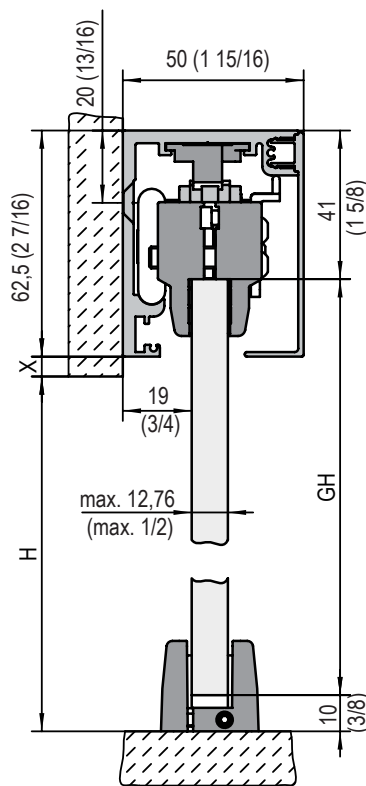



4

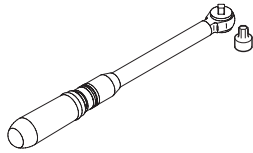

Torque wrench not included

2

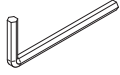

2,5

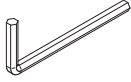

3

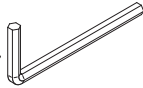

4

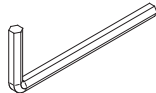

Mounting Kit



Mounting Kit not included, available for an extra cost for regular trade users, please contact info@directdoors.com for more information.

Glass Cleaner



05



Glass cleaner not included

01

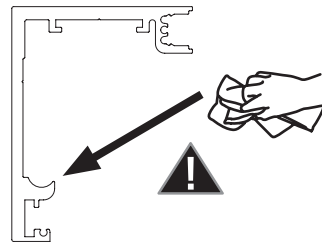
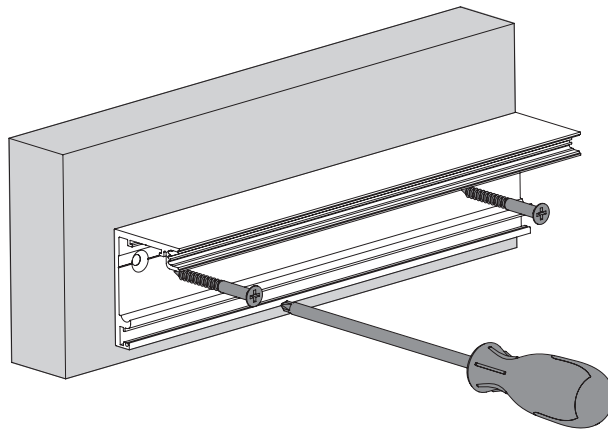

02

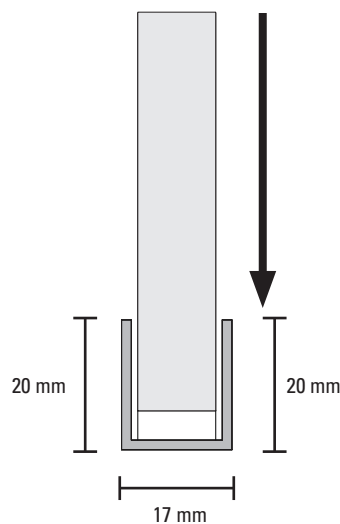

03

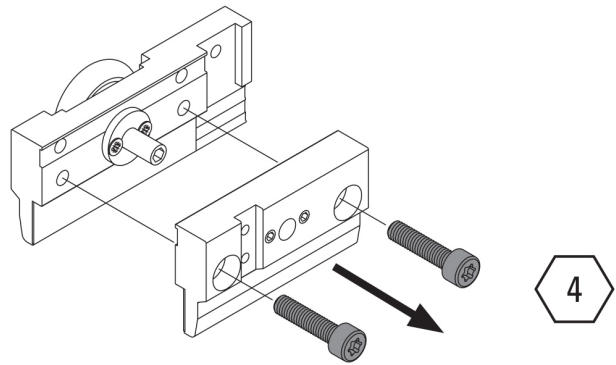
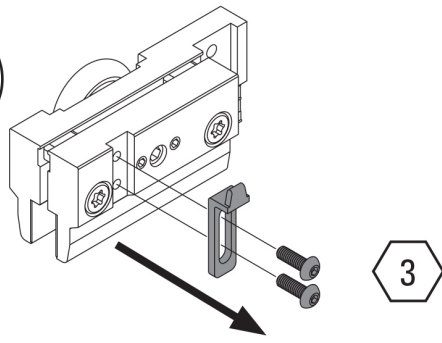

04

60 kg (132 lbs)



8 mm
(5/16 ")



10 mm
(3/8 ")



12 mm
(1/2 ")

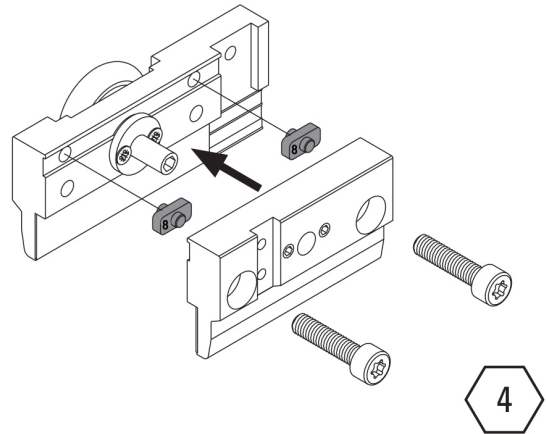

05

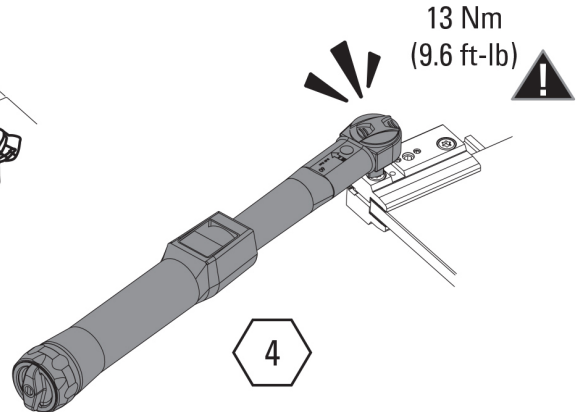
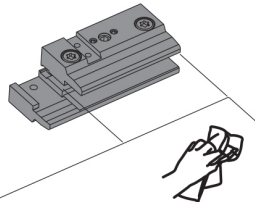

13 Nm
(9.6 ft-lb)

06

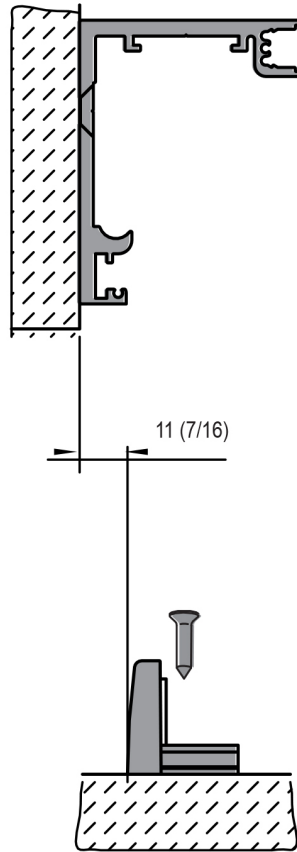
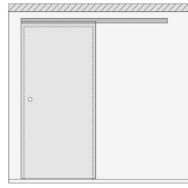

07

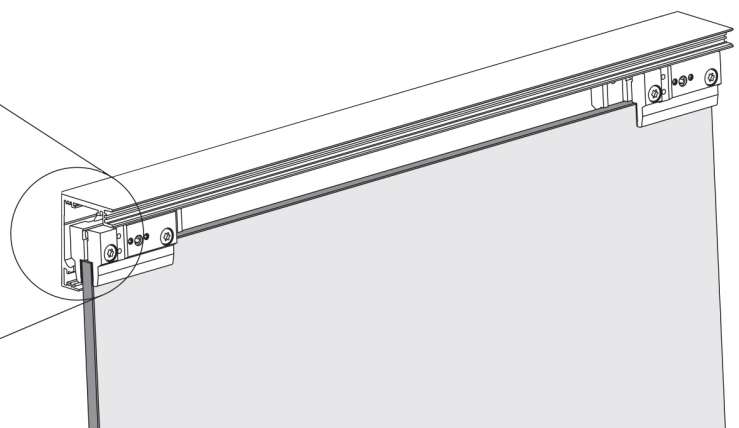
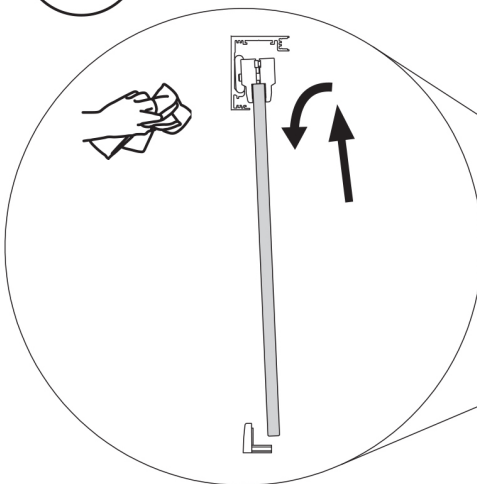

08

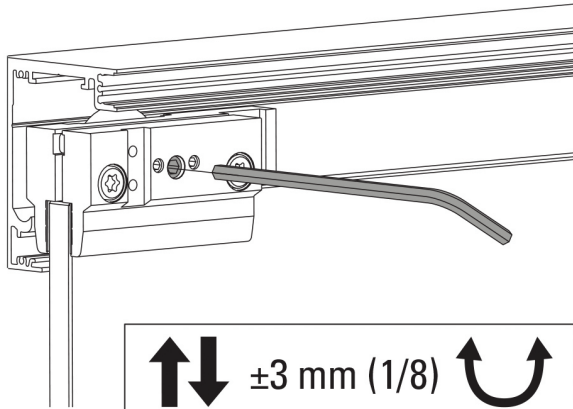

±3 mm (1/8)

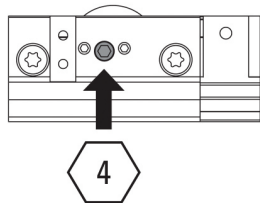

4

09

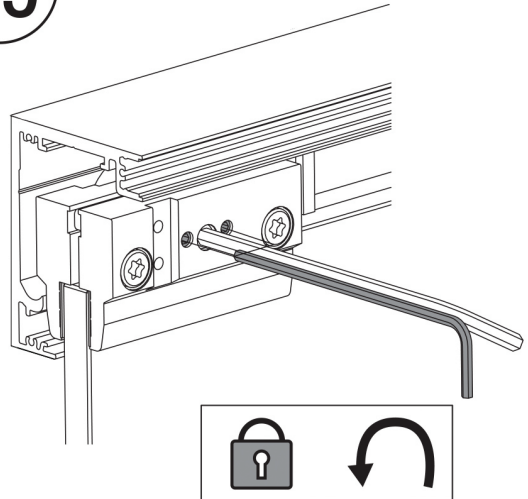

2,5

10

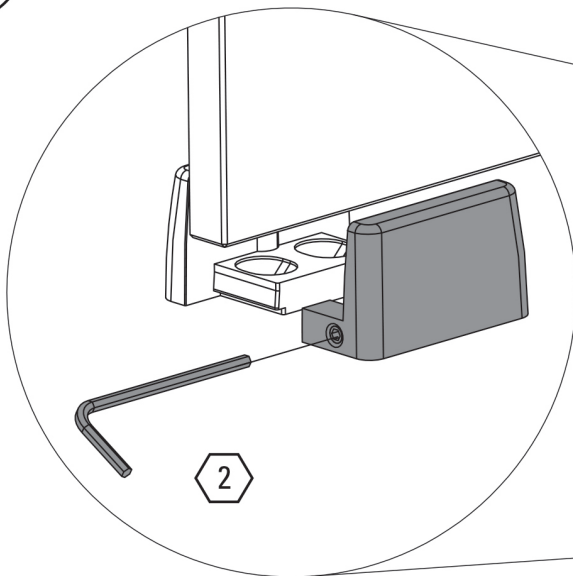

2

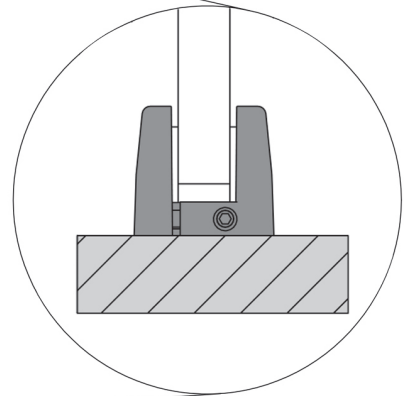

11

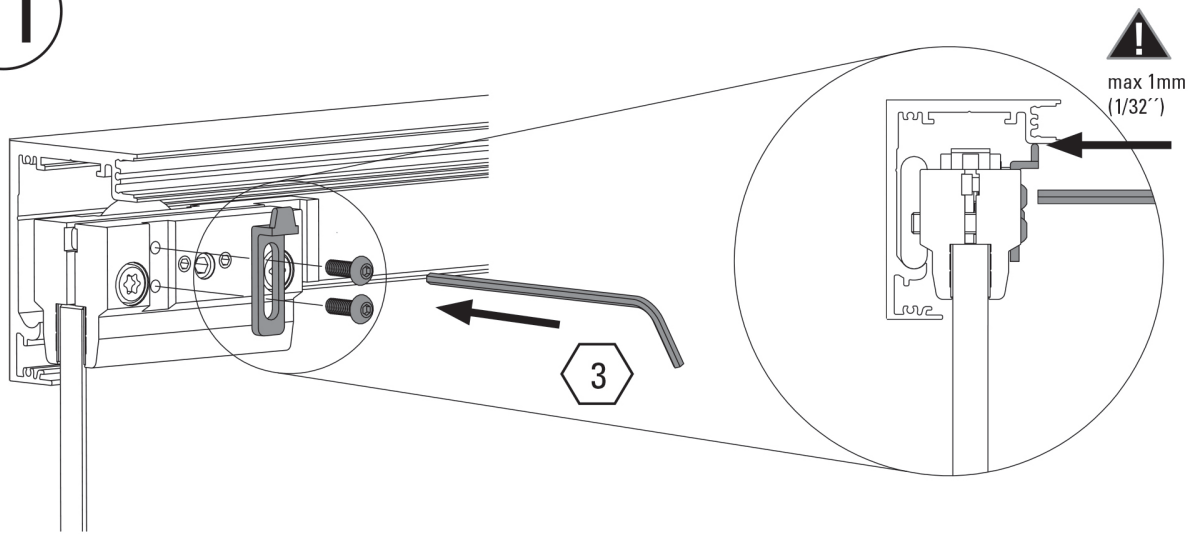

12

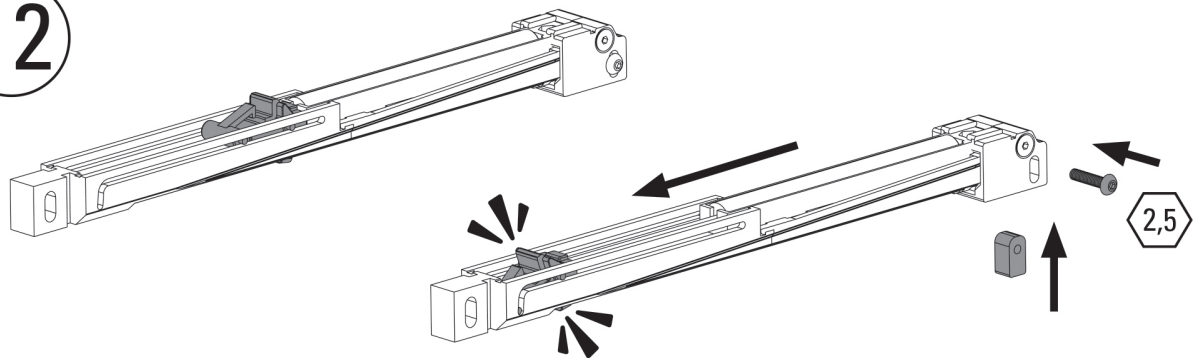

13

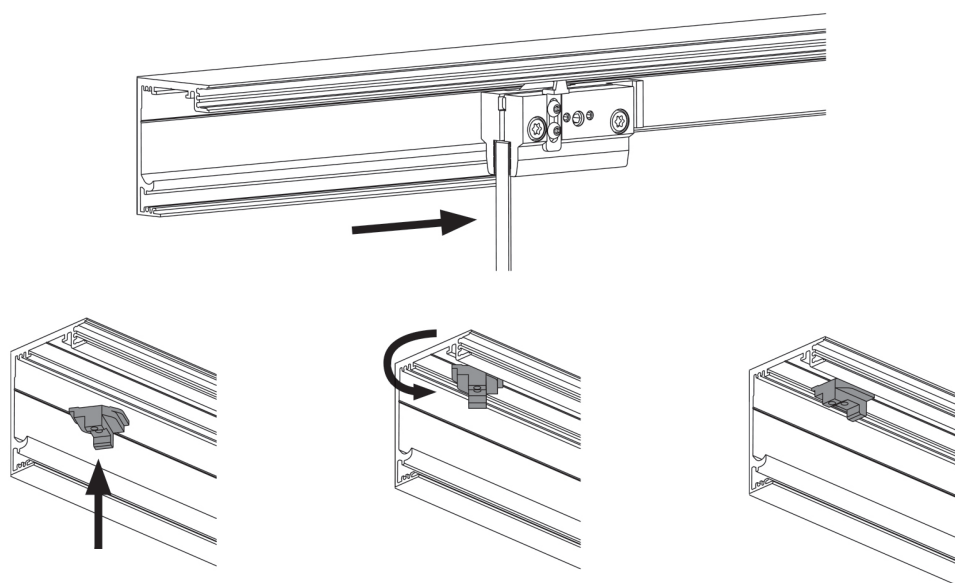

14

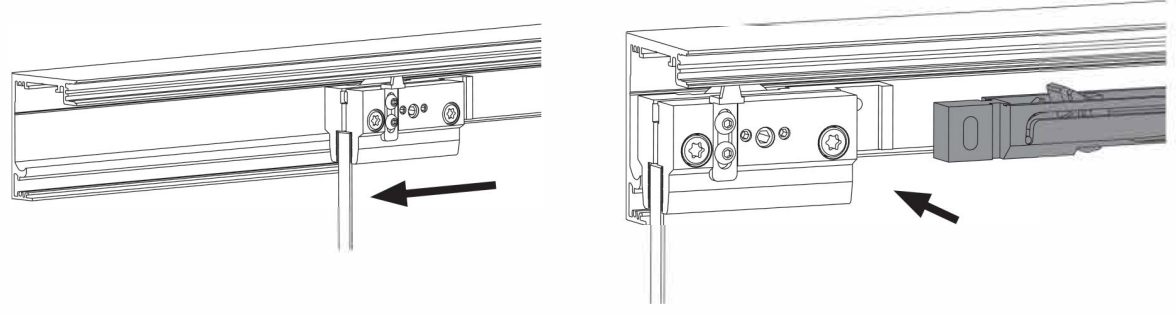

15

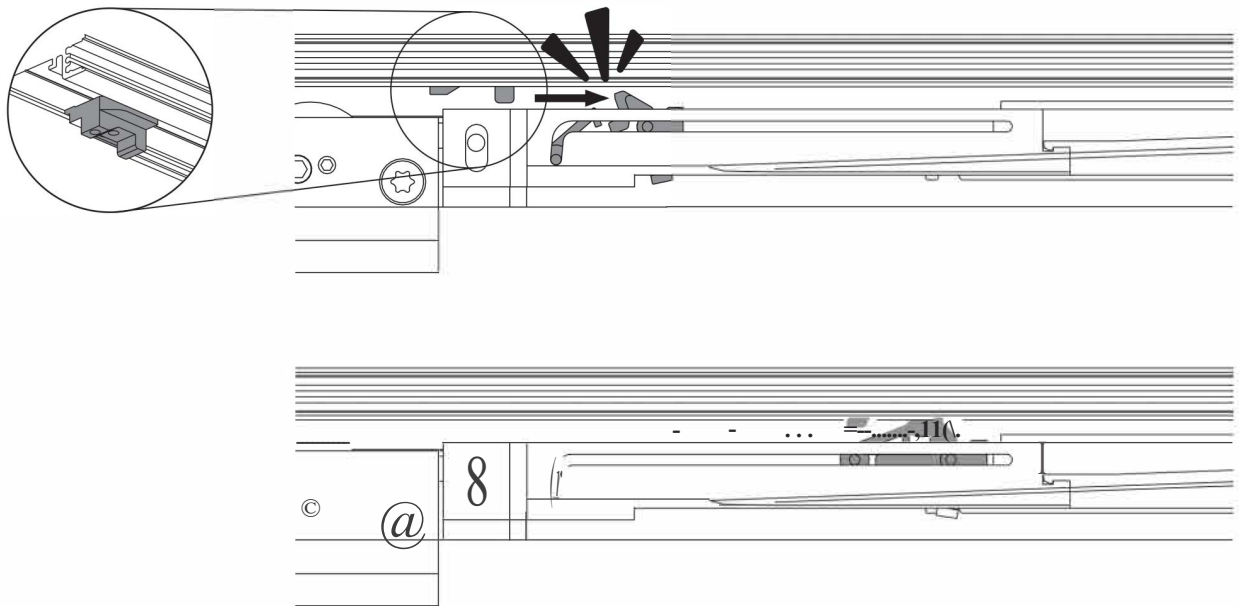

16

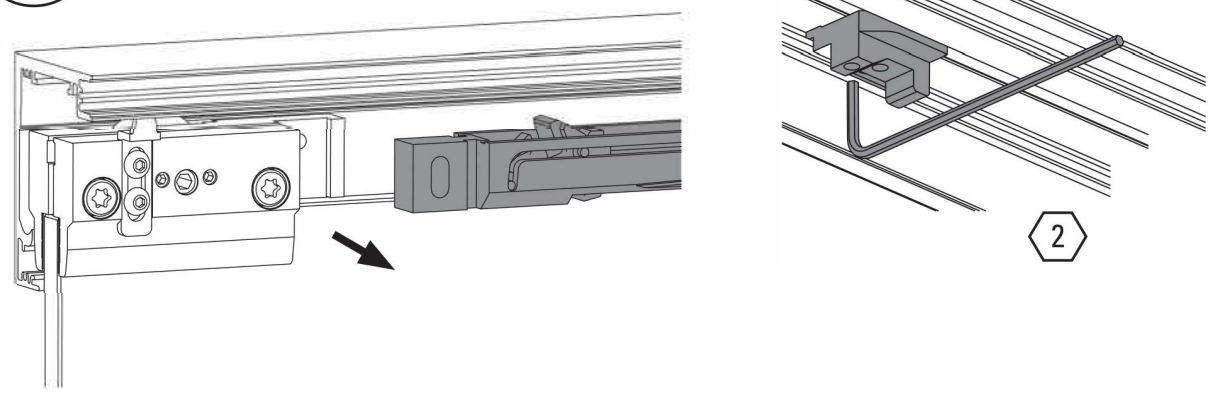

17

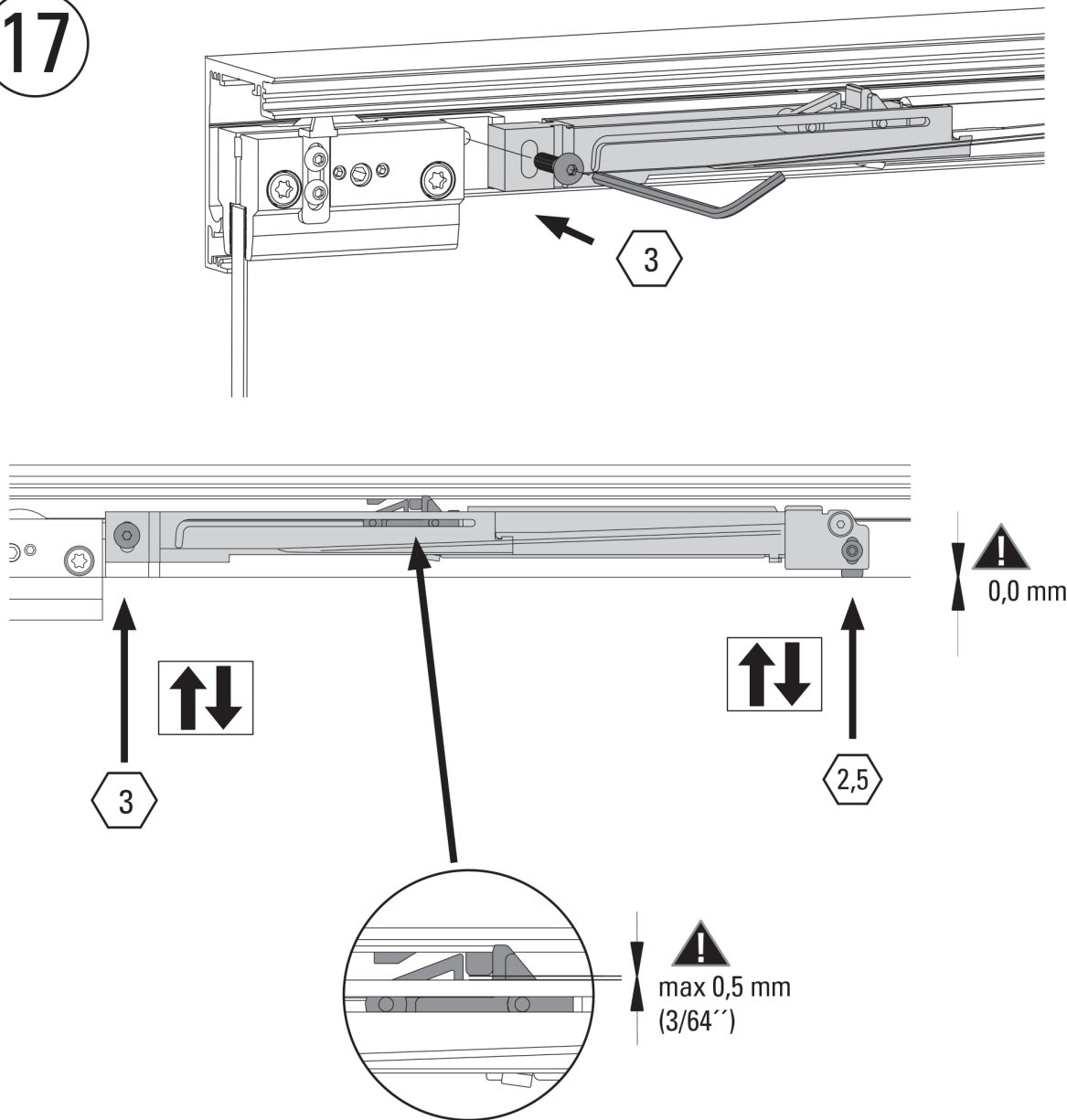

18

