



Direct Doors.com[®]



GLIDEROL
GARAGE DOORS

ROLL-A-GLIDE INSULATED ROLLER DOOR

Installation Instructions

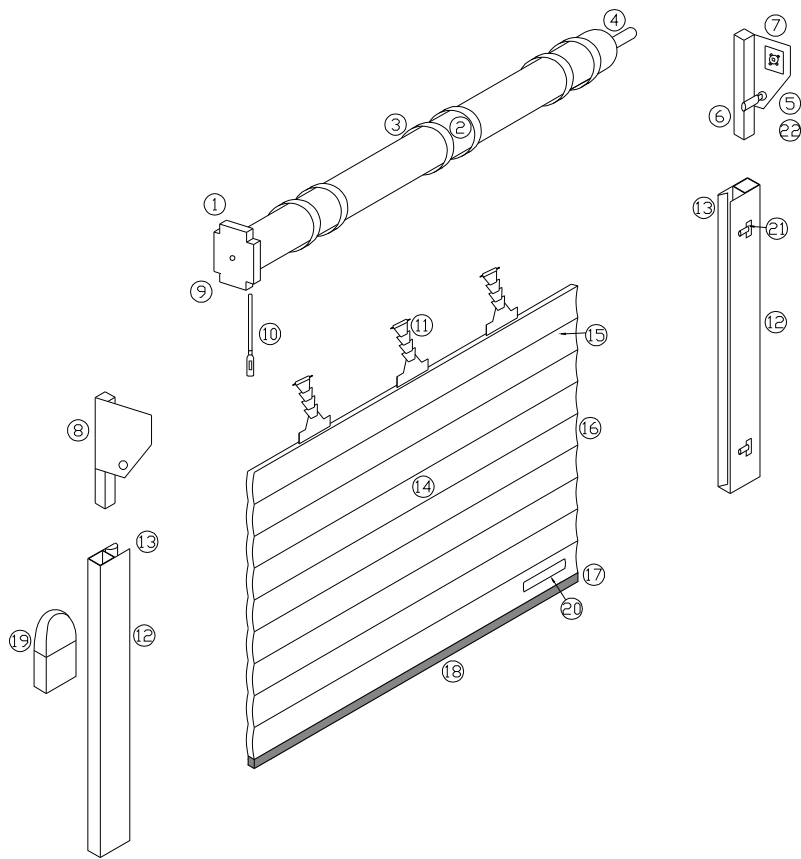

- | | |
|--------------------------|-------------------------------------|
| 1. Motor | 13. Brush Strips |
| 2. Axle Assembly | 14. Curtain Assembly |
| 3. Rigid Link Collars | 15. Door Laths |
| 4. Octagonal Plug End | 16. Locking Caps |
| 5. Shaft Support Bracket | 17. Bottom Lathe |
| 6. Guide Rollers | 18. Rubber Seal |
| 7. R/H End Plate | 19. Control Unit |
| 8. L/H End Plate | 20. Photo Beam Unit (Optional) |
| 9. Override Adapter | 21. Photo Beam Reflector (Optional) |
| 10. Override Eye | 22. Door Transmitter |
| 11. Rigid Links | 23. Safety Stops |
| 12. Guide Rails | 24. Top/Bottom Magnets |
| | 25. Safety Brake |

Pre-installation Checks

Ensure that the site is clear and that all fixing surfaces are sound and free from loose plaster or masonry. Ensure the opening has no irregularities that could damage or mark the optional back box or curtain. Please ensure both walls are parallel before commencing installation.

Unpacking the Door and Guide Rails

The door curtain and guide rails will be fully packaged when delivered.

The guide rails should be unpacked and placed either side of the opening. The guide rails are designed with spacer legs inside to ensure a good fit with the head plate. Ensure that the guides are the correct way round, positioning the spacer legs away from the wall (Fig. 1).

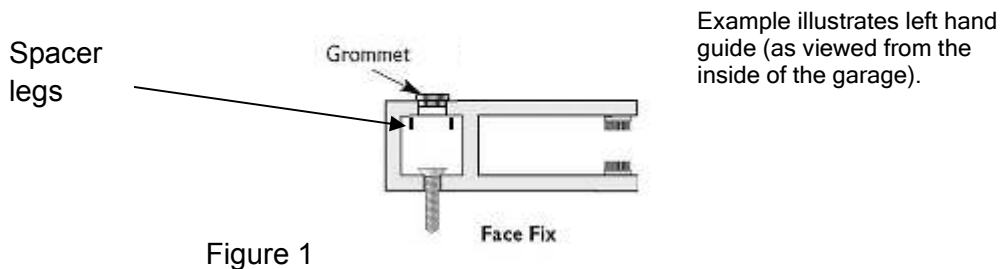

Step 1 - Setting Out Your Installation

If your door is fitted with a back box please move to step 2 as the overall size is pre-set.

If your door does not have an optional back or front box please use these layout instructions. To determine the location of the guide / end plate you must measure the width of the door curtain, not including the plastic end locks. Add 110mm to this measurement to calculate the overall manufactured door width (back of guide to back of guide). Measure the garage door opening and deduct this measurement from the overall width, whatever size is remaining is divided in two and marked on the garage wall as the overall door position.

Step 2 - Preparing the Guide Rails

Drill fixing holes (**7mm**) through the side channel box section starting 150mm from the bottom and evenly space thereafter, your last hole should be 150mm from the top of the guide. Enlarge your fixing hole (**10mm**) on the inside face of the guide section to accept the cover grommets.

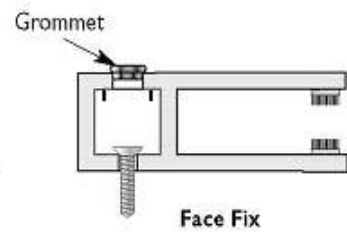
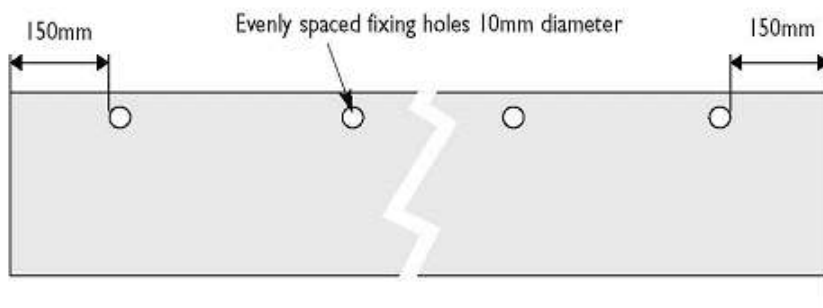

Example illustrates left hand guide (as viewed from the inside of the garage).

Figure 2

Step 3 - Assembling & Fixing the Door Guides & Plates

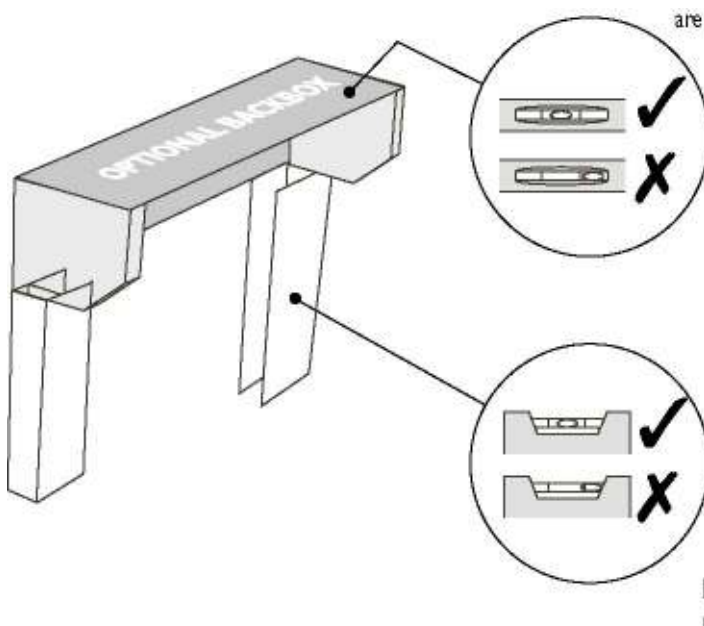

Fit the plate 'peg' into the top of the guide section box and stand the guides upright. Level the guides with the garage opening. Check the vertical guides are level on both sides as well as horizontal across the plates.

Using horizontal (short) edge of level (top edge)

Figure 3

Step 4 - Fixing the Guide Sections

Fix the guides into place using the fixing holes previously drilled ensuring that the guides are vertically plumb and level. Do not over tighten the fixings to compensate for mounting surface distortions, please pack guides if required.

PLEASE ENSURE FIXINGS USED ARE SUITABLE FOR THE GARAGE WALL BUILD PROPERTIES

Step 5 - Fixing the Head Plates

Fix the head-plates into position ensuring that the head-plates are level and that the locating pegs are fully located into the guide section. Fix securing screws through back of head-plate and attached securely to the wall. Where a back box is fitted it may be necessary to fix the back box to the opening header to stop any marking of the curtain during door operation. If additional fixings are required in the back box, use countersunk screws, ensuring that the screw heads do not protrude, as curtain damage could occur.

Always ensure that the back box is adequately fixed to eliminate any rubbing of the curtain on the back box during the door operation.

Step 6 - Motor Barrel Assembly

Once the head plates are in position the motor can now be mounted. The barrel should be lifted and the non motor end inserted into the break device on the head plate first (see Fig. 4a). Then the opposite end of the barrel should then be lined up with the four mounting points on the head plate and secured (see Fig. 4b). Note that the anti-drop break is pre-installed on the head plate on the non motor end of the barrel and the motor adaptor bracket is also pre-installed within the motor. The non motor end of the barrel has an adjustable adaptor which allows the barrel to be decreased in overall length to allow it to fit in between the two head plates.

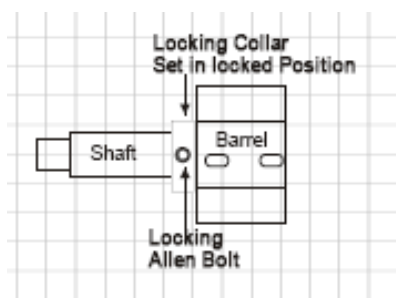

Figure 4a



Figure 4b

Step 7 - Installing the Manual Over-ride

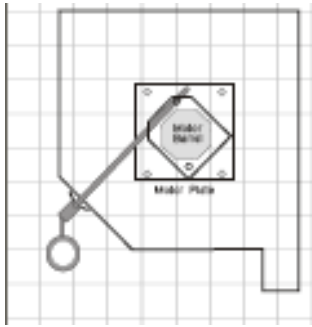

Figure 5

Please note that a notch is required in the head plate to allow the manual over-ride to pass through.

Push manual over-ride adaptor through notch, passing through the over-ride eye on the motor and secure with screw at the top of the motor (Fig. 5).

Step 8 - Mounting and Connecting the Controls

Please see installation instructions supplied with the control box.

Step 9 - Installing the Door Curtain



Figure 6

- (1) The Door curtain is delivered ready rolled for installation with the bottom section to the outside of the roll. To ensure the curtain does not get scratched during installation, the motor barrel metal tube should be covered by cardboard or bubble wrap.
- (2) Lift the curtain rolled and feed the bottom rail over the barrel section into the guides.
- (3) Feed the door into the guides approximately half way. Un-roll the remaining curtain, so the curtain is hanging over the motor barrel (**see Fig. 6**).
- (4) Slide the rigid links onto the top lath of the door curtain (**see Fig. 7**). Carefully slide the door curtain down to the closed position.



Figure 7

Slip the rigid link collars onto the location pegs, ensuring that all pegs are in the same hole series. Secure in place by tightening nut and bolt.

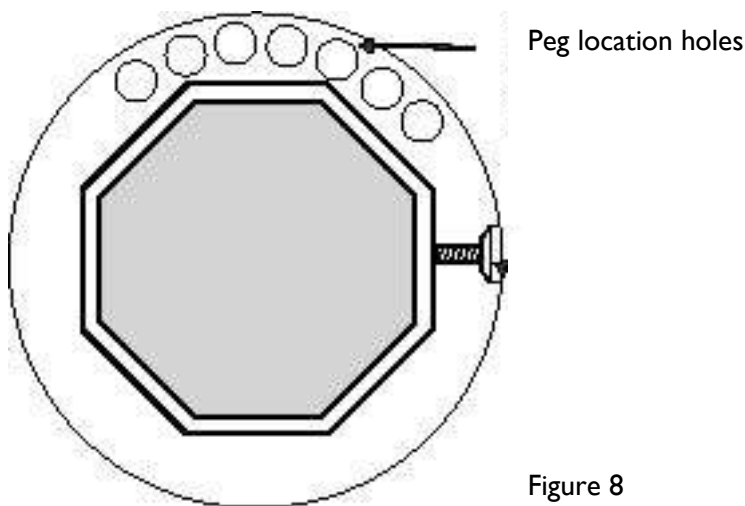

Figure 8

Step 10 - Setting the Motor Travel Limits

The motor limits are a push button system which need to be depressed to initiate the travel stop. The rotation direction of the barrel is relative to the limit switch (see diagrams) Please follow the steps as indicated below.

- 1 Remove limit cover.
- 2 Depress fully both limit switch buttons.
- 3 Ensure rotation is correct with the control unit indication lights for open and close direction.

If not correct please swap the brown and black connections for the tube motor in the control unit

- 4 Close the door to the desired position, the manual over-ride can be used to achieve perfect positioning.
- 5 Depress the corresponding limit button and release. The limit is now set.
- 6 Repeat the process for the top limit position, using the remaining limit button.
- 7 Replace the limit cover, carefully ensuring that the limit switch buttons are not depressed.

NOTE: The motor unit has an inbuilt thermal trip unit which will activate once the motor unit reaches a pre-determined temperature. Repetitive usage during the limit fine adjustment process can cause the motor to cut out. Please wait approximately ten minutes for the unit to return to a normal operating temperature.



Limit Cover in place



Limit to be adjusted

Limit Cover removed

Figure 9

Step 11 - Fitting the Optional Internal Cover

The optional internal cover can only be installed once the limits are fully set.

- (1) Clip the internal cover into the back box top retaining lip at approximately 10 degrees (See Fig 10).
- (2) Once clipped along the entire length of the back box top lip place the internal cover tight to the head plates.
- (3) Drill and fix in place with self tapping screws or pop rivets.
- (4) Drill a hole in the front box to allow the manual over-ride adaptor to pass through and locate into the over-ride eye on the motor unit. Please note that over-ride adaptor should now be stored securely with the crank handle, and not permanently fixed.

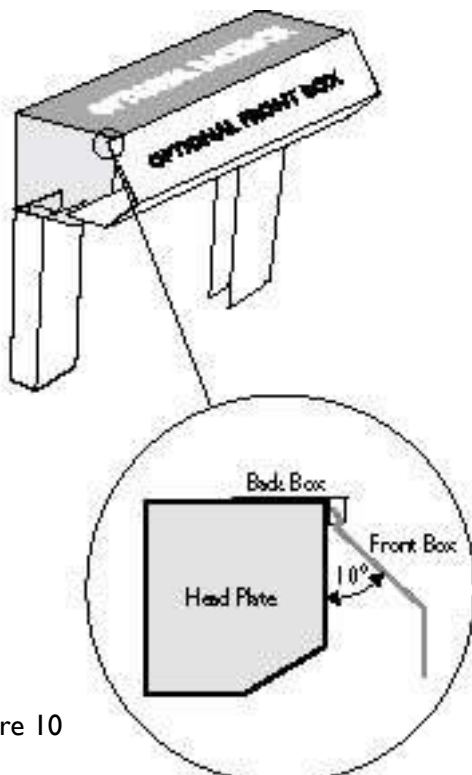

Figure 10

Declaration of Incorporation

SUPPLY OF MACHINERY (SAFETY) REGULATIONS 1992
E.C. DECLARATION OF INCORPORATION
GARAGE DOORS FOR POWERED OPERATION

DOOR TYPE	MAXIMUM WIDTH	MAXIMUM HEIGHT
INSULATED ROLLER DOOR	5400mm	3200mm
COMPACT INSULATED ROLLER DOOR	3800mm	2800mm

Samples of the above doors, at the maximum sizes and weights, have been tested/checked, with regard to suitability for power operation, using Gliderol's powered door-operator types with appropriate safety devices etc., all assembled and installed in accordance with the door/operator installation instructions. These doors were found to conform with EN12453.

The types of doors shown are suitable for use with powered operation unless otherwise declared. They must, however, not be put into service as a power operated door until they have been completely and safely assembled and installed, in accordance with the door and operator manufacturers instructions, with a suitable operator and with appropriate safety devices etc., and not until the complete installation has been declared to be in conformity with the provisions of the appropriate standards.

The Technical Files to cover the Gliderol Garage Doors range of garage doors are held by Gliderol Ltd, and will be made available at the request of an enforcing authority should the need arise.

This Declaration of Incorporation has been prepared by the garage door manufacturer to signify that the accompanying garage door operator, if installed in accordance with the manufacturer's detailed instructions will meet the requirements of EN12453.

It is the responsibility of the installer to ensure that doors and garage door operators are correctly matched prior to installation. It is also the responsibility of the installer, legally described as the Responsible Person, to ensure that a suitably nominated person will confirm that the power operated door has been installed in accordance with the instructions provided by both the door and drive unit manufacturer.

It is also the responsibility of the installing company to check after installation that the power operated door and any safety devices provided are suitable for the application and are all working satisfactorily. This will permit the nominated person to attach a CE label identifying the name of the installing company, a unique door reference number and a date of completion. The installing company should label the door and provide the documentation as specified within EN12635.

One copy of the Declaration of Conformity is to be issued to the client and one copy is to be retained by the installing company, together with the relevant two Declarations of Incorporation. In accordance with the requirements of the Machinery Directive and the UK Supply of Machinery (Safety) Regulations, these records are to be retained on file for a period of ten years.