

manual for the **THORENS** model **TD 124**

transcription  
turntable

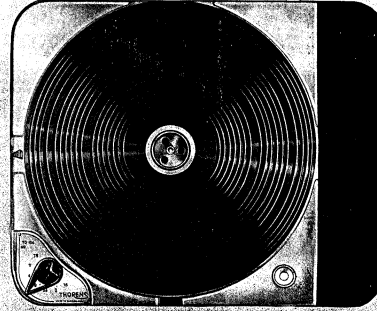

**Congratulations to a new owner of a Thorens turntable**

When purchasing a Swiss-made THORENS Model TD-124 Transcription Turntable, you were not just looking for one more turntable among many others, but you were in search of the finest turntable available, regardless of price.

On our side, we have put all our ability into the design and the manufacture of this outstanding unit to fulfil your highest requirements: the experience of more than a half century in the production of high-quality phonograph equipment, the enthusiasm of a young research team, the traditional pride of our Swiss craftsmen for precision and finely finished work, have been combined to produce the TD-124.

**A few simple rules for installation, operation and maintenance are enclosed in this manual. If you read them carefully, before unpacking the unit, you will be able to immediately benefit by the outstanding performance of this instrument.**

On this condition, we are confident that your TD-124 Turntable will keep our promises and contribute innumerable hours to your enjoyment in the world of music.

Fig. 1 : Controls

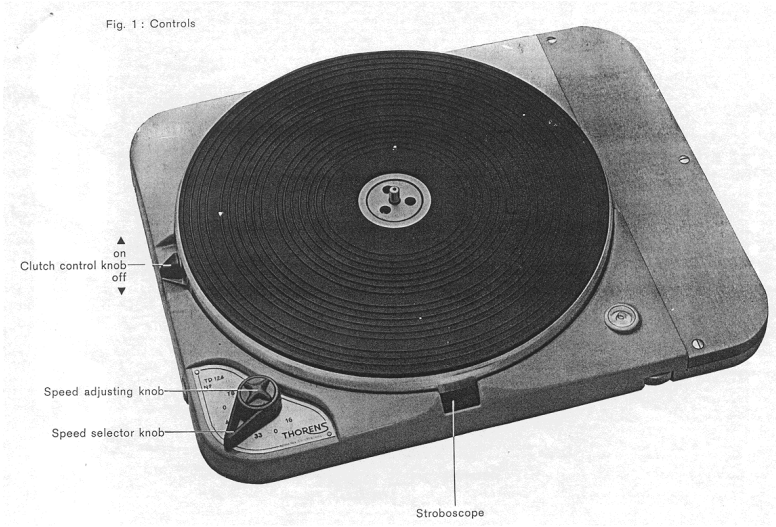

## Unpacking of the TD-124 turntable

1. You have already placed the carton top-side up and opened.
2. Take care that this manual and templates Nos CB 935 and CB 936 are not misplaced.
3. Remove corrugated spacer A.
4. Take the complete unit with the plastic bag B out of the box, holding it by the two shorter sides of the base plate, and place it on the four mounting studs on a table. (Caution : Protect table with cloth or paper.)

Leave the two circular cardboard rings C in position, between the aluminium turntable and the flywheel, and the cylindrical cardboard shipping ring D between flywheel and base plate until the TD-124 is completely installed. The aluminium turntable, being a light precisely machined part, should be protected against any shock, strain or pressure.

5. The plastic bag with mounting hardware is at the bottom of the box.

### IMPORTANT NOTICE

Save the complete packing for possible re-shipment. The TD-124 turntable is a heavy piece of equipment and would be seriously damaged if forwarded in an improvised packing. (Please, see our warranty conditions on the enclosed card.)

2

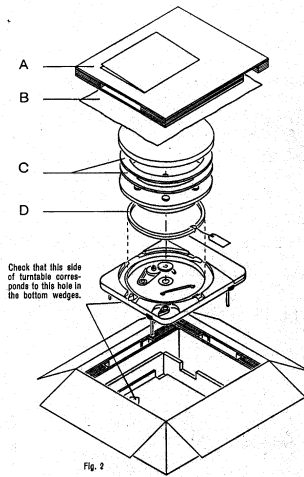

### Notice for packing

After the turntable has been placed into the box according to Fig. 2 and the top cover closed with adhesive paper strips, turn the box upside down and open the bottom cover. Check that all wedges and accessories are in the position corresponding to this illustration.

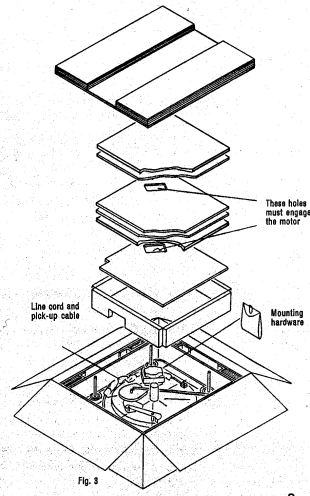

## Installation

### 1 MOUNTING THE PICK-UP ARM

It is advisable to mount the pick-up arm on the wooden board, which is part of the turntable's mechanical design, before installing the unit on a base or panel.

Model PL 104 (USA No AS-12) wooden board, as furnished with each turntable, is dimensioned for 12 inch. pick-up arms. If a 16 inch. arm is to be installed, a PLG 104 (USA No AS-16) board, delivered as an accessory, should be ordered from your dealer. For the SME 3012 pick-up arm, ask for the special CB 910-J wooden board.

It is generally advisable to follow the instructions of the special template No CB 936, furnished with each unit, for mounting the pick-up arm on the corresponding wooden board. Do not fail to follow instructions of tone-arm manufacturer.

### 2 CONNECTING THE PICK-UP

The instructions furnished with each tone-arm and pick-up cartridge should be followed for the connections of these components.

The lug fastened by a screw underneath the frame supporting the wooden board should be used to connect the turntable to the common grounding point for the amplifier. The pick-up arm ground should equally be connected to this lug.

### 3 MOUNTING THE TURNTABLE ON A BASE OR PANEL

If an accessory base was not ordered, the TD-124 turntable should be mounted on a substantial wooden panel (minimum  $\frac{1}{2}$  inch thick, better  $\frac{3}{4}$  inch plywood) which should be cut out and drilled according to template No. CB 935 furnished with each unit. See that sufficient clearance is allowed for the pick-up arm at the rear of the unit.

4

---

The unit mounting board should be fairly level and attached to a perfectly stable cabinet if best results are to be obtained.

### SHOCK MOUNTING

To prevent acoustic feedback and to damp extraneous vibrations, it is strongly recommended to mount the TD-124 turntable on the four rubber dampers furnished, according to the cut view of template No. CB 935. If necessary, additional protection against acoustic feedback and floor vibrations may be obtained by mounting the board freely on thick rubberhair or foam rubber mats. Special steel coil springs (parts CB 1172 and CB 962) are available as accessory upon request, to be used in place of the rubber dampers, for installations where the turntable is submitted to strong extraneous vibrations.

Levelling of the unit should be made by revolving the four knurled knobs protruding from the periphery of the base plate when the bubble of the spirit level is centered, the top surface of the fly-wheel is level.

Tone arms with a levelling device on their base should be finely adjusted after the turntable itself has been levelled.

### IMPORTANT NOTICES

When levelling the turntable, see that the base plate is resting on all four rubber dampers and not mainly on three of them.

Use of washers F 1191 and nuts M 5 VSM 12707 on the four mounting studs is optional. If installed check that substantial play is left between these washers and the unit mounting board after the unit has been levelled, otherwise acoustic feedback may occur.

5

**4 FINAL PREPARATION BEFORE PLAY AND CONNECTING THE MOTOR TO POWER SUPPLY**

According to the tag fixed to the turntable before shipment, proceed as follows :

1. Check that the Speed Selector knob is set on an « O » position.
2. Remove carefully the upper aluminium turntable, protecting it from shock and strain.
3. Remove the flat circular cardboard rings C.
4. Remove the flywheel from its bearing by slowly lifting straight up. Take great care that the spindle and the bearing do not collect any dust, lint or grit, which would be harmful to the most precise adjustment of these parts.
5. Withdraw the cylindrical cardboard ring D from the unit plate.

**6. VOLTAGE COMMUTATOR :**

the commutator allowing instantaneous adaptation to the line voltage is now within reach (Fig. 4). For USA and Canada, the commutator screw has been set at the factory in the position for best results on 110 volts 60 cycles (100-120 volts position) and the commutator protected by an insulating plate that cannot be removed without a tool.

**7. ADJUSTMENT TO THE FREQUENCY OF POWER SUPPLY**

For USA and Canada, the motor pulley and the stroboscope screen have been set at the factory in the position for 60 cycle operation.

According to Fig. 5 and Fig. 6, the adjustment to the frequency of the power supply is made by reversing the motor pulley and the stroboscope screen.

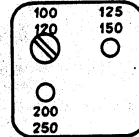

Fig. 4  
Voltage commutator

6

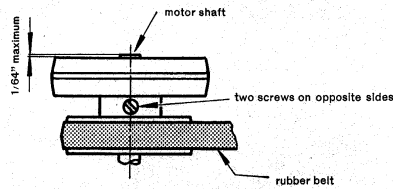

Fig. 5 : Position of motor pulley for 60 cycle operation.

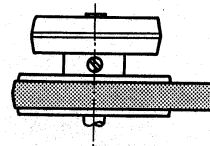

Fig. 6 : Position of motor pulley for 50 cycle operation.

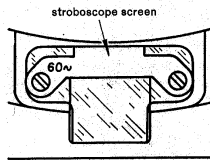

Fig. 7 : Position of stroboscope screen for 60 and 50 cycle operation.

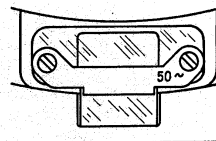

Fig. 8 : Position of stroboscope screen for 50 cycle operation.  
(For European Model with cast iron flywheel only.)

**IMPORTANT NOTICE.** The motor pulley has been dynamically balanced to very close tolerances at the factory. When reassembling it, first tighten the black screw and then the nickel plated one.

7

## 5 REPLACING THE TWO TURNTABLES IN PLAYING POSITION

1. Check that the Speed Selector knob is set on an « O » position.
2. Replace the flywheel into its bearing carefully by maintaining the spindle exactly vertical.
3. Replace the upper aluminium turntable on the flywheel.
4. Connect the turntable line cord to the power supply.

## Operation

### CONTROLS

#### 1. Speed Selector Knob

**78, 45, 33 1/3 rpm position.** When moving the speed selector knob to the desired speed, the motor and the inner flywheel begin to revolve and the stroboscope neon bulb lights up.

**« O » position.** When moving back to an « O » position, the motor and neon bulb are switched off and the idler wheel is disengaged from the pulley and from the inner flywheel. **For this reason, the speed selector knob should always be used to turn off the turntable, and not an external electric switch,** otherwise the rubber tire of the idler wheel could progressively lose its perfectly circular shape and develop noise.

#### 2. Clutch Control Knob

**« Off » position.** When the clutch control knob is in the « Off » position, the upper aluminium turntable is stopped and disengaged from the inner flywheel through a slight lifting movement. The motor and the inner turntable may thus be permanently maintained in operation for the whole time of use of the unit, allowing stable temperature and lubrication conditions for maximum speed regularity.

**« On » position.** When moving the clutch control knob to the « On » position, the upper aluminium turntable is lowered on and engaged by the inner flywheel. The heavy mass of this inner flywheel allows a fast starting of the record. This method of starting eliminates the major cause of wear and deterioration of conventional drive systems.

8

#### 3. Variable Speed Control Knob

The fine speed adjustment knob, coaxially mounted on the Speed Selector knob, allows a most precise adjustment of each of the four nominal speeds over a margin of about  $\pm 3\%$ .

#### 4. Stroboscope

The double stroboscopic pattern on the flywheel corresponds to 60 and 50 cycle operation : at 33 1/3 rpm, the external pattern is for 60 cycle operation and the internal pattern for 50 cycle operation. When adjusted to the nominal speed at 33 1/3 rpm, the three other speeds will be exact within  $\pm 0,3\%$ .

a) The stroboscope of the TD-124 turntable permits control and adjustment of the speed while the record is being played. Thus, for maximum accuracy, the speed should be adjusted while the record is actually playing.

b) During the warm-up period of about 10 minutes the speed may progressively vary a fraction of 1 % about the nominal speed. Though such extremely slow speed variations cannot be detected by the ear, critical transcription work should preferably be made when the motor has reached its normal operating temperature.

9

- c) Owing to the very large scale and high precision of the stroboscope, extremely small differences of speed as compared to the nominal value will be made visible though entirely undetectable by ear.

For example, at 60 cycles a 1 % speed change would appear as a 72 dots per minute drift on the stroboscope. This 1 % variation (or 72 dots) would only vary the pitch  $\frac{1}{6}$  of a semitone. A speed difference of about  $\frac{1}{4}$  of 1 % normally encountered between the beginning and the end of a 12" record, using a modern cartridge with less than 4 grams stylus pressure, will correspond to a 18 dots drift per minute and a pitch variation of  $\frac{1}{24}$  of a semitone, well within NAB Standards.

At 50 cycles, the corresponding number of dots are respectively 60 and 15 each minute.

For special technical work, the speed may easily be maintained constant to the highest accuracy of 0,1 % throughout the playing of a record thanks to the precision speed adjusting device which allows a permanent checking of the speed when the record is actually playing.

- d) Periodical speed variations occurring from one to many times at each revolution of the turntable and designated by wow and flutter, cannot be seen on the stroboscope, being, for the TD-124 turntable, of the order of 0,1 %.

For example, an already very large wow of 0,5 % peak to peak occurring twice each revolution of the turntable would produce a maximum swing of a dot of less than  $\frac{1}{64}$ " (0,37 mm) at 33  $\frac{1}{3}$  rpm and 60 cycles, a value that is beyond the precision of the stroboscope.

10

---

### Summary of the operating instructions

- 1 Move the Speed Selector knob to the desired speed.
- 2 Move the Clutch Control knob to the « Off » position.
- 3 Check the speed on the stroboscope and adjust with the Speed Adjusting knob.
- 4 For large hole records, the built-in adaptor is brought into playing position by pushing down and revolving it.
- 5 Place the record on the turntable.

**Notice.** Records with undersized central hole may exert a slight braking action on the revolving record spindle and a corresponding speed drop on the stroboscope. This will be of no consequence on the final speed when the record is playing.

11

- 6 Move the Clutch Control knob to the « On » position.
- 7 Place the pick-up on the outer non-modulated edge of the record or between two modulated tracks.

#### IMPORTANT NOTICE

If the pick-up is first brought on the non-revolving record, the clutch Control knob should not be roughly pushed to the « On » position, but accompanied by the hand with a sensitive continuous move, otherwise vibrations may be communicated to the unit plate.

- 8 Make the final speed adjustment while the record is playing.
- 9 To stop the turntable for changing the record, move the Clutch Control knob to the « Off » position.
- 10 To stop the motor when the audition is at an end, move the Speed Selector knob to an « O » position.

12

## Maintenance

### I. TURNTABLE SPINDLE

The turntable spindle is revolving on special bushings and on a nylon thrust plate. A sufficient lubricant reserve is foreseen for the whole life of the unit under normal use conditions. If a new lubrication is nevertheless necessary, use **Caltex** or **Texaco Regal Oil B (ROB)**.

**Notice.** If, through inobservance of the instructions of this manual (see p. 8 chap. 4, point 4) dust, lint or grit have been allowed to come inside of the bearing, it should be disassembled from the base plate. To do this, loosen the three screws located on the underside of the base plate, around the bearing. Wash thoroughly both the bearing and the turntable spindle with the recommended oil.

### II. IDLER WHEEL

The bearing of this wheel is of the oil retaining type and rarely needs lubricating. When necessary, introduce two to three drops of ROG oil on top of the bushing, between the stop ring and the wheel. The idler wheel should be perfectly free on its spindle; see that an axial play of about  $\frac{1}{64}$ " is present between the stop ring and the wheel.

**Thanks to the exclusive design of the turntable drive of the TD-124 as well as to the special synthetic rubber tread of the idler wheel the latter will last indefinitely if the complete operating instructions of this manual are followed.**

To remove the stepped pulley and the rubber belt, proceed as follows :

1. Place the speed selector knob on an « O » position. Carefully remove the turntables.
2. Remove the rubber idler wheel from its spindle.
3. Turn the stop plate outside of the stepped pulley.

13



### III. STEPPED PULLEY

The bearing of this pulley is of the oil retaining type and rarely needs lubrication (about every 5000 running hours; no jamming is to be feared). However, on a new unit, a very silent running of this part may sometimes require some more oil than the limited supply that can be safely put into the bearing at the factory (otherwise oil spilling on the drive system could occur during transport). Lift the pulley with its spindle out of the bearing and introduce 4 to 6 drops of our special ROG oil into the well.

### IV. RUBBER BELT

The specially developed synthetic rubber belt running on very large diameter pulleys will not, under normal use, be subject to wear or deformation. Rubber traces on the pulleys should occasionally be taken away with denatured alcohol.

At the same time the slight application of talcum powder on the belt with absorbent cotton will provide a silencing effect.

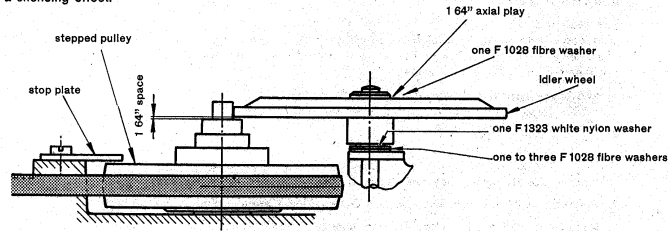

Fig. 9 : Stepped pulley and idler wheel.

14

### V. MOTOR

The motor bearings are of the oil retaining type with large oil reserve in felt pads. Under normal use conditions, the initial lubrication made at the factory should be sufficient for about 5000 hours' run. When the need for a new lubrication becomes apparent, proceed as follows :

#### Upper bearing

Place a few drops of ROB oil on top of the bearing, where the shaft comes out of the top motor shield.

#### Lower bearing

Oil should be put on the lower part of the shaft, underneath the rotor. This lower part can be reached with a pressure oil can through the lubrication hole, on the side of the bottom motor shield.

#### IMPORTANT NOTICE

For a perfect functioning of the drive system of the TD-124 turntable the following parts should be entirely free from any trace of oil or grease on their external working surfaces : the motor pulley, the stepped pulley, the idler wheel, the rubber belt and the inner skirt of the flywheel. Therefore any excess of lubricant may interfere with proper operation. If the presence of oil or grease on the mentioned parts is suspected, they should be thoroughly cleaned with a clean rag impregnated with denatured alcohol.

15

## VI. REPLACING THE NEON STROBOSCOPE BULB

The neon bulb must be replaced from the underside of unit plate :

1. Disconnect unit from AC current.
2. Remove the stroboscope mirror by loosening the mounting spring.
3. Remove the retaining plate.
4. Take out the complete bulb assembly and remove the plastic sleeve.
5. Replace the bulb with type NE 48 or Philips GL 1 W.
6. See Fig. 10 for the exact location of the bulb assembly.

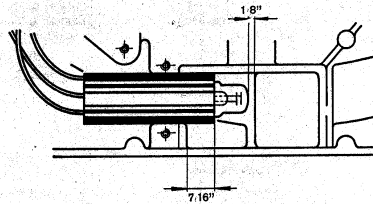

Fig. 10 : Neon bulb.

**Recommended oil.** If the indicated Caltex or Texaco Regal Oil B (as used for hydraulic power transmissions) is not available, use a non-oxidizing, non sticking, high-grade light mineral oil (SAE 20). A lubrication kit with recommended lubricants is available as accessory upon request.

16

### Our warranty is granted under the following conditions :

1. Complete the information on the enclosed warranty card and return it within 10 days after purchase to the Thorens General Representative, the address of which will be given by your dealer.
2. **Before returning your turntable for inspection or repair**, write to the General Representative for permission to receive replacement parts or to return the complete unit to the nearest authorized service station. State Model number and Serial number of unit. Describe completely the defective operation and list the associated equipment.
3. After permission to return the unit is received, **pack it in the original carton according to the instructions of the manual, without accessory base**. Any pick-up arm, with the exception of the original Thorens Models specially designed for the TD 124 Turntable, should be removed with their wooden mounting pannel. For Thorens pick-up arms, remove the counterweight together with the tubular arm extension and the plug-in shell, and pack them separately. Shipment **MUST** be made shipping charges prepaid.
4. Any damage caused by failure to observe the instructions for packing, installation, operation and maintenance as contained in the manual furnished with each unit, by accident in transit or elsewhere, will not be covered by this warranty.
5. This warranty is not extended to units which have been repaired or altered by anyone other than an authorized service station.
6. The unit will be returned shipping charges collect. This warranty is in lieu of all others, expressed or implied.