

PS-X800

AEP Model
E Model
UK Model
Canadian Model
US Model



STEREO TURNTABLE SYSTEM

SPECIFICATIONS

Turntable

Platter	32 cm (12 $\frac{3}{8}$ in.), aluminum-alloy diecast
Motor	Linear torque BSL (brushless and slotless) motor
Drive system	Direct drive
Control system	Quartz lock control, magnedisc servo control system
Speed	33 $\frac{1}{3}$ rpm, 45 rpm
Starting characteristics	Comes to nominal speed within a half revolution (33 $\frac{1}{3}$ rpm)
Wow and flutter	0.015% (WRMS)* 0.025% (WRMS) $\pm 0.03\%$ (DIN)
Signal-to-noise ratio	78 dB (DIN-B)
Load characteristics	0% up to 150 g stylus force (at lead-in groove of a record)
Speed deviation	Within 0.003%
Automatic system	Lead-in, return, reject, repeat, record size selection, zero balance

Tonearm

Type	Electronic tonearm, linear tracking
Pivot-to-stylus length	180 mm (7 $\frac{1}{8}$ in.)
Overall arm length	246 mm (9 $\frac{3}{4}$ in.)
Tracking error	$\pm 0.05^\circ$

Stylus force adjustment range	0.5 - 3.0 g (electronic adjustment)
Cartridge shell weight	7.2 g
Cartridge weight range (including a cartridge shell)	10 - 17 g 16 - 23 g (with thin extra weight) 22 - 29 g (with thick extra weight)

— Continued on next page. —

ATTENTION AU COMPOSANT AYANT RAPPORT
À LA SÉCURITÉ!

LES COMPOSANTS IDENTIFIÉS PAR UNE TRAME ET UNE MARQUE  SUR LES DIAGRAMMES SCHÉMATIQUES, LES VUES EXPLOSÉES ET LA LISTE DES PIÈCES SONT CRITIQUES POUR LA SÉCURITÉ DE FONCTIONNEMENT. NE REMPLACER CES COMPOSANTS QUE PAR DES PIÈCES SONY DONT LES NUMÉROS SONT DONNÉS DANS CE MANUEL OU DANS LES SUPPLÉMENTS PUBLIÉS PAR SONY.

SAFETY-RELATED COMPONENT WARNING!!

COMPONENTS IDENTIFIED BY SHADING AND MARK  ON THE SCHEMATIC DIAGRAMS, EXPLODED VIEWS AND IN THE PARTS LIST ARE CRITICAL TO SAFE OPERATION. REPLACE THESE COMPONENTS WITH SONY PARTS WHOSE PART NUMBERS APPEAR AS SHOWN IN THIS MANUAL OR IN SUPPLEMENTS PUBLISHED BY SONY.



MICROFILM

SONY

SERVICE MANUAL

PS-X800

General

Power requirements	AEP model: 220 V ac, 50/60 Hz UK model: 240 V ac, 50/60 Hz E model: 110–120 V or 220–240 V ac adjustable, 50/60 Hz US, Canadian model: 120 V ac, 60 Hz
Power consumption	45 W
Dimensions	Approx. 440 x 120 x 445 (w/h/d) (17 $\frac{3}{8}$ x 4 $\frac{3}{4}$ x 17 $\frac{5}{8}$ in.) including projecting parts and controls
Weight	Approx. 11.6 kg (25 lbs 10 oz), net Approx. 13.0 kg (28 lbs 10 oz), in shipping carton

* This new measuring method concerns only the turntable assembly, including the platter. It excludes wow and flutter caused by the tonearm, the cartridge, or the record. Measured by obtaining signal from magnetic pick up head.

MODEL IDENTIFICATION

— Specification Label —

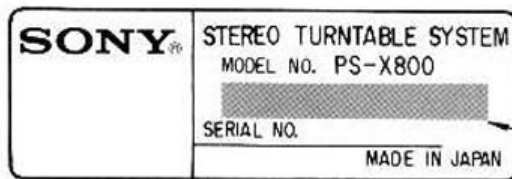

US, Canadian model:

AC 120 V 60 Hz 45W

AEP model:

AC 220 V ~50/60 Hz 45W

UK model:

AC 240 V ~50/60 Hz 45W

E model:

AC 110 – 120, 220 – 240 V ~50/60 Hz 45W

Handling Precautions for MOS ICs

Generally, the insulation resistance of the oxide layer in MOS IC structures is very high, and the oxide layer is very thin. Because of this, it is possible that the static voltages usually present on clothes and the human body will be enough to generate a potential difference across the insulator, high enough to cause a breakdown of the insulating layer.

The following precautions should be taken while handling these ICs.

(Particular care should be taken under conditions of low humidity.)

Precautions in Replacing MOS ICs

1. Store new ICs by inserting them into a urethane-polyester cushion (which is somewhat conductive), or wrapping it in aluminum foil, so that all the pins are at the same potential. (The ICs should be stored in that manner until mounted on the circuit board.)

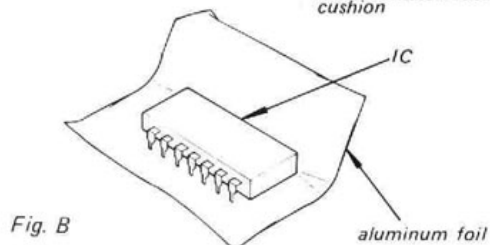
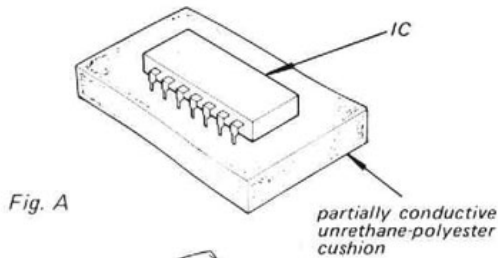

2. Check the soldering iron for possible power-line leakage current. Make sure that there is no leakage path by connecting an ohmmeter to the tip of the soldering iron and the plug as shown in Fig. C. If there is a leakage path, use some other soldering iron.

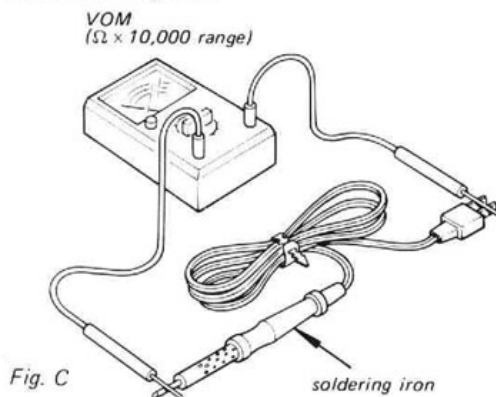

3. Equalize any potential difference between the clothes, the tools in use, the work bench, the set being worked on, and the packaged IC by touching them all in succession with the hands or a conductive wire or tool.
4. The following are effective methods for handling ICs that remove the potential difference across the oxide layer.
 - Use a paper clip modified by soldering in a wire braid insert.

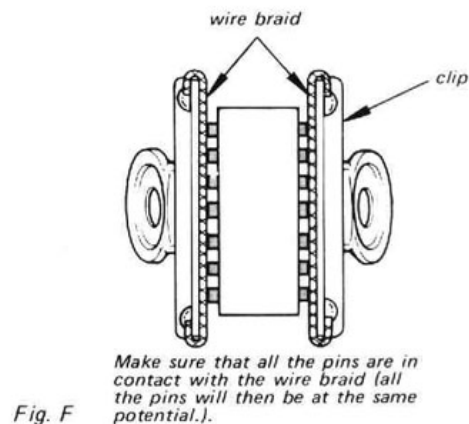
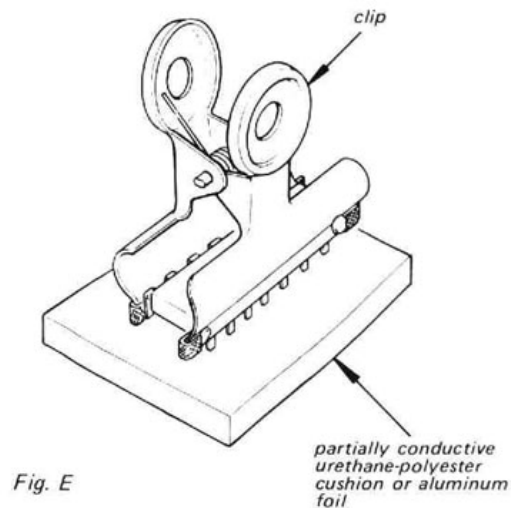
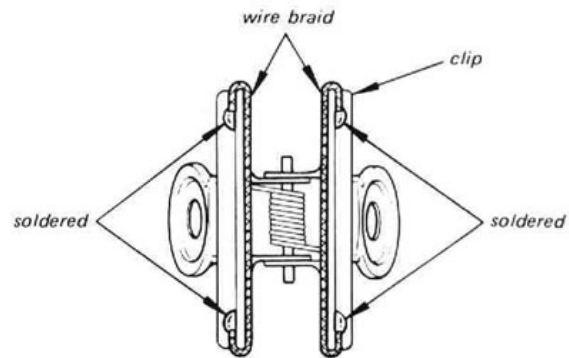

- Take a short length of fine bare wire and wind it around the IC so that it shorts all the pins of the IC, while it is still in the urethane-polyester cushion or aluminum foil. This ensures that all the pins are at the same potential.

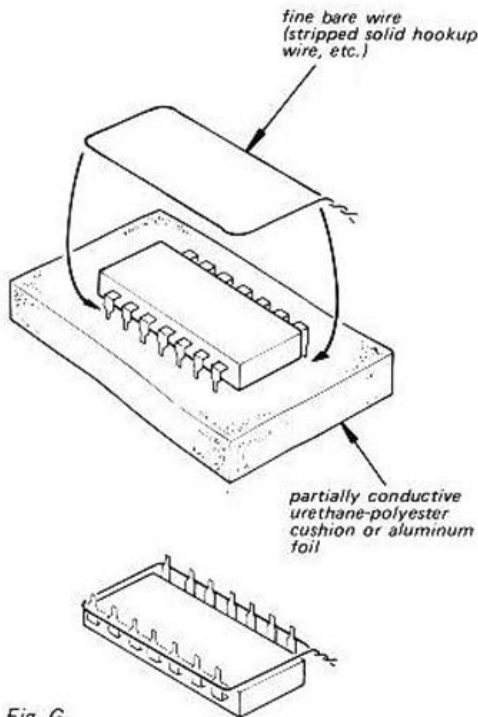

Fig. G

- When it is necessary to handle the IC with the fingers, do not touch any pin, and hold the IC at the ends of its plastic-package case as shown in Fig. H.

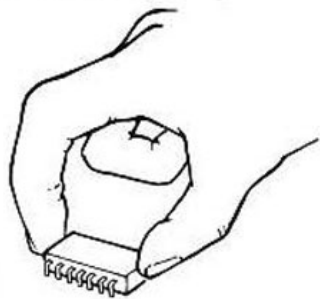

Fig. H

Method of Mounting

Insert the IC while holding it with the modified clip, and solder all the pins with the clip still shorting the pins. (Similarly, solder all the pins while the bare shorting wire is still wound around them.). Remove the clip or the bare shorting wire only after all the pins have been soldered.

Precaution while Checking C-MOS ICs

The C-MOS ICs (Complementary MOS) are MOS ICs that have their output sections made up of N-channel and P-channel push-pull stages to increase their speed of operation. If the output terminal of these ICs comes into contact with B+ or B- voltage, then the FET which is ON at that time will either become shorted or open.

This is valid for all the output sections that are connected together by the interconnections. Even the circuits that are physically separated (and not on the same board) can be destroyed simultaneously.

Example:

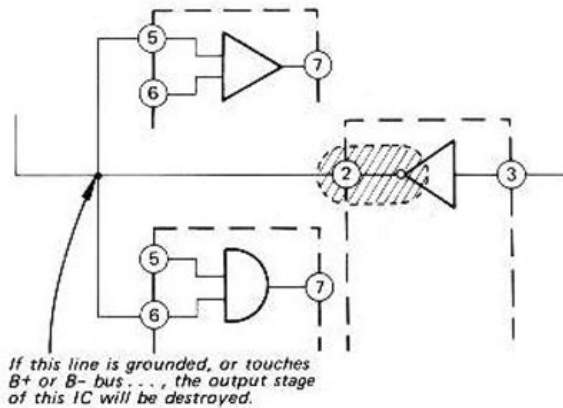
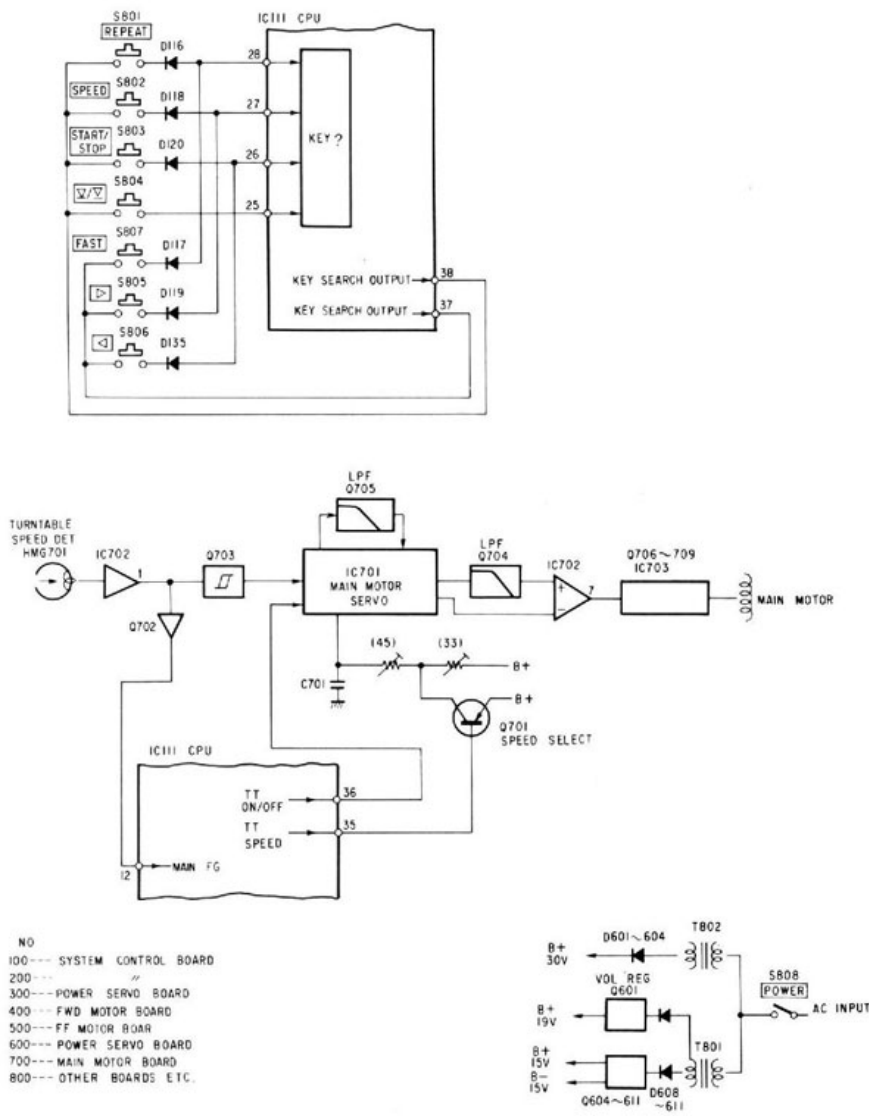

Fig. I

SECTION 1
OUTLINE

1-1. BLOCK DIAGRAM



PS-X800

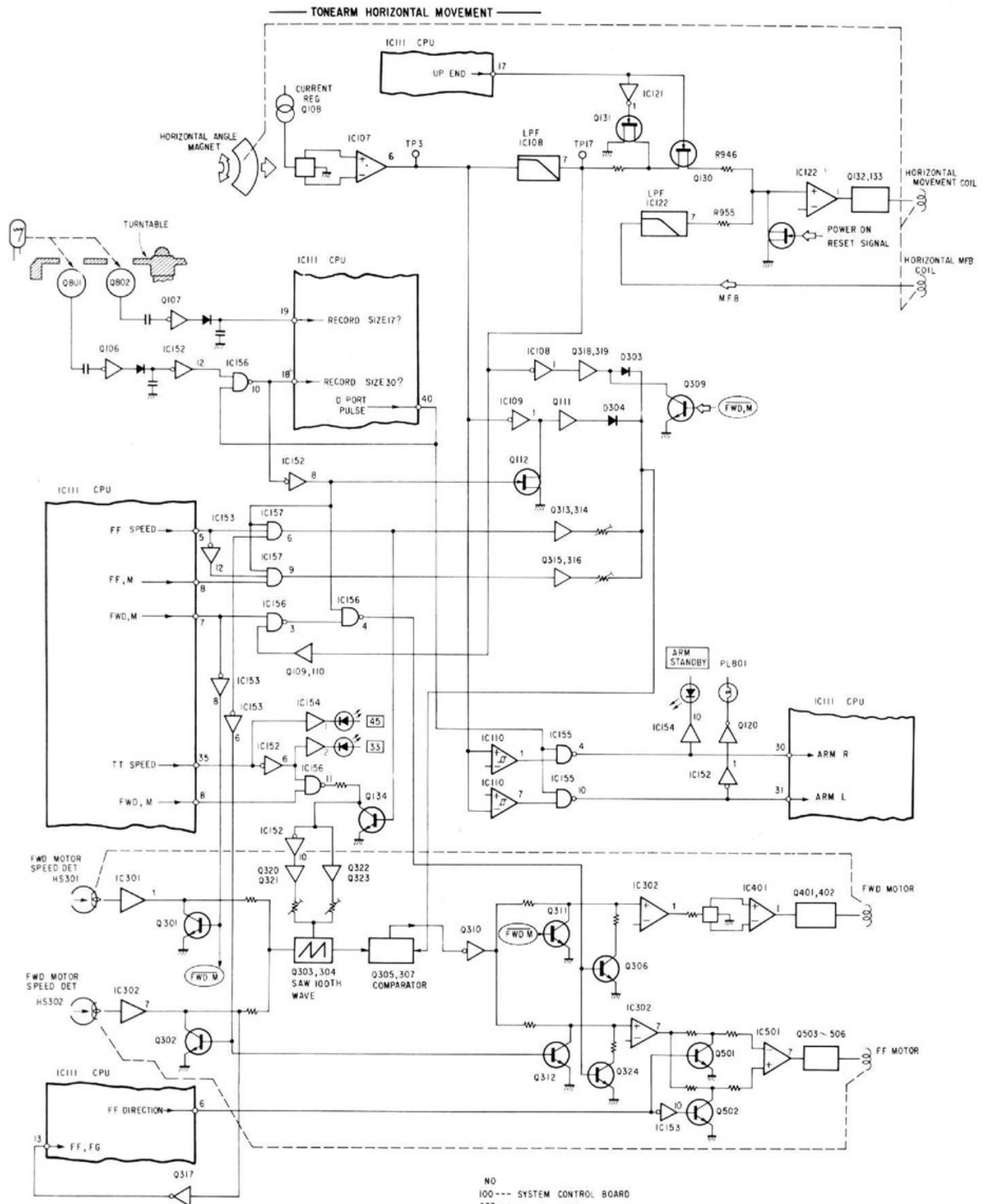

- NO
- 100 --- SYSTEM CONTROL BOARD
- 200 --- "
- 300 --- POWER SERVO BOARD
- 400 --- FWD MOTOR BOARD
- 500 --- FF MOTOR BOARD
- 600 --- POWER SERVO BOARD
- 700 --- MAIN MOTOR BOARD
- 800 --- OTHER BOARDS ETC.

— TONEARM VERTICAL MOVEMENT —

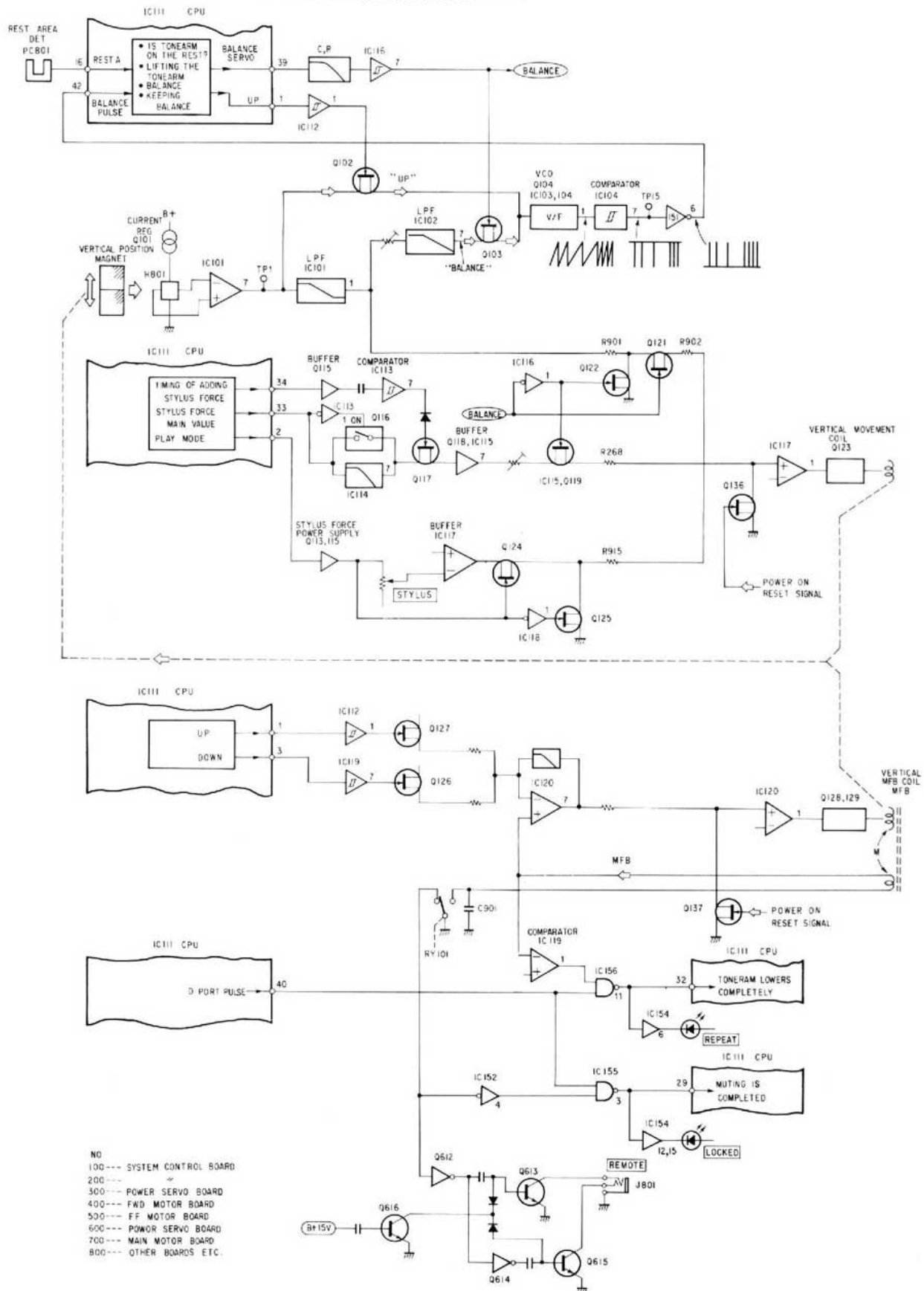

1-2. OUTLINE

RECORD PLAYING—Auto play

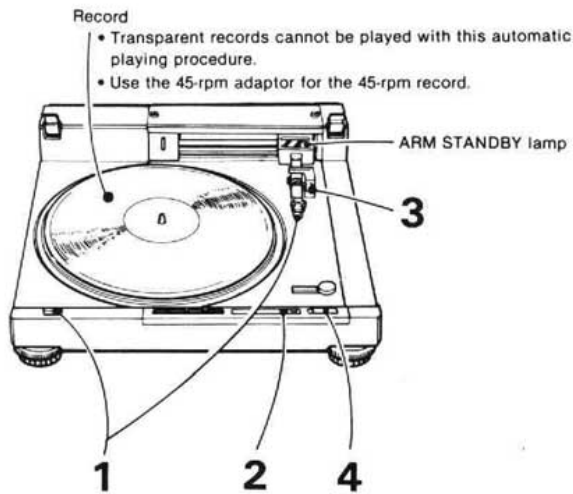

- 1 Remove the stylus cover and depress the POWER switch (ON).
- 2 Press the SPEED selector to play a 45-rpm record. (Press this again for a 33 $\frac{1}{3}$ rpm record.)
- 3 Depress the lever and release the clamp of the arm rest. The ARM STANDBY lamp is turned off when the tonearm balance adjustment is finished.



- 4 Press the START/STOP button and the record playing will begin.

When the tonearm reaches the end of the record, the turntable will stop and the tonearm will automatically return to the arm rest. Secure the tonearm to the arm rest and turn the POWER switch off.

Tonearm auto-balance adjustment

It is critically important for good sound reproduction that the stylus traces the record groove accurately and with the proper stylus force. To do this, the tonearm must first be balanced so that the proper stylus force can be applied. The Sony PS-X800 turntable automatically adjusts the tonearm balance electronically when the power is turned on or the START/STOP button is pressed with the tonearm secured to the arm rest. And every time the record playing is finished, the tonearm balance is automatically adjusted again. The ARM STANDBY lamp illuminates when tonearm balance is being adjusted.

When the cartridge shell (or cartridge) is replaced, secure the tonearm to the arm rest and turn the POWER switch off. To adjust the balance of the new cartridge shell (or cartridge), remove the stylus cover and turn the POWER switch on. When the ARM STANDBY lamp turns off, the adjustment is complete.

TO BEGIN RECORD PLAY AT A PARTICULAR POINT

- 1 Remove the stylus cover and depress the POWER switch (ON).
- 2 Press the SPEED selector to play a 45-rpm record. (Press the selector again for a 33 $\frac{1}{3}$ rpm record.)
- 3 Release the arm rest clamp. The ARM STANDBY lamp is turned off when the tonearm balance adjustment is finished.
- 4 Move the tonearm over the record, pressing the ◀ button and the FAST button. For fine adjustments, press and immediately release the ◀ button or the ▶ button or push the tonearm slightly.

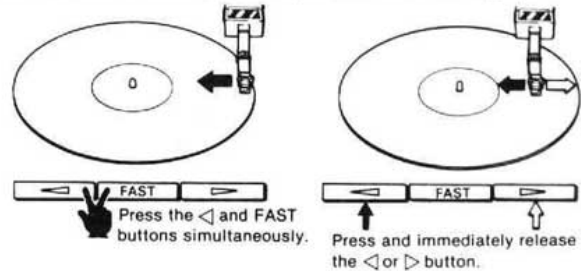

- 5 Press the START/STOP button, and the record playing will begin.

CARTRIDGE INSTALLATION AND STYLUS FORCE ADJUSTMENT

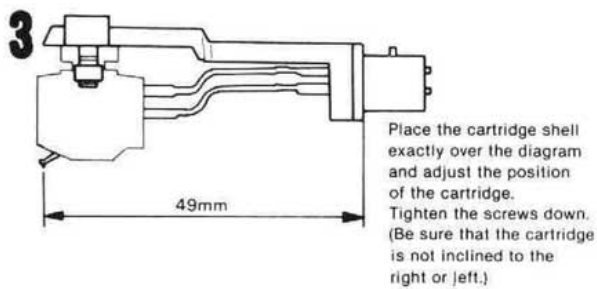
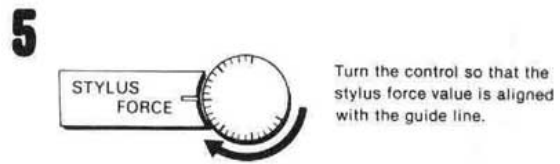
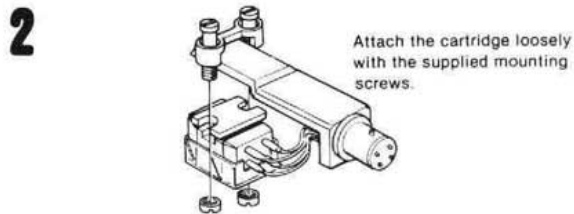
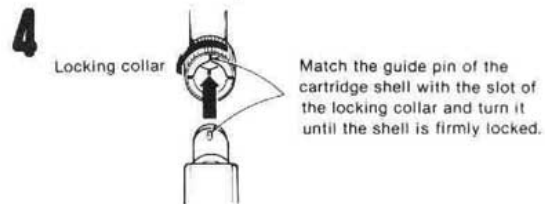
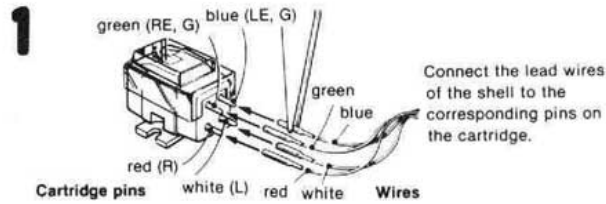

On installation of the extra weight

The extra weight is not needed when the cartridge weight (including the supplied 7.2 g shell) is between 10 and 17 g. Install the thin extra weight if the cartridge weight is between 16 and 23 g and the thick extra weight if between 22 and 29 g.

Remove the screws and the arm cover.

Extra weight

Replace the arm cover and tighten the screws firmly.

CONNECTION TO AN AMPLIFIER

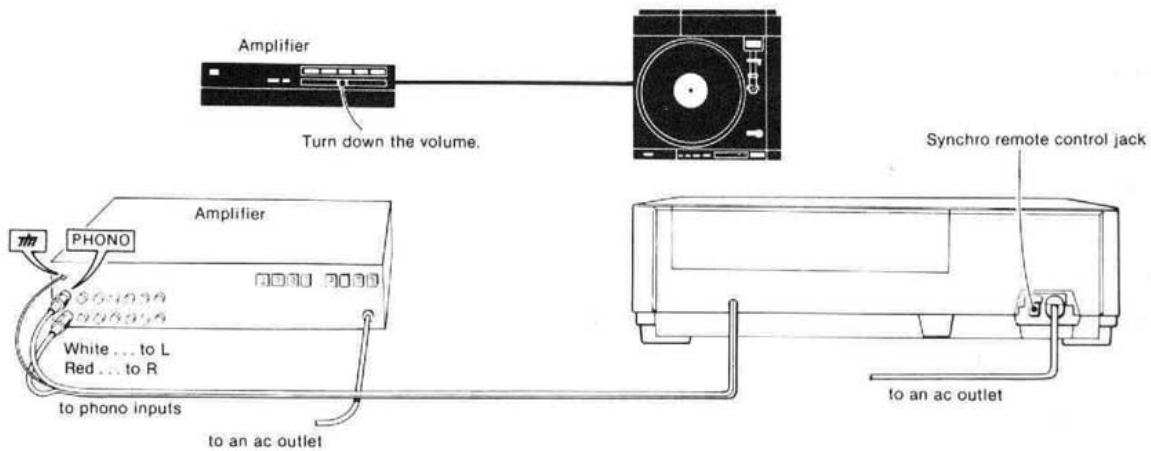

TROUBLE CHECKS

The following trouble checks will help you correct most common problems encountered with a turntable system. Should any problem persist after you have made these checks, consult your nearest

Sony service facility.

Before proceeding with these trouble checks, first refer to the connections on page 9 and the operating procedures on page 8.

TROUBLES	CAUSES	WHAT TO DO
The tonearm does not lower on the record but returns to the arm rest.	<ul style="list-style-type: none"> Transparent record Warped record 	<ul style="list-style-type: none"> Play the record manually.
The ARM STANDBY lamp does not go out.	<ul style="list-style-type: none"> The cartridge and the cartridge shell are too heavy (or too light.) The tonearm is secured to the arm rest. 	<ul style="list-style-type: none"> Check the cartridge (including the cartridge shell) weight. Release the arm rest cramp.
The tonearm always lowers on the point for 30 cm records.	<ul style="list-style-type: none"> A rubber mat other than the one supplied being used. Incorrect placement of the supplied rubber mat 	<ul style="list-style-type: none"> Use the supplied rubber mat. Align the holes in the rubber mat with the holes of the platter.
Auto return does not operate at the end of play.	<ul style="list-style-type: none"> A record with shallow return grooves being played by a cartridge with low tracking force 	<ul style="list-style-type: none"> Apply more tracking-force.
Impaired tone quality	<ul style="list-style-type: none"> Improper tracking-force Dusty stylus Worn stylus 	<ul style="list-style-type: none"> Apply proper tracking-force (See page 9.) Clean the stylus with a soft brush from back to front. The stylus life is approx. 400 hours. Replace with a new stylus.
No audio from one channel	<ul style="list-style-type: none"> Loose connection of phono cord Loose attachment of the cartridge shell to the tonearm Dirty cartridge shell terminals. 	<ul style="list-style-type: none"> Connect the cord firmly. Fix the shell to the tonearm firmly. Clean the terminals with a soft dry cloth.
Steady low-pitched humming sound	<ul style="list-style-type: none"> Ground wire is not connected to the amplifier. 	<ul style="list-style-type: none"> Connect the ground wire to the amplifier.
Groove skipping ; tonearm skating ; tonearm not advancing.	<ul style="list-style-type: none"> Improper tracking force Turntable not level Defective record 	<ul style="list-style-type: none"> Apply proper tracking-force. (See page 9.) Place the turntable on a level surface.
Loud rumble or low-frequency howl*	<ul style="list-style-type: none"> The turntable is subjected to external vibration. The turntable is placed too near the speaker. 	<ul style="list-style-type: none"> Place the turntable on a solid surface free from external vibration. Locate the turntable as far away from the speaker as possible.

* This is called "acoustic feedback" and is caused when vibrations from the speakers are transmitted through the air or via solid objects (such as the shelves, the cabinet, the floor, etc.) to the turntable, where it is picked up by the stylus, amplified and reproduced through the speakers once again.

SECTION 2
DISASSEMBLY

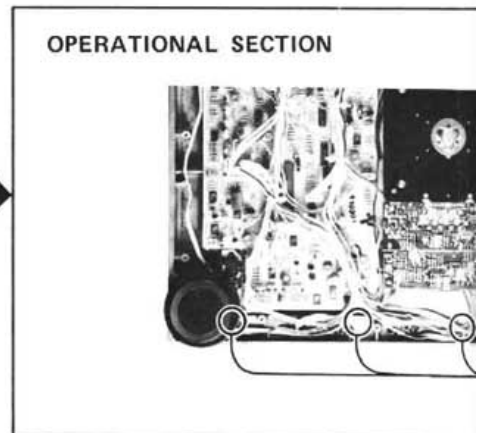
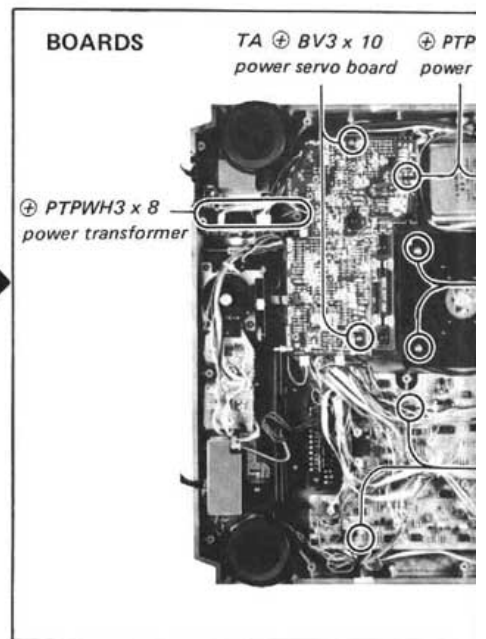
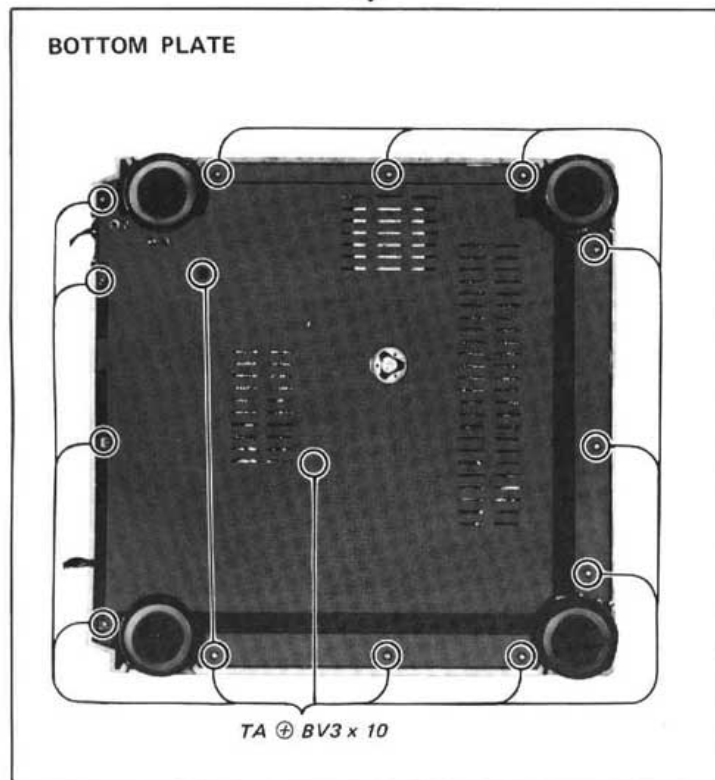
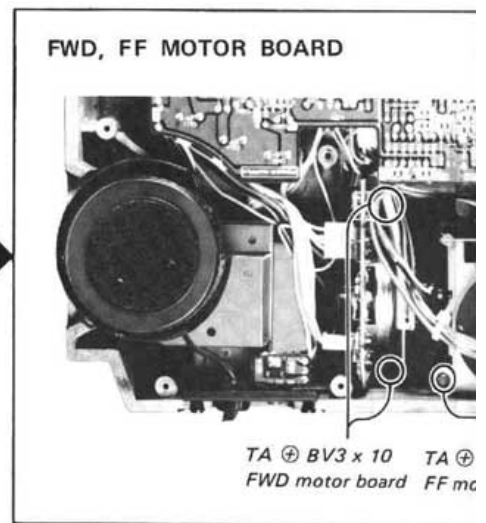
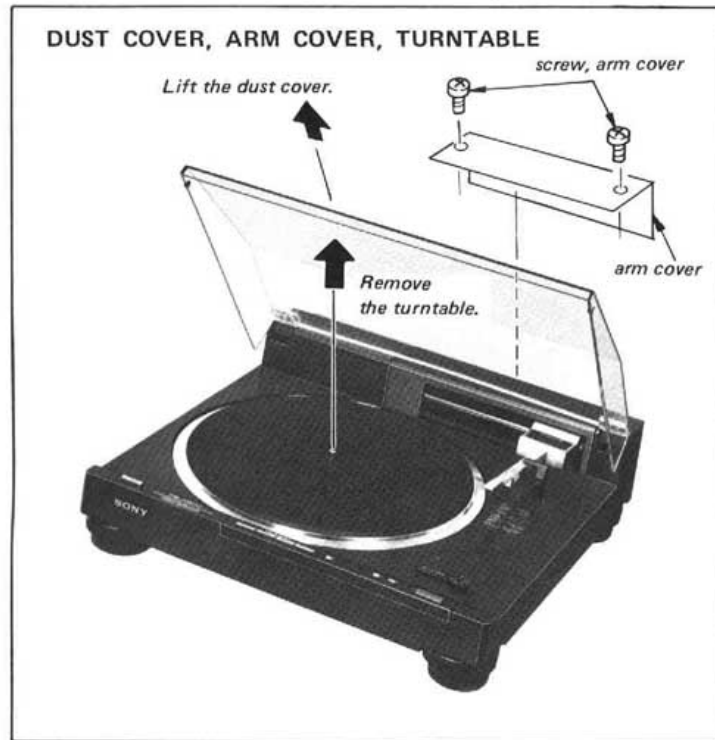

RD

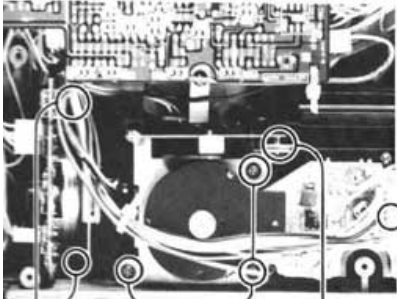

3V3 x 10 TA ⊕ BV3 x 10
otor board FF motor board

Remove the canoe clip.
Remove the string.

TONEARM Remove lead wires.

Unsolder boards A - H .

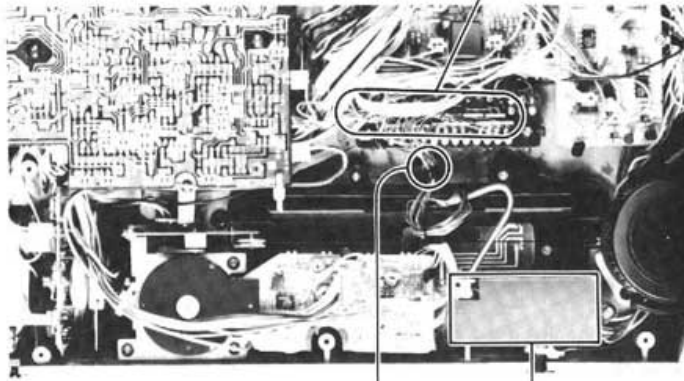

Remove lead clamp. Remove lead wires of cartridge from the phono board.

V3 x 10 ⊕ PTPWH3 x 18
rva board power transformer

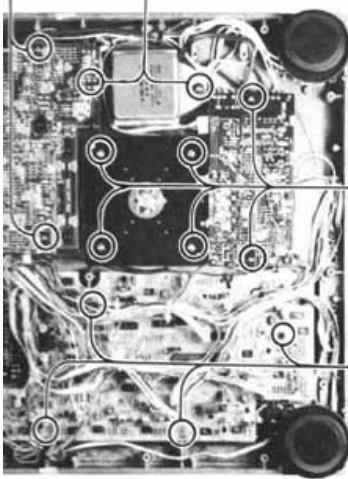

TA ⊕ BV4 x 12
TA ⊕ BV3 x 10
main motor board

TA ⊕ BV3 x 10
system control board

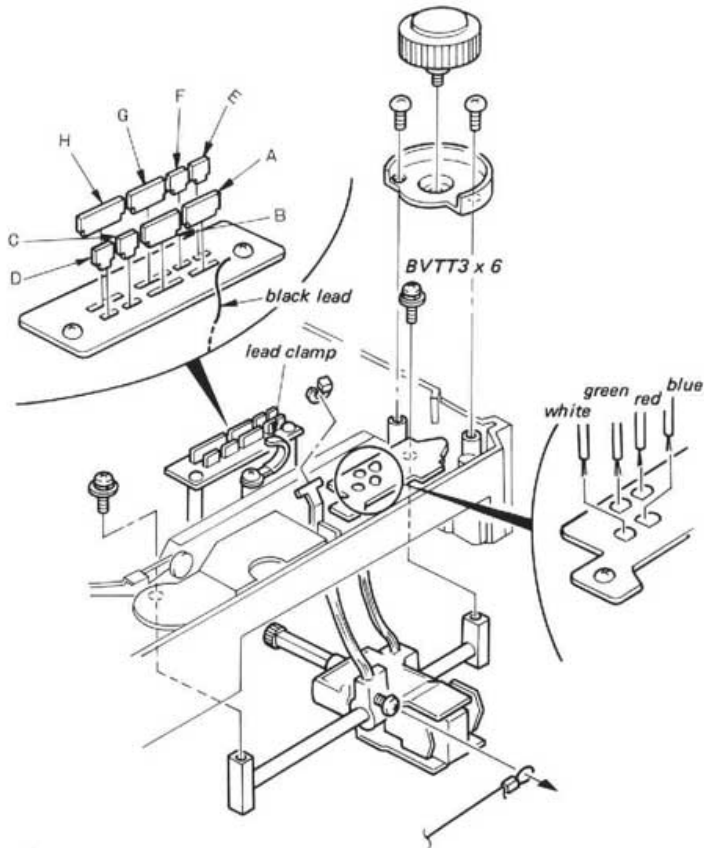

N

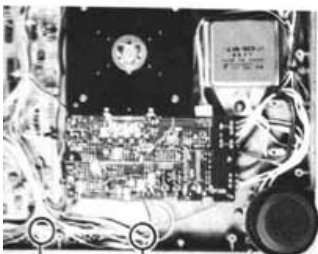

PSW3 x 25
operational section

Remove the cover, wire and tonearm:

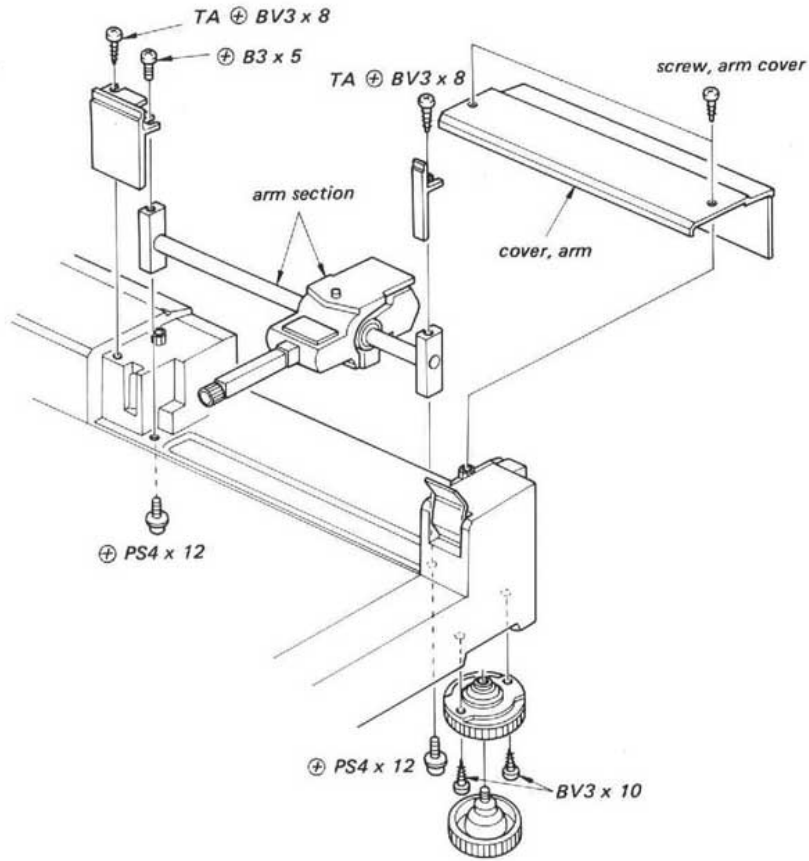

Remove wires and fix them with scotch tape.

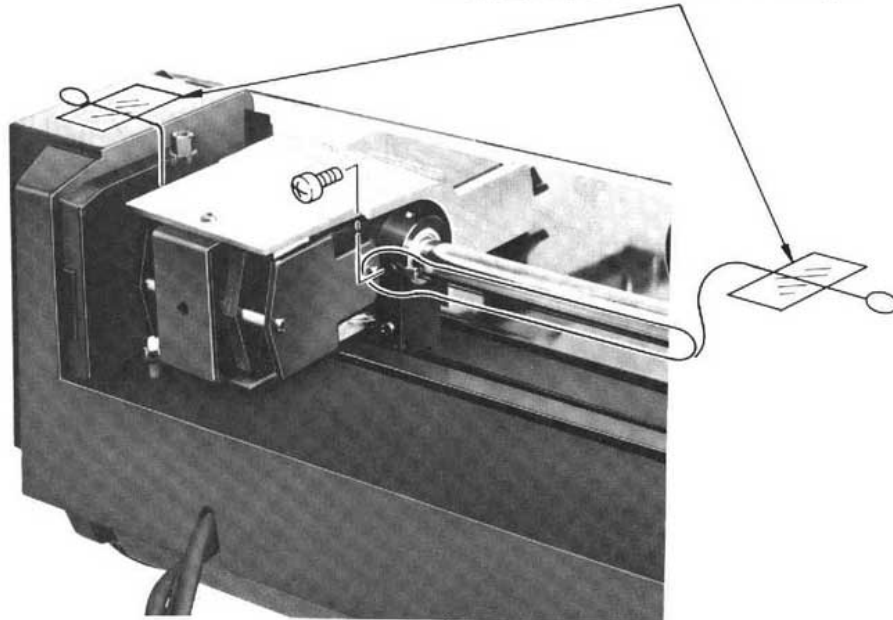

Remove inner section of the tonearm.

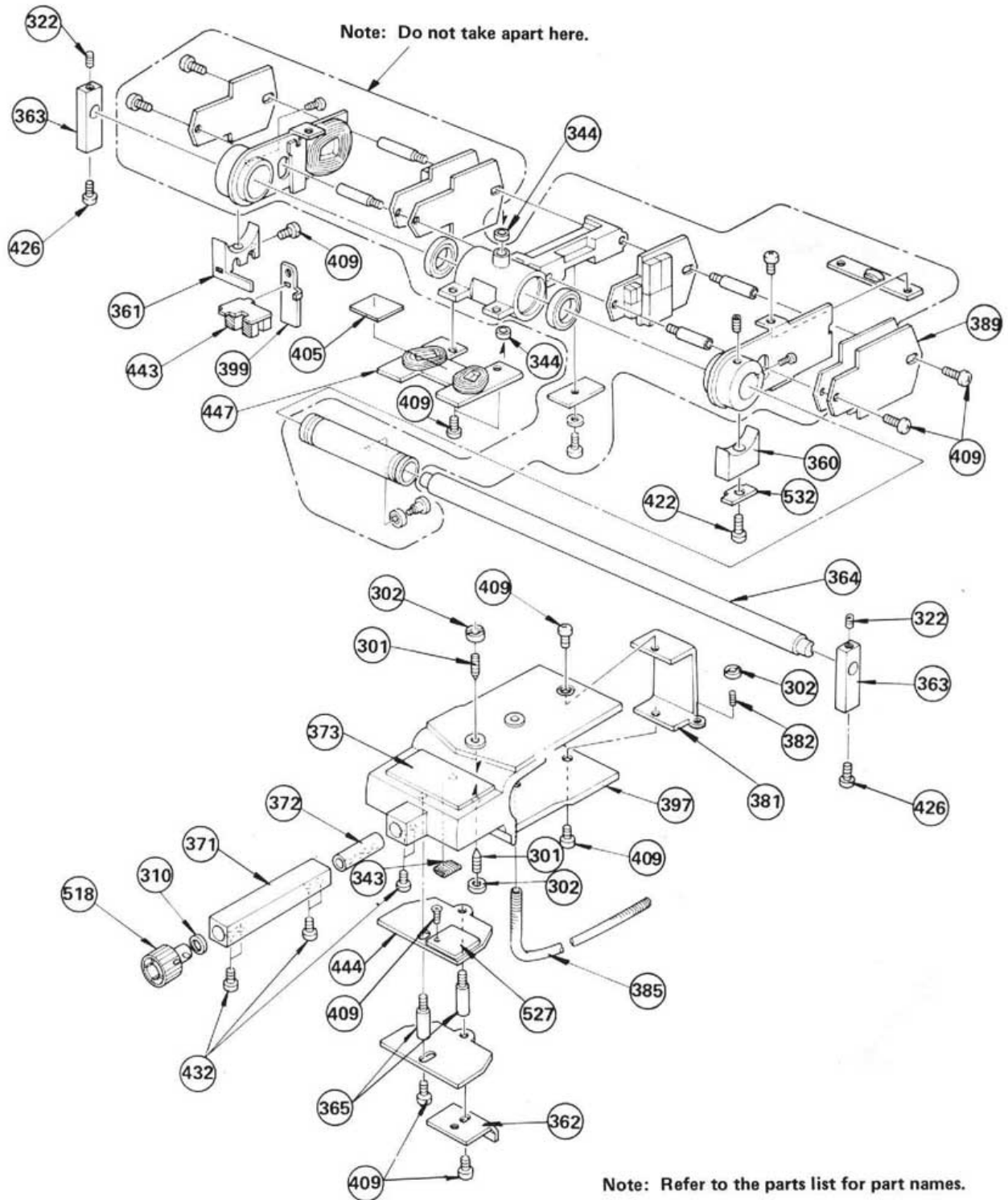

HOW TO STRING THE WIRE

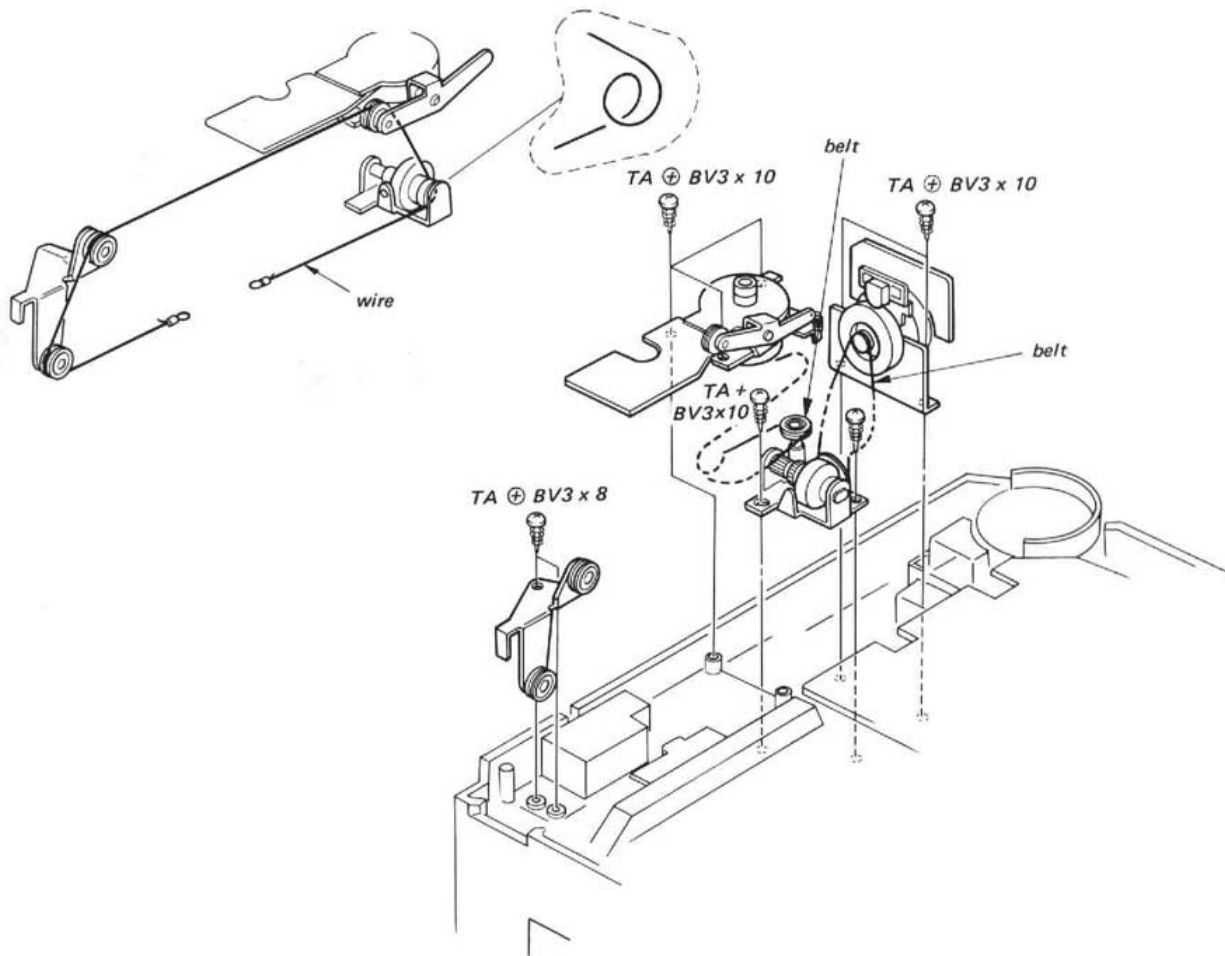

SECTION 3
ADJUSTMENTS

Output Level Adjustment for Speed Detecting Head of Main Motor

Setting:

POWER Switch: ON
SPEED Selector: 33 1/3 rpm

1. Rotate the turntable and adjust the position of the head by loosening the screw so that the voltage at the output terminal of the head is between 30 – 60mV ac.

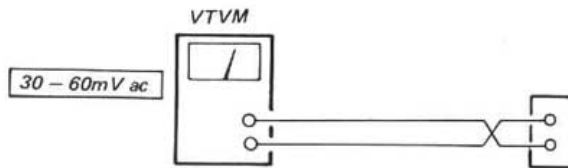

2. Make sure that the head does not touch the turntable.

Note: The clearance between the magnet coated rim and the speed detecting head should be more than 0.3mm to avoid wow and flutter.

speed detecting head TA, BV3 x 10

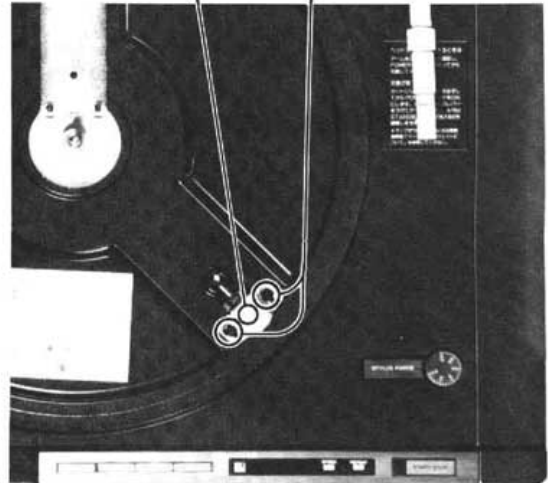

— with the turntable removed —

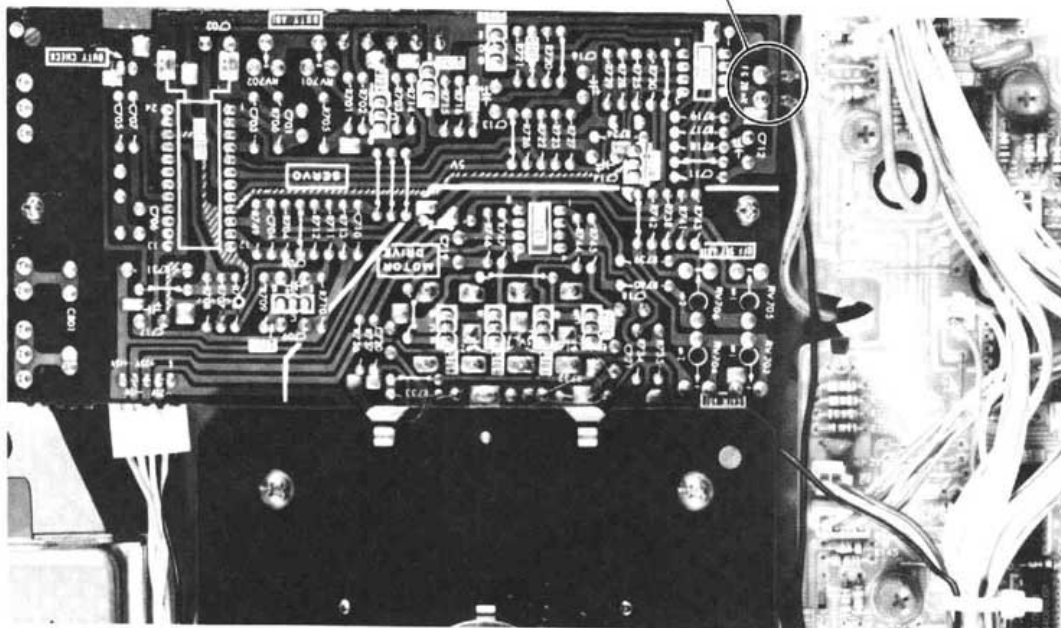

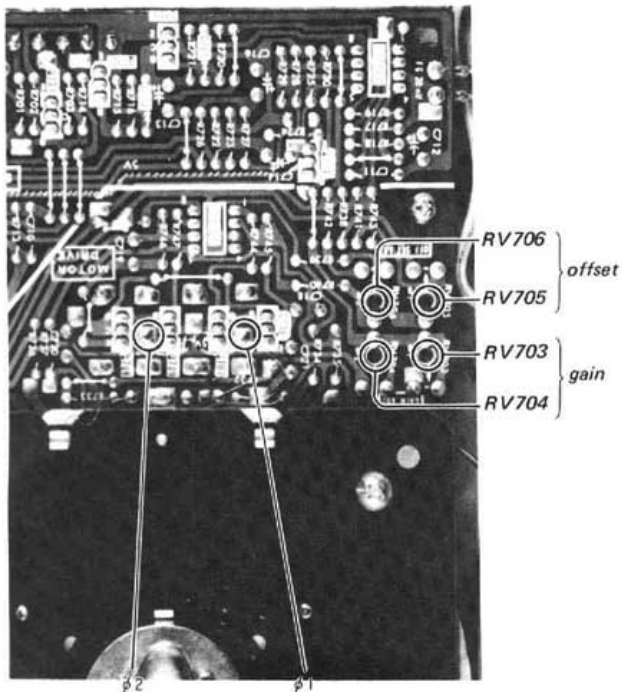

Main Motor Gain/Offset Adjustment

Setting:

Mode: STOP

Supply voltage at IC702 ⑤ so that the voltage at IC702 ⑦ is +2V.

(Gain Adjustment)

1. Turn the POWER switch on.
2. Adjust RV703, 704 so that the voltage at each emitter of Q706 ($\phi 1$) Q709 (ϕ) is 5Vp-p.

(Offset Adjustment)

3. Adjust RV705, 706 so that the waveform at each emitter of Q706 ($\phi 1$) Q709 ($\phi 2$) is as shown below (or reading on the VTVM becomes 0V.)

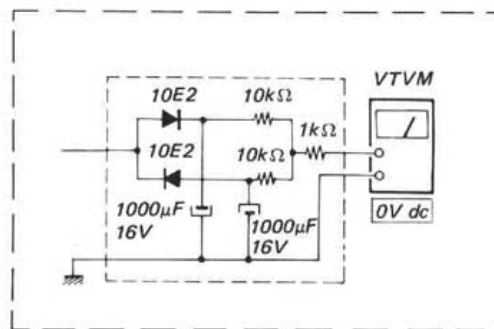

or:

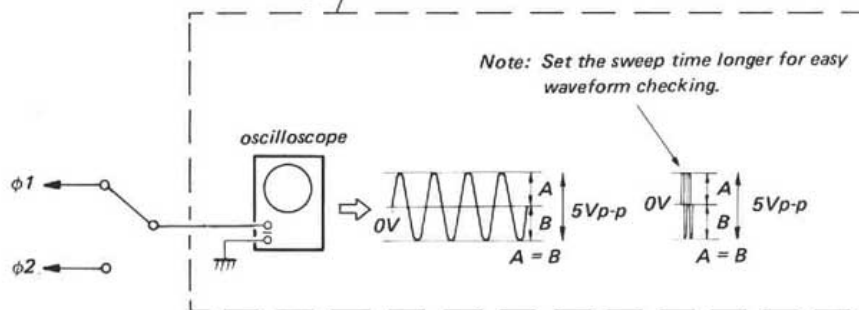

Main Motor Adjustment

Setting:

POWER switch: ON

1. Speed Selector: 33 1/3 rpm
2. Adjust RV702 for specified waveform.
3. SPEED Selector: 45 rpm
4. Adjust RV701 for specified waveform.

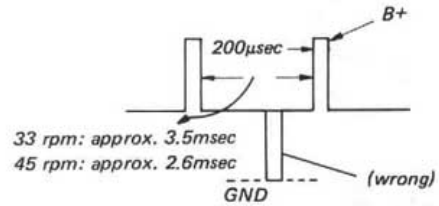

Waveform should appear
at positive side over $\frac{B+}{2}$ level.

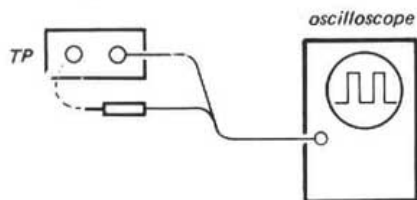
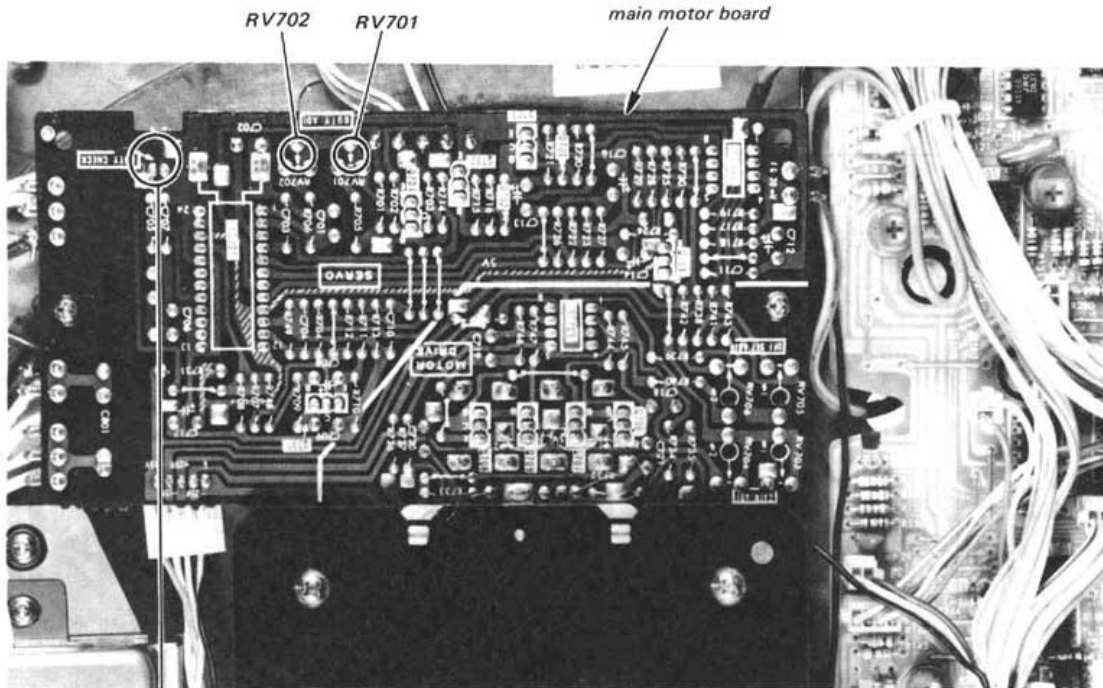

FF Motor Adjustment

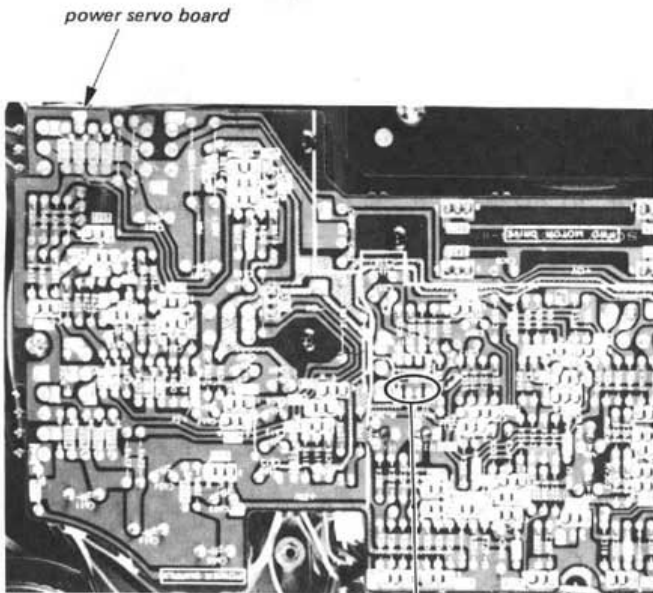

IC302
⑦ ⑤

(Gain Adjustment)

— Connection —

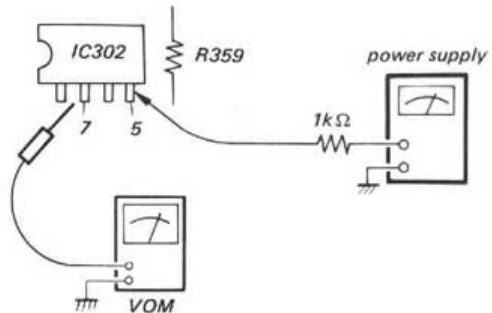

Procedure:

1. Turn POWER switch on.
2. Supply voltage at IC302 ⑤ of the power servo board so that the voltage at terminal ⑦ is +10V.
3. Adjust RV501, 502 so that the output to the motor coil is 24Vp-p.

(Offset Adjustment)

4. Next, adjust RV503, 504 so that the output to the motor coil is as shown below.

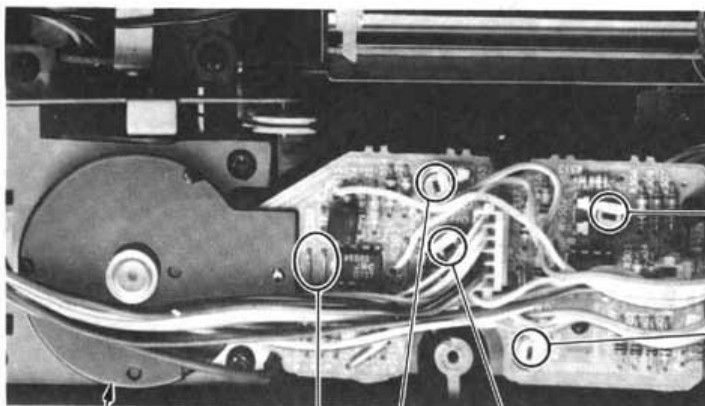

FF motor

RV503 RV504
offset adjustment
output to motor coil

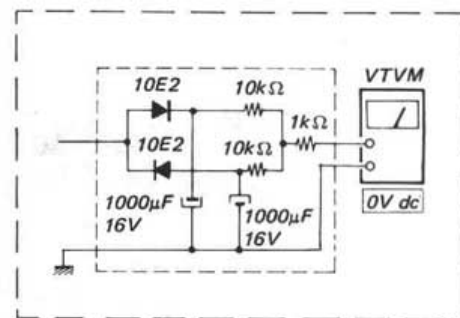

gain adjustment
or:

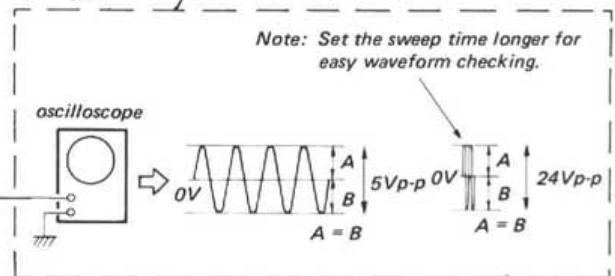

Speed Adjustment

(FAST FF Speed Adjustment)

1. Turn the POWER switch on.
2. To move the tonearm, depress both arm direction button [◀] and FAST button.
3. Adjust RV301 so that the collector output frequency of Q303 is 4,000Hz.

(FF Speed Adjustment)

4. To move the tonearm inward, depress the arm direction button [◀].
5. Adjust RV302 so that the collector output frequency of Q305 is 1000Hz.

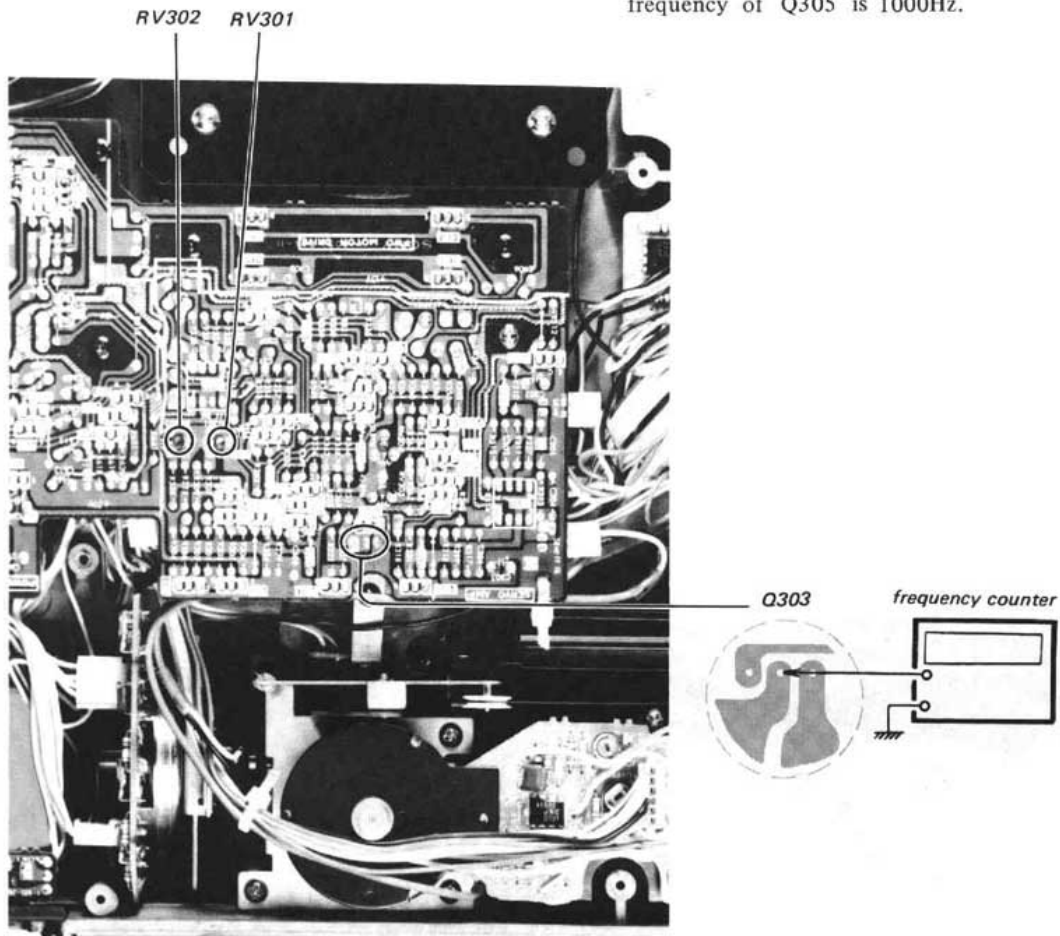

Forward Motor Adjustment

(Gain Adjustment)

— Connection —

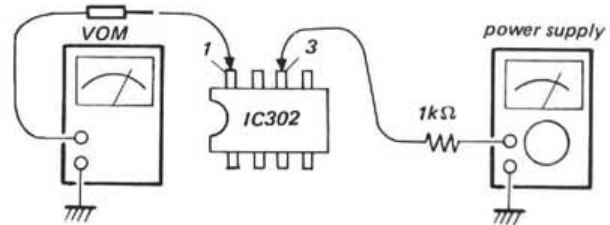

Procedure:

1. Turn the POWER switch on.
2. Supply voltage to IC302 ③ of power servo board so that the voltage at IC302 ① is +10V.
3. Adjust RV401, 402 so that the output to the motor coil is 24Vp-p.

(Offset Adjustment)

4. Adjust RV403, 404 so that output to the motor coil is as shown below.

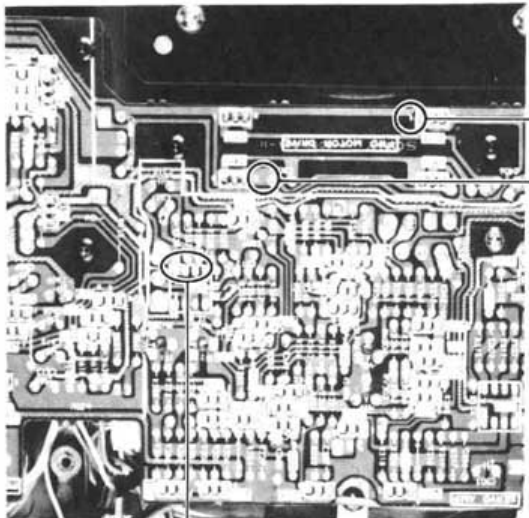

IC302 ① ③

output to motor coil

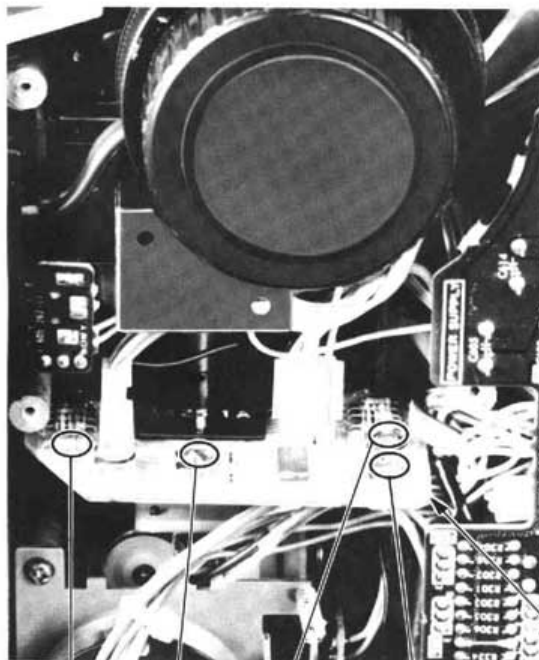

RV401 RV404 RV403 RV402

forward motor board

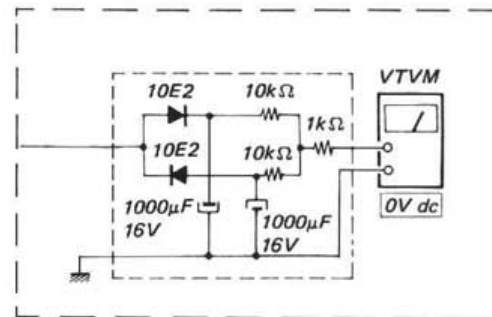

or:

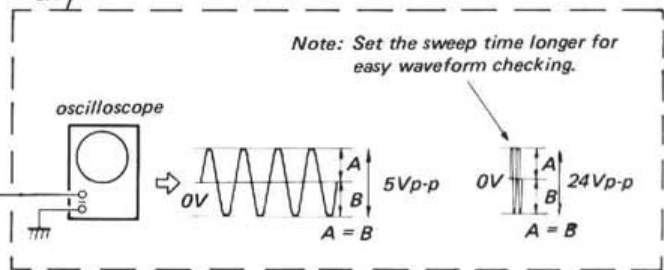

Forward Speed Adjustment

1. Start playing on 33 rpm.
2. Be sure that FG output frequency is 100Hz.
Adjust RV304 promptly to avoid changing the computer program or moving the tonearm by adjustment.

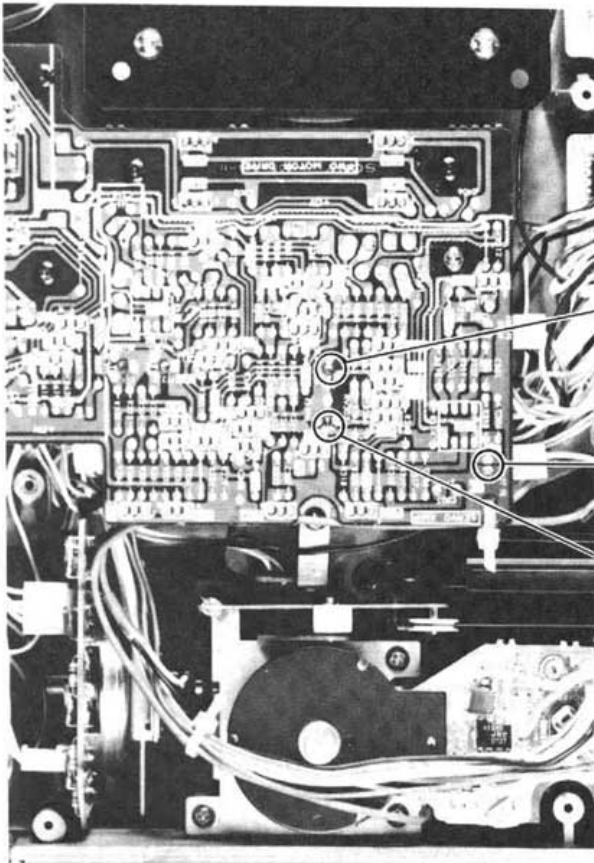

RV304

frequency counter

RV303

3. Start playing on 45 rpm.
4. Be sure that FG output frequency is 150Hz.
Adjust RV303 promptly.

System Control Adjustment

— with the turntable removed —

(The set can be adjusted in upside down position.)

(Rest Area Adjustment)

1. Turn the POWER switch on.
Set the tonearm out of the rest area.
2. Adjust RV106 so that level at TP11 is $-5V$.

(Slit Adjustment)

1. Turn the POWER switch on.
2. Move the tonearm back and forth by hand.
3. Make sure that 50% square wave appears at TP12 (TP13). If necessary, adjust RV104 (RV105).

(HOR Hall Element Offset Adjustment)

1. Turn the POWER switch on.
2. Turn off two switches shown in the figure by turning them counterclockwise. Make sure that output of IC107 is $0 \pm 10mV$ at TP3. If necessary, adjust RV109.
3. Next, make sure that the voltage is $0 \pm 0.1V$ at TP17. If necessary, adjust RV110.

Note: Turn the switch on when the adjustment is completed.

(Balance Circuit Offset Adjustment)

1. Turn the power switch on.
2. Turn off two switches shown in the figure by turning them clockwise.
3. Set the tonearm in the rest area and make sure that level at TP2 is $0 \pm 10mV$. If necessary, adjust RV111.

(Up Adjustment)

1. Turn the POWER switch on.
2. Put the tonearm on the arm rest and push it upwards when the set is at normal position. When the set is positioned upside down, push it downwards.
Make sure that the voltage is $+0.1V$ at TP1. If necessary, adjust RV113.

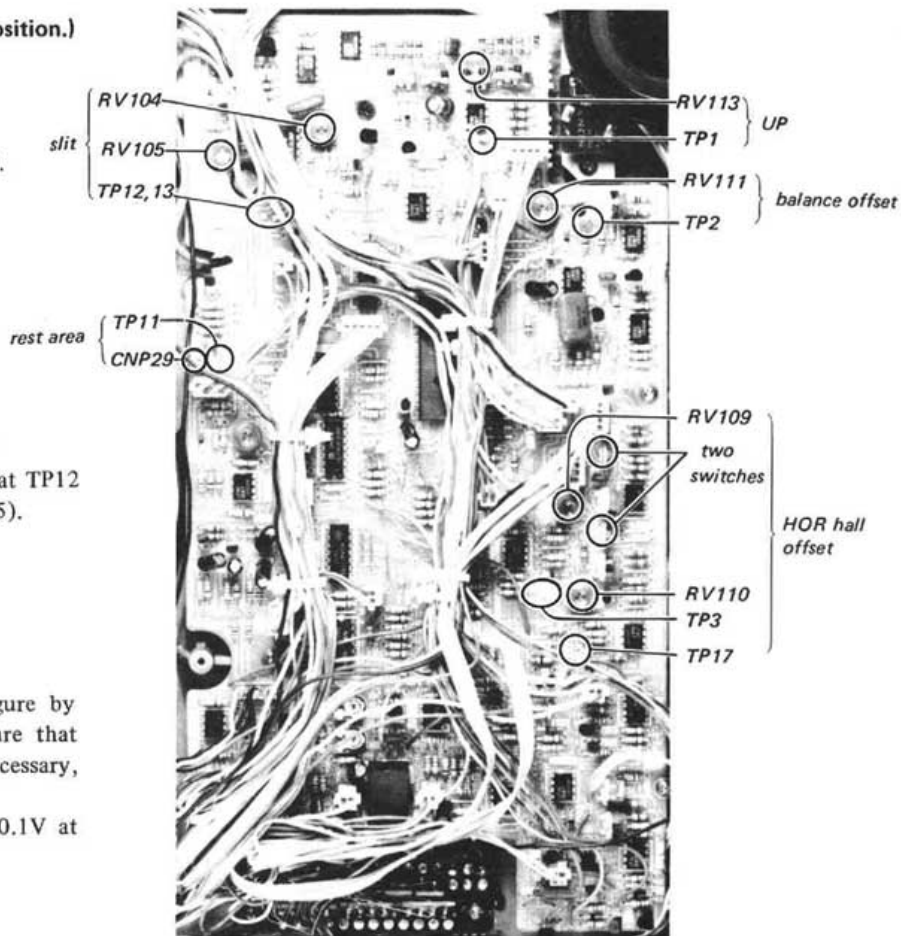

— with the set in normal position —
(either with the turntable removed or not)
(HOR Angle Adjustment)

1. Turn the POWER switch on.
2. Make sure that the tonearm is at a right angle to the slide bar and that voltage at TP17 is 0V. If necessary, adjust RV108 while holding the tonearm by hand.

(HOR Tonearm Detection Adjustment)

3. Next move the stylus tip 0.5mm inward (that is, to the left).
Make sure that voltage at TP17 is -10V.
If necessary, adjust RV107.

(Vertical Angle Adjustment)

cartridge shell weight: 7.2g

1. Place extra weight of 3g on the shell.
2. Turn the POWER switch on.
3. Adjust RV102 so that the tonearm is horizontally balanced.
4. When the tonearm is horizontal, frequency at TP15 is 1600Hz. If necessary, adjust RV103.

(Tonearm Balance Cover Range Adjustment)

Place extra weight of 9g on the shell (7.2g). Make sure that the frequency at TP15 is about 300Hz and that the tonearm drops 1 – 2mm downwards from its horizontal position. If necessary, adjust RV101.

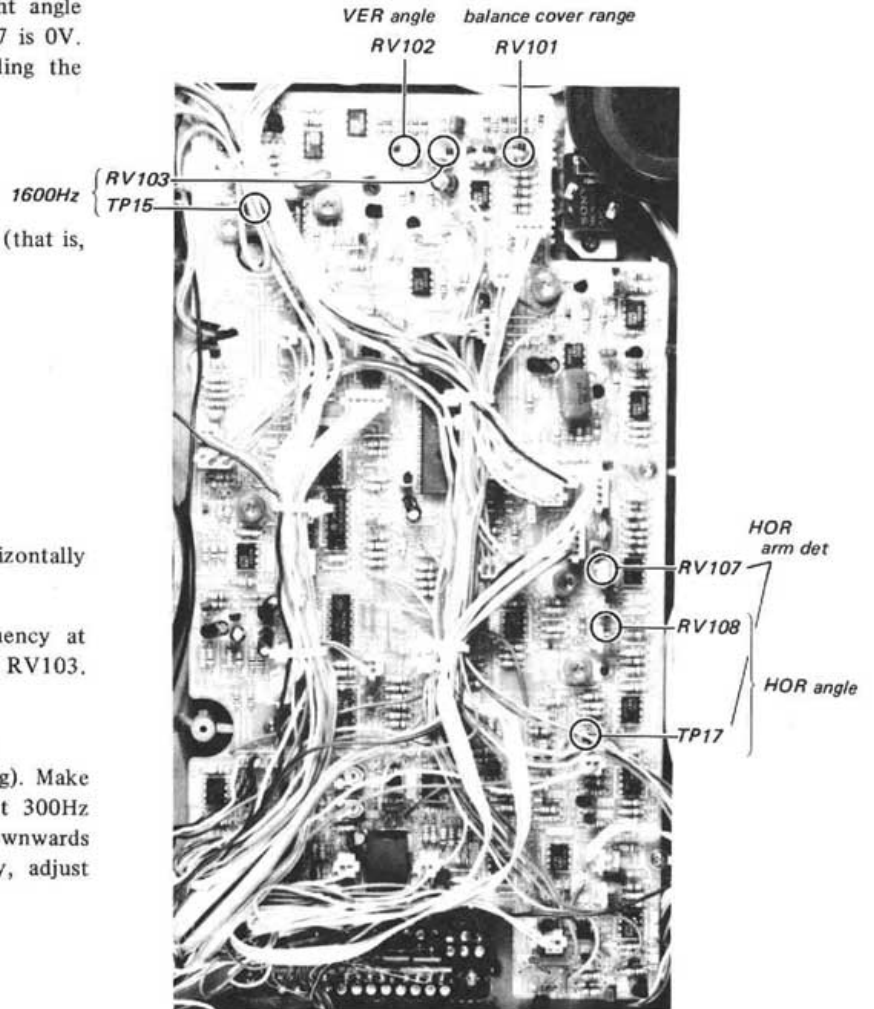

— with the set operating normally —

(Zero Balance Adjustment)

1. Place extra weight of 3g on the shell.
2. During play, check that the voltage at TP8 is about $-0.5V$ and call this voltage "E".
3. When pushing [◀] button, make sure that voltage at TP8 is as identical to "E".
If necessary, adjust RV112.

(Stylus Force Adjustment)







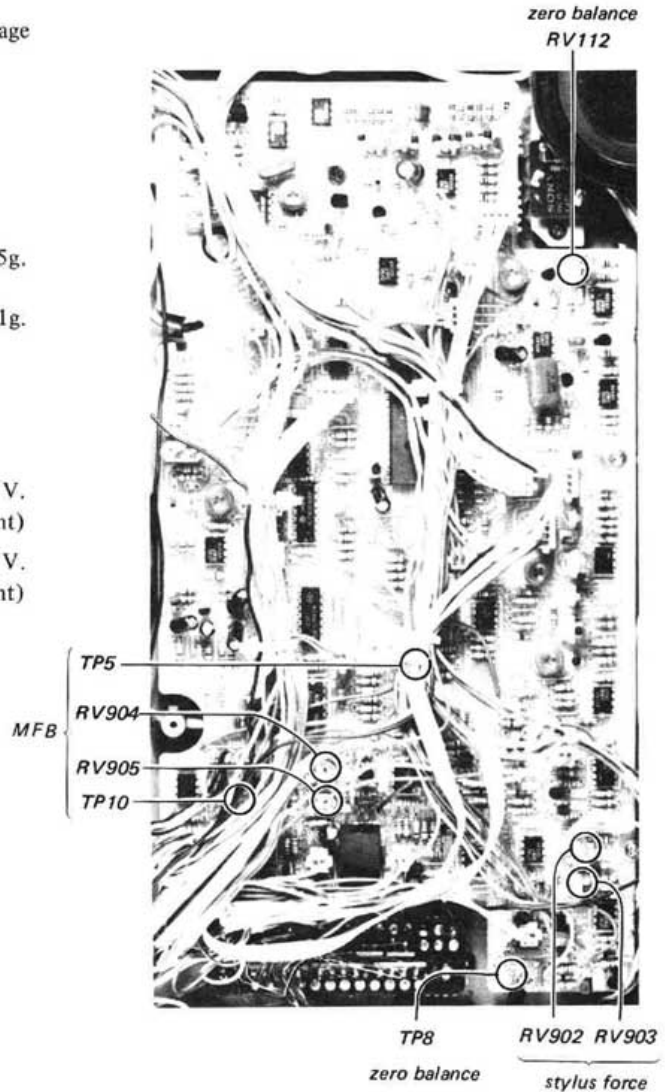



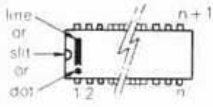

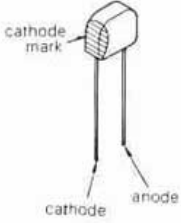
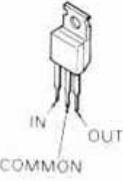
1. Set RV901 (STYLUS) at 2.5g.
2. Adjust RV903 so that the stylus force is 2.5g.
3. Next, set RV901 at 1g.
Adjust RV902 so that the stylus force is 1g.

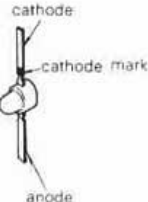
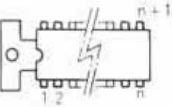
(VER, HOR MFB Adjustment)

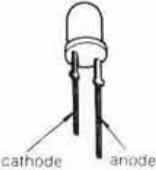
1. Mode: PLAY
2. Adjust RV904 so that voltage at TP5 is $0 \pm 0.1V$.
.....(VER MFB adjustment)
3. Adjust RV905 so that voltage at TP10 is $0 \pm 0.1V$.
..... (HOR MFB adjustment)

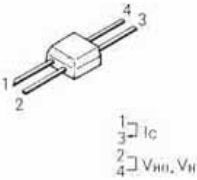

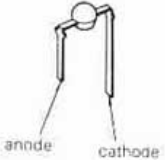
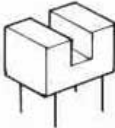
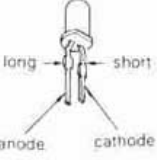
Semiconductor Lead Layouts

<p> μPC741C μPC4557C μPC4558C μPD1511C12 μPD4011C μPD4050C MBB4069B TC4073BP </p>  <p>(Top view)</p>	<p> 2SB834 2SD880 </p> 	<p> HZ7B2L HZ12B3L HZ203L RD2.7E 1S1555 10E 2 </p> 	<p>VD1220</p> 
<p>μPC7805H</p> 	<p>2SC1364</p> 	<p>PH101</p> 	
<p>CX193</p>  <p>(Top view)</p>	<p>2SD774</p> 	<p>SLR54URC</p> 	
<p>MV203V</p> 	<p>2SK30A</p> 	<p>THS102</p> 	
<p>2SA1027R</p> 	<p>AR2222S</p> 	<p> HL300C ON1110 ON1128 </p> 	<p>TLR123</p> 
<p> 2SB731 2SD809 letter side </p> 			

A

B

C

D

5-2.

1

2

3

4

5

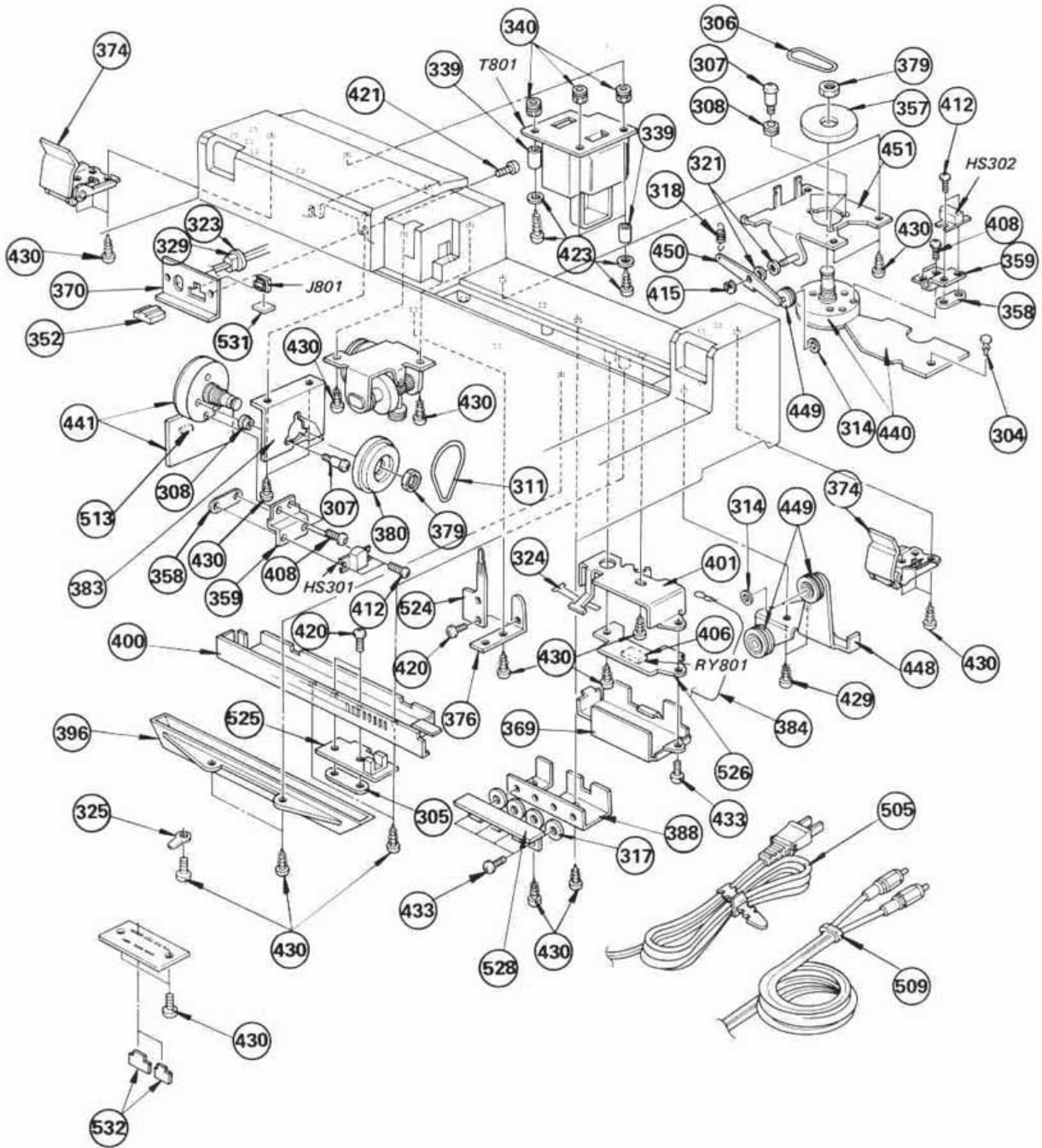

PS-X800

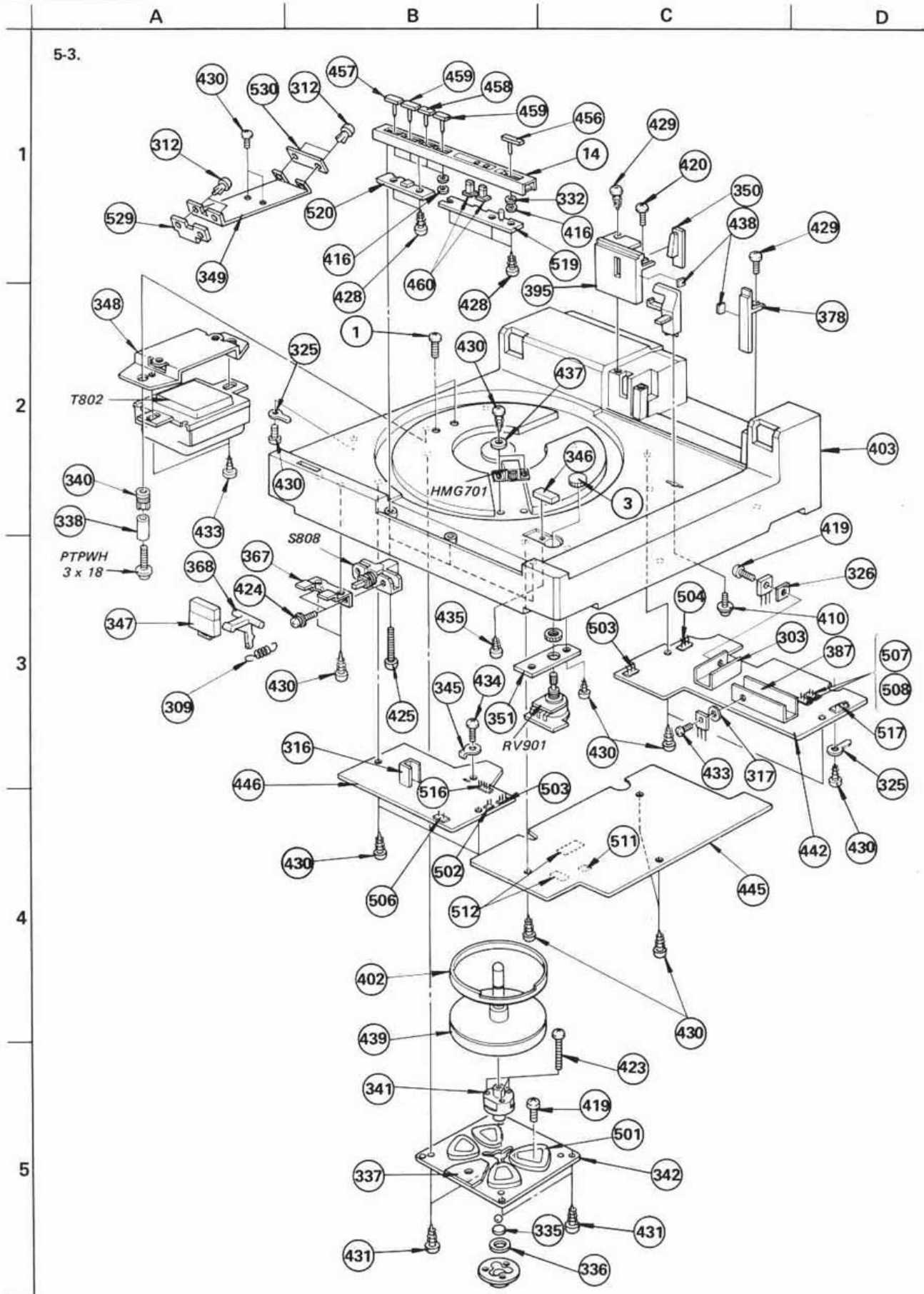

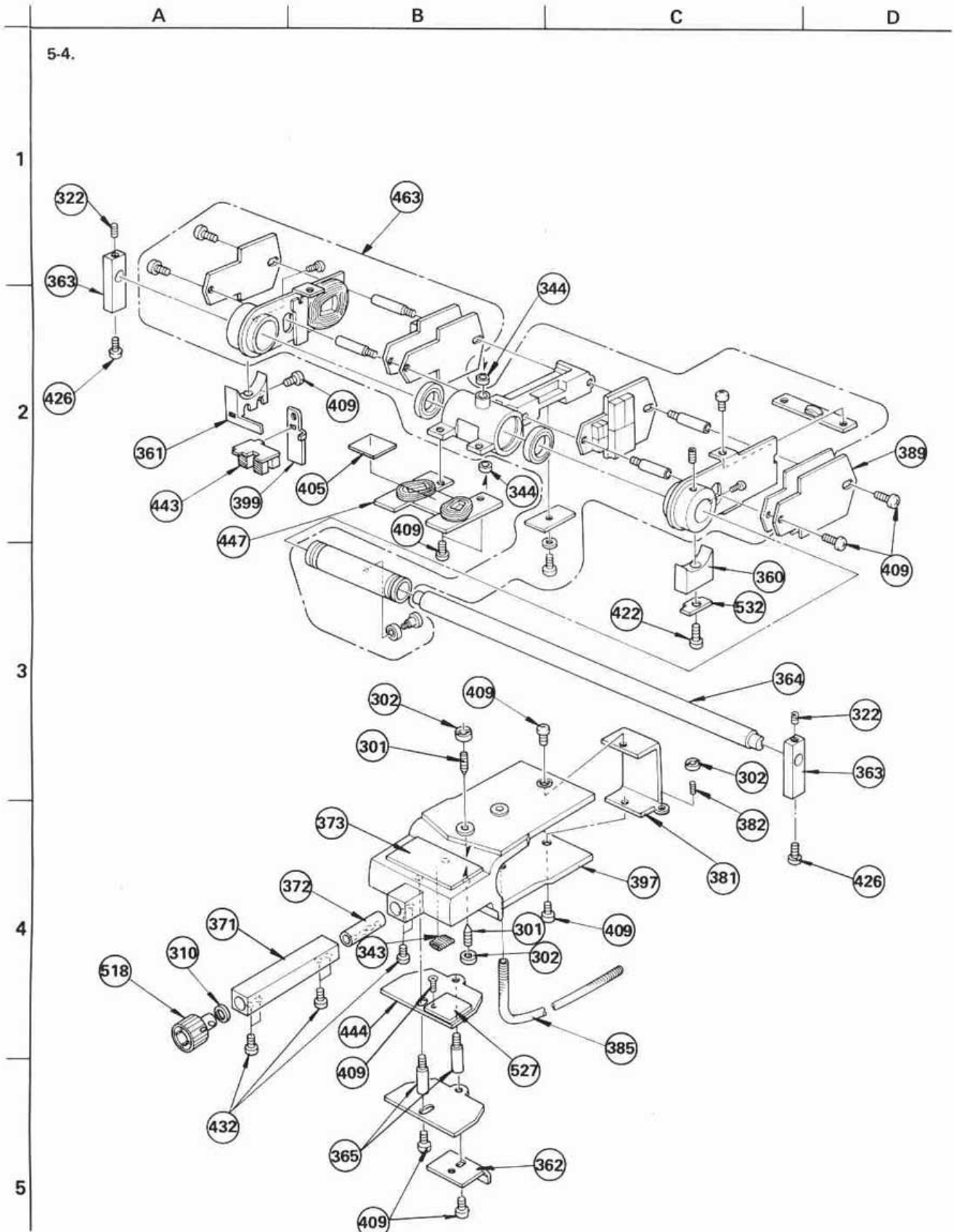

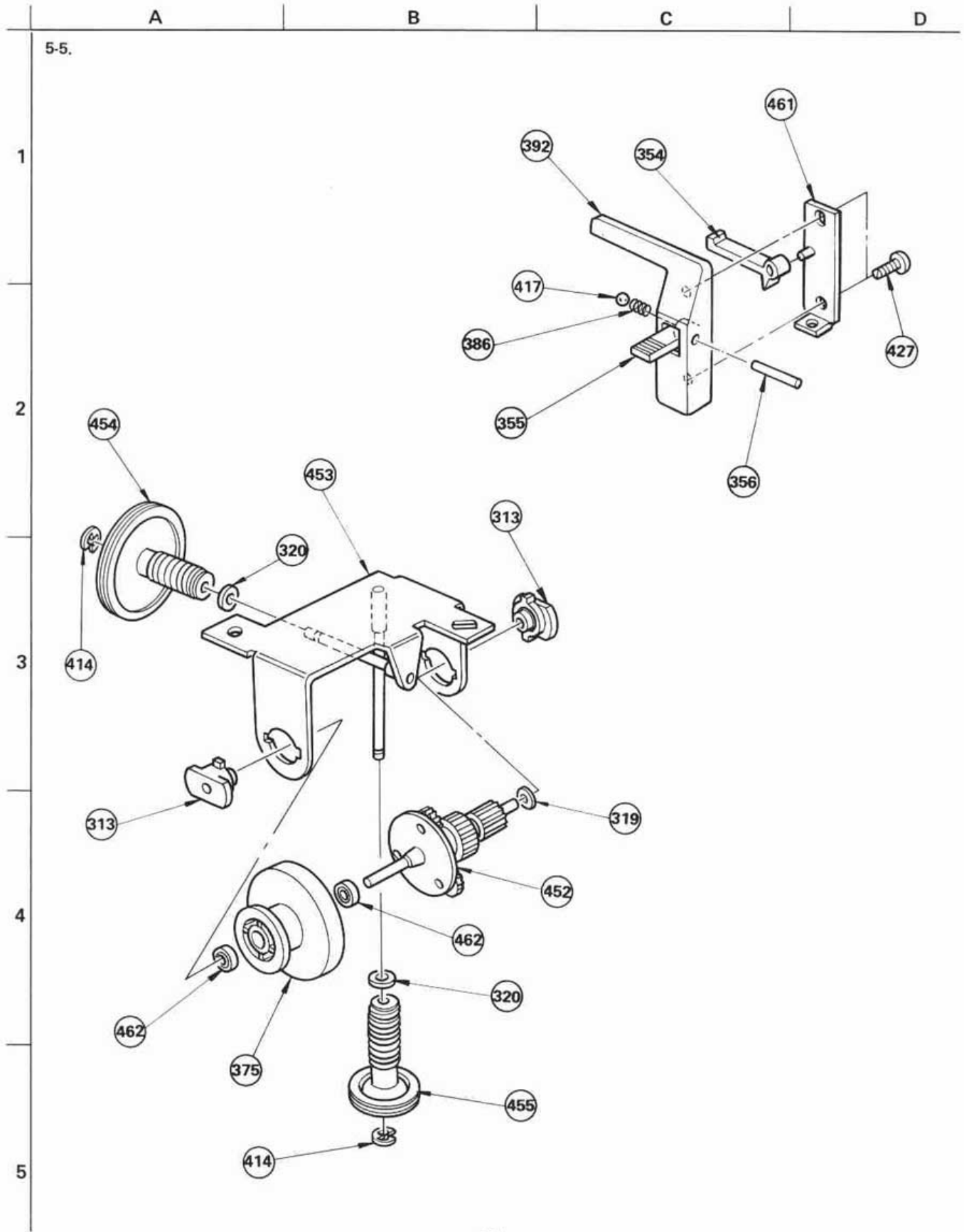

GENERAL SECTION

No.	Part No.	Description
1	4-808-459-11	SCREW (B), MOTOR LOCK
2	4-857-601-00	CUSHION, DUST COVER
3	4-873-307-11	KNOB, STYLUS PRESSURE
4	◆4-878-440-00	PLATE(LOWER), FIXED, TRANSFORMER
5	4-878-473-00	SCREW, LOCK, TRANSFORMER
6	◆4-878-498-01	(AEP,UK).....PLATE, BOTTOM
6	◆4-878-498-11	(Canadian,US)...PLATE, BOTTOM
6	◆4-878-498-21	(E).....PLATE, BOTTOM
7	4-787-507-11	(US).....LALÉL, ARM
8	7-623-925-11	WASHER 4.0, NYLONE
9	7-685-647-21	SCREW +BVTP 3X10 TYPE2 SLIT
10	X-4878-417-0	INSULATOR ASSY
11	X-4878-419-0	COVER ASSY, DUST
12	4-878-521-00	(E).....LABEL, MODEL NUMBER
12	4-878-505-00	(US,Canadian)...LABEL, MODEL NUMBER
12	4-878-522-00	(AEP).....LABEL, MODEL NUMBER
12	4-878-520-00	(UK).....LABEL, MODEL NUMBER
13	4-878-518-11	(US).....LABEL, REPLACEMENT CAUTION
14	X-4878-423-1	PANEL ASSY

ACCESSORY & PACKING MATERIAL

No.	Part No.	Description
	1-551-559-11	LEAD WIRE, WITH TERMINAL (WHT)
	1-551-559-21	LEAD WIRE, WITH TERMINAL (BLU)
	1-551-559-31	LEAD WIRE, WITH TERMINAL (RED)
	1-551-559-41	LEAD WIRE, WITH TERMINAL (GRN)
	2-054-619-00	SPACER, CARTRIDGE
	3-701-613-00	BAG, POLYETHYLENE
	3-701-623-00	BAG, POLYETHYLENE
	3-701-630-00	BAG, POLYETHYLENE
	3-701-634-00	BAG, POLYETHYLENE
	3-783-618-11	(E,AEP,UK).....MANUAL, INSTRUCTION
	3-783-618-21	(US,Canadian).....MANUAL, INSTRUCTION
	4-808-461-00	ADAPTOR, 45RPM
	4-858-589-00	PROTECTOR
	4-870-776-00	PLATE, PROTECTION
34	4-873-301-01	(E,Canadian,AEP,UK)...SHEET, TURNTABLE
34	4-873-301-11	(US).....SHEET, TURNTABLE
35	4-873-302-00	TURNTABLE
36	4-878-455-00	SCREW,COVER,ARM
37	4-878-483-00	SHEET, DAMPING
	4-878-486-01	WEIGHT, SUB
	4-878-486-11	WEIGHT, SUB
40	4-878-492-00	COVER, ARM
	4-878-508-00	INDIVIDUAL CARTON
	4-878-509-00	CUSHION, ARM
	4-878-510-00	CUSHION (SMALL), ARM
	4-878-511-00	BAG, PROTECTION
	4-878-513-00	HOLDER
	4-878-514-00	CUSHION
	4-878-515-00	CUSHION, TT
	4-878-519-00	SHEET, PROTECTION
	X-4878-404-0	SHELL ASSY
	X-4878-421-0	SCREW ASSY, FITTING, CARTRIDGE

NOTE:

- Items with no part number and no description are not stocked because they are seldom required for routine service.
- Items marked "◆" are not stocked since they are seldom required for routine service. Some delay should be anticipated when ordering these items.
- Due to standardization, parts with part numbers (△-△△△-△△△-XX or △-△△△△-△△△-X) may be different from those used in the set.

CAPACITORS:

- All capacitors are in μF. Common capacitors are omitted. Refer to the following lists for their part numbers.
MF:μF, PF:μμF.

RESISTORS

- All resistors are in ohms. Common 1/4W, 1/8W and 1/16W carbon resistors are omitted. Refer to the following lists for their part numbers.

• F : nonflammable

COILS

- MMH : mH, UH : μH

The components identified by shading and mark **▲** are critical for safety. Replace only with part number specified.

Les composants identifiés par une trame et une marque **▲** sont critiques pour la sécurité. Ne les remplacer que par une pièce portant le numéro spécifié.

MECHANISM SECTION

No.	Part No.	Description
301	2-203-518-11	SCREW, PIVOT
302	2-203-519-00	NUT
303	▲;2-239-707-00	HEAT SINK
304	2-249-250-00	CLIP (SMALL), CANOE
305	▲;2-259-215-00	NUT, PLATE (B)
306	3-155-351-00	BELT, COUNTER
307	3-489-077-11	SCREW, MOTOR
308	3-489-112-00	CUSHION, RUBBER
309	3-492-141-XX	SPRING, TENSION (14T)
310	3-493-850-00	WASHER
311	3-513-061-XX	BELT, COUNTER
312	3-531-576-21	RIVET
313	▲;3-551-904-00	SHAFT
314	3-558-708-11	WASHER, STOPPER
315	
316	▲;3-567-242-00	HEAT SINK
317	3-572-365-01	SHEET (A), INSULATING
318	3-645-135-00	SPRING, TENSION
319	3-701-437-21	WASHER
320	3-701-438-21	WASHER
321	3-701-439-21	WASHER
322	3-701-505-00	SET SCREW, DOUBLE POINT 3X3
323	3-701-682-00	(E,US,Canadian)....STOPPER, CORD
324	3-701-748-00	CLAMP
325	3-701-822-00	HOLDER, WIRE
326	3-703-037-00	INSULATOR, T0-220
327	3-703-043-21	(US,Canadian,UK)...LABEL, CAUTION, MAIN
328	3-703-082-21	(US).....LABEL, CAUTION
329	3-703-244-02	(US,AEP)...BUSHING, CORD
330	
331	3-795-254-11	(US).....LABEL, CAUTION, TRANSPORT SCREW
332	3-831-441-XX	CUSHION, VIBRATION PREVENTION
333	4-314-529-00	HEAD, WASHER, TAPPING SCREW
334	4-836-828-00	EMBLEM, SONY
335	4-852-007-00	RETAINER (A), THRUST
336	4-855-627-00	RING, O
337	4-857-642-00	HOLDER, PC BOARD
338	4-858-513-00	SPACER
339	4-858-518-00	SLEEVE
340	4-858-522-00	RUBBER, FLOATING
341	4-858-616-00	BEARING, MOTOR
342	▲;4-858-648-00	FRAME, MOTOR
343	▲;4-862-555-00	YOKE, SHIELD
344	4-863-604-00	BEARING, PIVOT
345	4-870-539-00	PLATE, GROUND

NOTE:

- * Items with no part number and no description are not stocked because they are seldom required for routine service.
- * Items marked "▲" are not stocked since they are seldom required for routine service. Some delay should be anticipated when ordering these items.
- * Due to standardization, parts with part numbers (▲-▲▲▲-▲▲▲-XX or ▲-▲▲▲-▲▲▲-X) may be different from those used in the set.

MECHANISM SECTION

No.	Part No.	Description
346	4-873-309-11	ESCUTCHEON, KNOB
347	4-873-313-00	KNOB, POWER
348	▲;4-873-317-00	HOLDER, TRANSFORMER
349	▲;4-873-318-00	HOLDER (A), SIZE
350	4-873-320-00	LENS
351	▲;4-873-327-00	BRACKET, CONTROL
352	4-873-331-00	HOLDER, JACK
353	
354	4-878-401-00	ARM, REST
355	4-878-402-00	LEVER, REST
356	4-878-404-00	SHAFT, LEVER, REST
357	▲;4-878-406-00	RING (1), FG
358	▲;4-878-410-00	NUT, PLATE
359	▲;4-878-411-00	BRACKET, HEAD
360	4-878-415-00	HOLDER (R), PC BOARD, ARM
361	4-878-416-00	HOLDER (L), PC BOARD, ARM
362	▲;4-878-417-00	CLAMP, LEAD, ARM
363	▲;4-878-420-00	SUPPORT, SHAFT
364	4-878-421-00	SHAFT, ARM
365	▲;4-878-423-00	SUPPORT, YOKE, HORIZONTAL
366	4-878-425-00	NUT, RETAINER, PANEL
367	▲;4-878-430-00	BASE, SWITCH, POWER
368	▲;4-878-431-00	LEVER, SWITCH, POWER
369	▲;4-878-437-00	PLATE (LOWER), SHIELD
370	▲;4-878-438-00	(E,US,Canadian)...BRACKET, CORD, POWER
370	4-878-472-00	(AEP,UK).....BRACKET, CORD, POWER
371	4-878-439-00	PIPE
372	▲;4-878-441-00	NUT, PIPE
373	4-878-442-00	PLATE, ORNAMENTAL, ARM
374	4-878-443-00	HINGE
375	▲;4-878-453-00	GEAR, U
376	▲;4-878-454-00	HOLDER, LAMP
377	4-878-456-00	SCREW, RETAINER, COVER
378	4-878-457-00	COVER (R), SUPPORT, ARM
379	▲;4-878-458-00	NUT, FG
380	▲;4-878-459-00	RING (2), FG
381	▲;4-878-462-00	REINFORCEMENT
382	4-878-463-00	SCREW, ADJUSTMENT, HEIGHT
383	▲;4-878-465-00	BRACKET, MOTOR, FW
384	4-878-478-00	WIRE
385	4-878-479-00	SPRING
386	4-878-480-00	SPRING, COMPRESSION
387	▲;4-878-481-00	HEAT SINK (1)
388	▲;4-878-482-00	HEAT SINK (2)
389	▲;4-878-484-01	WEIGHT, ADJUSTMENT
389	▲;4-878-484-11	WEIGHT, ADJUSTMENT
389	▲;4-878-484-21	WEIGHT, ADJUSTMENT

CAPACITORS:

- * All capacitors are in μF . Common capacitors are omitted. Refer to the following lists for their part numbers.
- MF: μF , PF: μF .

RESISTORS

- * All resistors are in ohms. Common 1/4W, 1/8W and 1/16W carbon resistors are omitted. Refer to the following lists for their part numbers.
- * F : nonflammable

COILS

- * MMH : mH, UH : μH

The components identified by shading and mark ▲ are critical for safety. Replace only with part number specified.

Les composants identifiés par une trame et une marque ▲ sont critiques pour la sécurité. Ne les remplacer que par une pièce portant le numéro spécifié.

MECHANISM SECTION

No.	Part No.	Description
392	4-878-487-00	BASE, REST
393	4-878-489-00	BASE (L), INSULATOR
394	4-878-490-00	BASE (F), INSULATOR
395	4-878-493-00	COVER (L), SUPPORT, ARM
396	4-878-494-00	GUIDE, LEAD, ARM
397	4-878-495-00	BASE, ARM
399	▲;4-878-499-00	PLATE, SHUTTER
400	▲;4-878-501-00	PLATE, SLIT
401	▲;4-878-502-00	PLATE (UPPER), SHIELD
402	▲;4-878-503-00	PLATE, SHIELD, MOTOR
403	▲;4-878-504-00	FRAME
404	4-878-507-01	(UK,AEP).....SHEET, INSTRUCTION
404	4-878-507-11	(Canadian,US)...SHEET, INSTRUCTION
405	4-878-516-00	RETAINER, HOLE ELEMENT
406	4-878-517-00	COVER, RELAY SWITCH
407	
408	7-621-259-15	SCREW +P 2.6X3
409	7-621-259-39	SCREW +P 2.6X5
410	7-621-759-85	+PSW, 2.6X12
411	7-621-772-00	SCREW +B 2X3
412	7-621-772-10	SCREW +B 2X4
413	
414	7-624-102-04	STOP RING 1.5, TYPE -E
415	7-624-104-04	STOP RING 2.0, TYPE -E
416	7-624-190-81	STOP RING 2, TYPE-CS
417	7-671-112-01	STEEL, BALL
418	7-682-145-01	SCREW +P 3X4
419	7-682-147-20	SCREW +P 3X6
420	7-682-546-09	SCREW +B 3X5
421	7-682-548-09	SCREW +B 3X8
422	7-682-550-09	SCREW +B 3X12
423	7-682-552-09	SCREW +B 3X16
424	7-682-646-01	SCREW +PS 3X5
425	7-682-954-01	SCREW +PSW 3X25
426	7-682-963-09	SCREW +PSW 4X14
427	7-685-131-29	SCREW +P 2.6X4 TYPE2 SLIT
428	7-685-534-29	SCREW +BTP 2.6X8 TYPE2 N-S
429	7-685-646-29	SCREW +BVTP 3X8 TYPE2 SLIT
430	7-685-647-21	SCREW +BVTP 3X10 TYPE2 SLIT
431	7-685-661-71	SCREW +BVTP 4X12 TYPE2 SLIT
432	7-685-799-74	SCREW,+PTT 1.7X3
433	7-685-871-01	SCREW +BVTT 3X6 (S)
434	7-685-872-01	SCREW +BVTT 3X8 (S)
435	7-687-233-21	SCREW,TOTSU PTPWH 2.6X6,TYPE2

MECHANISM SECTION

No.	Part No.	Description
436	7-688-002-12	W 2.6, MIDDLE
437	7-688-003-12	W 3, MIDDLE
438	9-911-839-XX	CUSHION
439	X-4878-425-1	ROTOR ASSY
440	A-4608-189-A	MOTOR ASSY, FF
441	A-4608-191-A	MOTOR ASSY, FW
443	1-605-250-00	PC BOARD, SLIT
444	A-4638-044-A	YOKE ASSY, HORIZONTAL
447	A-4647-049-A	PC BOARD ASSY, MFB, HORIZONTAL
448	▲;X-4878-401-0	BRACKET ASSY, PULLEY, MIDWAY
449	X-4878-405-1	PULLEY ASSY
450	▲;X-4878-407-0	LEVER ASSY, TENSION
451	▲;X-4878-408-0	BRACKET ASSY, MOTOR, FF
452	X-4878-409-0	WORM ASSY
453	▲;X-4878-410-0	SUPPORT ASSY, BLOCK, GEAR
454	▲;X-4878-411-0	PULLEY ASSY, FW
455	▲;X-4878-412-0	PULLEY ASSY, FF
456	X-4878-413-0	PUSHBUTTON ASSY
457	X-4878-414-1	PUSHBUTTON ASSY
458	X-4878-414-2	PUSHBUTTON ASSY
459	X-4878-414-3	PUSHBUTTON ASSY
460	X-4878-415-0	PUSHBUTTON ASSY
461	▲;X-4878-416-0	PLATE ASSY, REAR, REST
462	4-878-475-00	BEARING, RADIAL
463	X-4878-424-1	BEARING HOLDER ASSY
464	▲;4-878-524-00	HOLDER, FUSE

NOTE:

- Items with no part number and no description are not stocked because they are seldom required for routine service.
- Items marked "▲" are not stocked since they are seldom required for routine service. Some delay should be anticipated when ordering these items.
- Due to standardization, parts with part numbers (Δ-ΔΔΔ-ΔΔΔ-XX or Δ-ΔΔΔΔ-ΔΔΔ-X) may be different from those used in the set.

CAPACITORS:

- All capacitors are in μF. Common capacitors are omitted. Refer to the following lists for their part numbers.
MF:μF, PF:μμF.

RESISTORS

- All resistors are in ohms. Common 1/4W, 1/8W and 1/16W carbon resistors are omitted. Refer to the following lists for their part numbers.

• F : nonflammable

COILS

- MMH : mH, UH : μH

The components identified by shading and mark ▲ are critical for safety. Replace only with part number specified.

Les composants identifiés par une trame et une marque ▲ sont critiques pour la sécurité. Ne les remplacer que par une pièce portant le numéro spécifié.

ELECTRICAL PARTS

Ref.No.	Part No.	Description
501	1-462-161-21	COIL, MOTOR
502	▲;1-508-799-00	BASE POST (U TYPE)
503	▲;1-508-800-13	U TYPE BASE POST 3P
504	▲;1-508-801-00	U TYPE BASE POST 4P
505	▲;1-534-817-31	(AEP).....CORD, POWER
505	▲;1-551-473-31	(E).....CORD, POWER
505	▲;1-551-508-21	(US,Canadian)...CORD, POWER
505	▲;1-551-884-41	(UK).....CORD, POWER
507	▲;1-535-116-31	TERMINAL (3PL)
507	▲;1-535-116-21	TERMINAL (3PS)
508	▲;1-535-117-00	TERMINAL
509	1-551-546-00	CORD (WITH PLUG)
511	▲;1-560-060-00	PIN, CONNECTOR 2P
512	▲;1-560-061-00	PIN, CONNECTOR 3P
513	▲;1-560-062-00	PIN, CONNECTOR 4P
514	▲;1-560-063-00	PIN, CONNECTOR 5P
515	▲;1-560-064-00	PIN, CONNECTOR 6P
516	▲;1-560-070-00	BASE POST
517	▲;1-560-200-00	BASE POST, MCD CONNECTOR 2P
518	1-561-201-31	CONNECTOR, NECK CYLINDER
519	▲;1-605-243-00	PC BOARD, SW (A)
520	▲;1-605-244-00	PC BOARD, SW (B)
521	▲;A-4618-068-A	MOUNTED PCB, POWER
522	▲;A-4646-068-A	MOUNTED PCB, SYSTEM CONTROL
523	▲;A-4646-069-A	(US).....MOUNTED PCB, MOTOR
523	▲;A-4646-070-A	(Canadian).....MOUNTED PCB, MOTOR
523	▲;A-4646-071-A	(E,UK,AEP).....MOUNTED PCB, MOTOR
524	▲;1-605-248-00	PC BOARD, LAMP
525	▲;1-605-249-00	PC BOARD, REST AREA
526	▲;1-605-251-00	PC BOARD, PHONO
527	▲;1-605-255-00	PC BOARD, LED
528	▲;1-605-256-00	PC BOARD, FF TRANSISTOR
529	▲;1-605-259-00	PC BOARD, SIZE (A)
530	▲;1-605-260-00	PC BOARD, SIZE (B)
531	▲;1-605-262-00	PC BOARD, REMOTE CONTROL
532	▲;1-606-170-00	(AEP,UK)...PC BOARD, FUZE
533	1-533-131-10	(AEP,UK)...HOLDER, FUZE
C601	▲;1-123-364-51	ELECT 1000MF 50V
C602	▲;1-123-364-51	ELECT 1000MF 50V
C603	▲;1-123-334-51	ELECT 220MF 25V
C605	▲;1-123-349-51	ELECT 1000MF 35V
C607	▲;1-123-298-51	ELECT 470MF 6.3V
C611	▲;1-123-350-51	ELECT 2200MF 35V
C614	▲;1-123-350-51	ELECT 2200MF 35V
C612	▲;1-123-321-51	ELECT 220MF 16V
C717	▲;1-123-299-00	ELECT 1000MF 6.3V
C801	▲;1-161-744-00	(E,AEP,UK)..CERAMIC 0.01MF 400V
C801	▲;1-130-098-21	(Canadian)..POLYPROPYLENE 0.022MF 125V
C801	▲;1-130-233-61	(US).....METALLIZED FILM 0.033MF 125V

NOTE:

- Items with no part number and no description are not stocked because they are seldom required for routine service.
- Items marked "▲" are not stocked since they are seldom required for routine service. Some delay should be anticipated when ordering these items.
- Due to standardization, parts with part numbers (Δ-ΔΔΔ-ΔΔΔ-XX or Δ-ΔΔΔΔ-ΔΔΔ-X) may be different from those used in the set.

CAPACITORS:

- All capacitors are in μF. Common capacitors are omitted. Refer to the following lists for their part numbers. MF:μF, PF:μF.

RESISTORS

- All resistors are in ohms. Common 1/4W, 1/8W and 1/16W carbon resistors are omitted. Refer to the following lists for their part numbers.

- F : nonflammable

COILS

- MMH : mH, UH : μH

ELECTRICAL PARTS

Ref.No.	Part No.	Description
D101	8-719-991-43	DIODE HZ4A3
D102	8-719-815-55	DIODE 1S1555
D103	8-719-815-55	DIODE 1S1555
D104	8-719-990-65	DIODE HZ6B2L
D105	8-719-815-55	DIODE 1S1555
D106	8-719-815-55	DIODE 1S1555
D107	8-719-815-55	DIODE 1S1555
D108	8-719-815-55	DIODE 1S1555
D109	8-719-815-55	DIODE 1S1555
D110	8-719-815-55	DIODE 1S1555
D111	8-719-991-43	DIODE HZ4A3
D112	8-719-122-00	DIODE VD1220
D113	8-719-815-55	DIODE 1S1555
D114	8-719-815-55	DIODE 1S1555
D115	8-719-815-55	DIODE 1S1555
D116	8-719-815-55	DIODE 1S1555
D117	8-719-815-55	DIODE 1S1555
D118	8-719-815-55	DIODE 1S1555
D119	8-719-815-55	DIODE 1S1555
D120	8-719-815-55	DIODE 1S1555
D121	8-719-815-55	DIODE 1S1555
D122	8-719-815-55	DIODE 1S1555
D123	8-719-815-55	DIODE 1S1555
D124	8-719-815-55	DIODE 1S1555
D125	8-719-815-55	DIODE 1S1555
D126	8-719-815-55	DIODE 1S1555
D127	8-719-815-55	DIODE 1S1555
D128	8-719-815-55	DIODE 1S1555
D129	8-719-815-55	DIODE 1S1555
D131	8-719-200-02	DIODE 10E-2
D132	8-719-920-30	DIODE MV-203V
D133	8-719-920-30	DIODE MV-203V
D134	8-719-920-30	DIODE MV-203V
D201	8-719-815-55	DIODE 1S1555
D202	8-719-815-55	DIODE 1S1555
D301	8-719-815-55	DIODE 1S1555
D302	8-719-815-55	DIODE 1S1555
D303	8-719-815-55	DIODE 1S1555
D304	8-719-815-55	DIODE 1S1555
D305	8-719-127-07	DIODE RD2.7E-8
D307	8-719-815-55	DIODE 1S1555
D601	▲;8-719-200-02	DIODE 10E-2
D602	▲;8-719-200-02	DIODE 10E-2
D603	▲;8-719-200-02	DIODE 10E-2
D604	▲;8-719-200-02	DIODE 10E-2
D605	▲;8-719-200-02	DIODE 10E-2
D606	8-719-990-03	DIODE HZ20-3L
D607	8-719-815-55	DIODE 1S1555
D608	▲;8-719-200-02	DIODE 10E-2
D609	▲;8-719-200-02	DIODE 10E-2

The components identified by shading and mark ▲ are critical for safety. Replace only with part number specified.

Les composants identifiés par une trame et une marque ▲ sont critiques pour la sécurité. Ne les remplacer que par une pièce portant le numéro spécifié.

ELECTRICAL PARTS

Ref.No.	Part No.	Description
D610	▲ 8-719-200-02	DIODE 10E-2
D611	▲ 8-719-200-02	DIODE 10E-2
D612	8-719-990-75	DIODE HZ782L
D613	8-719-990-75	DIODE HZ782L
D614	8-719-815-55	DIODE 1S1555
D615	8-719-815-55	DIODE 1S1555
D616	8-719-815-55	DIODE 1S1555
D617	8-719-815-55	DIODE 1S1555
D618	8-719-910-26	DIODE HZ12B3L
D701	8-719-815-55	DIODE 1S1555
D702	8-719-815-55	DIODE 1S1555
D801	8-719-905-40	DIODE SLR-54URC
D802	8-719-905-40	DIODE SLR-54URC
D803	8-719-905-40	DIODE SLR-54URC
D804	8-719-905-40	DIODE SLR-54URC
D805	8-719-812-31	DIODE TLR123
D806	8-719-922-21	DIODE AR2222S
D807	8-719-200-02	DIODE 10E-2
H401	8-719-814-11	DIODE THS102
H402	8-719-814-11	DIODE THS102
H501	8-719-814-11	DIODE THS102
H502	8-719-814-11	DIODE THS102
H701	8-719-903-00	HALL ELEMENT HL-300C
H702	8-719-903-00	HALL ELEMENT HL-300C
H801	8-719-814-11	DIODE THS102
H802	8-719-814-11	DIODE THS102
HS301	1-543-093-00	HEAD
HS302	1-543-093-00	HEAD
HMG701	1-543-123-00	HEAD
IC101	8-759-145-58	IC UPC4558C
IC102	8-759-145-58	IC UPC4558C
IC103	8-759-145-58	IC UPC4558C
IC104	8-759-145-57	IC UPC4557C
IC106	8-759-145-58	IC UPC4558C
IC107	8-759-174-11	IC UPC741C
IC108	8-759-145-58	IC UPC4558C
IC109	8-759-145-58	IC UPC4558C
IC110	8-759-145-58	IC UPC4558C
IC111	8-759-110-12	IC UPD1511C12
IC112	8-759-145-58	IC UPC4558C
IC113	8-759-145-58	IC UPC4558C
IC114	8-759-145-58	IC UPC4558C
IC115	8-759-145-58	IC UPC4558C
IC116	8-759-145-58	IC UPC4558C
IC117	8-759-145-58	IC UPC4558C
IC118	8-759-145-58	IC UPC4558C
IC119	8-759-145-58	IC UPC4558C
IC120	8-759-145-58	IC UPC4558C
IC121	8-759-145-58	IC UPC4558C

ELECTRICAL PARTS

Ref.No.	Part No.	Description
IC122	8-759-145-58	IC UPC4558C
IC151	8-759-904-69	IC MSM4069
IC152	8-759-904-69	IC MSM4069
IC153	8-759-904-69	IC MSM4069
IC154	8-759-940-50	IC MSM4050
IC155	8-759-940-11	IC MSM4011
IC156	8-759-940-11	IC MSM4011
IC157	8-759-940-73	IC MSM4073
IC201	8-751-930-00	IC CX-193
IC202	8-759-145-57	IC UPC4557C
IC203	8-759-145-58	IC UPC4558C
IC301	8-759-145-58	IC UPC4558C
IC302	8-759-145-57	IC UPC4557C
IC401	8-759-145-58	IC UPC4558C
IC501	8-759-145-58	IC UPC4558C
IC502	8-759-145-58	IC UPC4558C
IC601	8-759-171-05	IC UPC7805H
IC701	8-751-930-00	IC CX-193
IC702	8-759-145-58	IC UPC4558C
IC703	8-759-145-58	IC UPC4558C
J801	1-507-688-21	JACK (STEREO PLUG)
L101	1-407-157-XX	MICRO INDUCTOR 10UH
L102	1-407-157-XX	MICRO INDUCTOR 10UH
PC801	8-719-411-28	DIODE ON1128
PC802	8-719-411-10	DIODE ON1110
PC803	8-719-411-10	DIODE ON1110
PL801	1-518-470-00	LAMP, PILOT
PL802	1-518-421-00	LAMP, PILOT
Q101	8-729-612-77	TRANSISTOR 2SA1027R
Q102	8-729-203-02	TRANSISTOR 2SK30A
Q103	8-729-203-02	TRANSISTOR 2SK30A
Q104	8-729-663-47	TRANSISTOR 2SC1364
Q105	8-729-663-47	TRANSISTOR 2SC1364
Q106	8-729-612-77	TRANSISTOR 2SA1027R
Q107	8-729-612-77	TRANSISTOR 2SA1027R
Q108	8-729-612-77	TRANSISTOR 2SA1027R
Q109	8-729-663-47	TRANSISTOR 2SC1364
Q110	8-729-663-47	TRANSISTOR 2SC1364
Q111	8-729-663-47	TRANSISTOR 2SC1364
Q112	8-729-663-47	TRANSISTOR 2SC1364
Q113	8-729-612-77	TRANSISTOR 2SA1027R
Q114	8-729-177-43	TRANSISTOR 2SD774
Q115	8-729-663-47	TRANSISTOR 2SC1364
Q116	8-729-203-02	TRANSISTOR 2SK30A
Q117	8-729-203-02	TRANSISTOR 2SK30A
Q118	8-729-203-02	TRANSISTOR 2SK30A
Q119	8-729-203-02	TRANSISTOR 2SK30A
Q120	8-729-663-47	TRANSISTOR 2SC1364

NOTE:

- Items with no part number and no description are not stocked because they are seldom required for routine service.
- Items marked "▲" are not stocked since they are seldom required for routine service. Some delay should be anticipated when ordering these items.
- Due to standardization, parts with part numbers (▲-▲▲▲-▲▲▲-XX or ▲-▲▲▲-▲▲▲-X) may be different from those used in the set.

CAPACITORS:

- All capacitors are in μF . Common capacitors are omitted. Refer to the following lists for their part numbers. MF: μF , PF: μF .

RESISTORS

- All resistors are in ohms. Common 1/4W, 1/8W and 1/16W carbon resistors are omitted. Refer to the following lists for their part numbers.

- F: nonflammable

COILS

- MMH: mH, UH: μH

The components identified by shading and mark ▲ are critical for safety. Replace only with part number specified.

Les composants identifiés par une trame et une marque ▲ sont critiques pour la sécurité. Ne les remplacer que par une pièce portant le numéro spécifié.

ELECTRICAL PARTS

Ref.No.	Part No.	Description
Q121	8-729-203-02	TRANSISTOR 2SK30A
Q122	8-729-203-02	TRANSISTOR 2SK30A
Q123	8-729-283-42	TRANSISTOR 2SB834
Q124	8-729-203-02	TRANSISTOR 2SK30A
Q125	8-729-203-02	TRANSISTOR 2SK30A
Q126	8-729-203-02	TRANSISTOR 2SK30A
Q127	8-729-203-02	TRANSISTOR 2SK30A
Q128	8-729-180-93	TRANSISTOR 2SD809
Q129	8-729-173-13	TRANSISTOR 2SB731
Q130	8-729-203-02	TRANSISTOR 2SK30A
Q131	8-729-203-02	TRANSISTOR 2SK30A
Q132	8-729-180-93	TRANSISTOR 2SD809
Q133	8-729-173-13	TRANSISTOR 2SB731
Q134	8-729-663-47	TRANSISTOR 2SC1364
Q135	8-729-663-47	TRANSISTOR 2SC1364
Q136	8-729-663-47	TRANSISTOR 2SC1364
Q137	8-729-663-47	TRANSISTOR 2SC1364
Q138	8-729-663-47	TRANSISTOR 2SC1364
Q201	8-729-612-77	TRANSISTOR 2SA1027R
Q202	8-729-663-47	TRANSISTOR 2SC1364
Q203	8-729-663-47	TRANSISTOR 2SC1364
Q204	8-729-663-47	TRANSISTOR 2SC1364
Q205	8-729-663-47	TRANSISTOR 2SC1364
Q206	8-729-180-93	TRANSISTOR 2SD809
Q207	8-729-173-13	TRANSISTOR 2SB731
Q208	8-729-180-93	TRANSISTOR 2SD809
Q209	8-729-173-13	TRANSISTOR 2SB731
Q301	8-729-663-47	TRANSISTOR 2SC1364
Q302	8-729-663-47	TRANSISTOR 2SC1364
Q303	8-729-663-47	TRANSISTOR 2SC1364
Q304	8-729-663-47	TRANSISTOR 2SC1364
Q305	8-729-663-47	TRANSISTOR 2SC1364
Q306	8-729-663-47	TRANSISTOR 2SC1364
Q307	8-729-663-47	TRANSISTOR 2SC1364
Q308	8-729-663-47	TRANSISTOR 2SC1364
Q309	8-729-663-47	TRANSISTOR 2SC1364
Q310	8-729-612-77	TRANSISTOR 2SA1027R
Q311	8-729-663-47	TRANSISTOR 2SC1364
Q312	8-729-663-47	TRANSISTOR 2SC1364
Q313	8-729-663-47	TRANSISTOR 2SC1364
Q314	8-729-612-77	TRANSISTOR 2SA1027R
Q315	8-729-663-47	TRANSISTOR 2SC1364
Q316	8-729-612-77	TRANSISTOR 2SA1027R
Q317	8-729-663-47	TRANSISTOR 2SC1364
Q318	8-729-663-47	TRANSISTOR 2SC1364
Q319	8-729-612-77	TRANSISTOR 2SA1027R
Q320	8-729-663-47	TRANSISTOR 2SC1364
Q321	8-729-612-77	TRANSISTOR 2SA1027R
Q322	8-729-663-47	TRANSISTOR 2SC1364
Q323	8-729-612-77	TRANSISTOR 2SA1027R

NOTE:

- Items with no part number and no description are not stocked because they are seldom required for routine service.
- Items marked "▲" are not stocked since they are seldom required for routine service. Some delay should be anticipated when ordering these items.
- Due to standardization, parts with part numbers (Δ-ΔΔΔ-ΔΔΔ-XX or Δ-ΔΔΔΔ-ΔΔΔ-X) may be different from those used in the set.

ELECTRICAL PARTS

Ref.No.	Part No.	Description
Q324	8-729-663-47	TRANSISTOR 2SC1364
Q401	8-729-180-93	TRANSISTOR 2SD809
Q402	8-729-173-13	TRANSISTOR 2SB731
Q403	8-729-180-93	TRANSISTOR 2SD809
Q404	8-729-173-13	TRANSISTOR 2SB731
Q501	8-729-663-47	TRANSISTOR 2SC1364
Q502	8-729-663-47	TRANSISTOR 2SC1364
Q503	8-729-180-93	TRANSISTOR 2SD809
Q504	8-729-173-13	TRANSISTOR 2SB731
Q505	8-729-180-93	TRANSISTOR 2SD809
Q506	8-729-173-13	TRANSISTOR 2SB731
Q601	8-729-288-02	TRANSISTOR 2SD880
Q602	8-729-663-47	TRANSISTOR 2SC1364
Q603	8-729-663-47	TRANSISTOR 2SC1364
Q604	8-729-288-02	TRANSISTOR 2SD880
Q605	8-729-203-02	TRANSISTOR 2SK30A
Q606	8-729-663-47	TRANSISTOR 2SC1364
Q607	8-729-663-47	TRANSISTOR 2SC1364
Q608	8-729-612-77	TRANSISTOR 2SA1027R
Q609	8-729-612-77	TRANSISTOR 2SA1027R
Q610	8-729-203-02	TRANSISTOR 2SK30A
Q611	8-729-283-42	TRANSISTOR 2SB834
Q612	8-729-663-47	TRANSISTOR 2SC1364
Q613	8-729-663-47	TRANSISTOR 2SC1364
Q614	8-729-663-47	TRANSISTOR 2SC1364
Q615	8-729-663-47	TRANSISTOR 2SC1364
Q616	8-729-663-47	TRANSISTOR 2SC1364
Q701	8-729-612-77	TRANSISTOR 2SA1027R
Q702	8-729-663-47	TRANSISTOR 2SC1364
Q703	8-729-663-47	TRANSISTOR 2SC1364
Q704	8-729-663-47	TRANSISTOR 2SC1364
Q705	8-729-663-47	TRANSISTOR 2SC1364
Q706	8-729-180-93	TRANSISTOR 2SD809
Q707	8-729-173-13	TRANSISTOR 2SB731
Q708	8-729-180-93	TRANSISTOR 2SD809
Q709	8-729-173-13	TRANSISTOR 2SB731
Q801	8-729-101-01	TRANSISTOR PH101
Q802	8-729-101-01	TRANSISTOR PH101
R601	▲ 1-206-471-00	METAL 22 5% 2W F
R602	▲ 1-213-036-00	FUSIBLE 1 5% 1W F
R603	▲ 1-213-036-00	FUSIBLE 1 5% 1W F
R604	▲ 1-206-471-00	METAL 22 5% 2W F
R613	▲ 1-206-477-00	METAL 39 5% 2W F
R617	▲ 1-212-934-51	FUSIBLE 1 5% 1/2W F
R622	▲ 1-212-934-51	FUSIBLE 1 5% 1/2W F
R731	▲ 1-244-857-00	CARBON 220 5% 1/2W F
R909	▲ 1-212-372-00	METAL 10 5% 1W F
R944	▲ 1-244-831-00	CARBON 18 5% 1/2W
R958	▲ 1-244-831-00	CARBON 18 5% 1/2W

CAPACITORS:

- All capacitors are in μF . Common capacitors are omitted. Refer to the following lists for their part numbers.
MF: μF , PF: μmF .

RESISTORS

- All resistors are in ohms. Common 1/4W, 1/8W and 1/16W carbon resistors are omitted. Refer to the following lists for their part numbers.

* F : nonflammable

COILS

- MMH : mH, UH : μH

The components identified by shading and mark ▲ are critical for safety. Replace only with part number specified.

Les composants identifiés par une trame et une marque ▲ sont critiques pour la sécurité. Ne les remplacer que par une pièce portant le numéro spécifié.

ELECTRICAL PARTS

Ref.No.	Part No.	Description
RV101	1-224-489-00	RES, ADJ, METAL FILM 2.2K
RV102	1-224-661-00	RES, ADJ, METAL FILM 47K
RV103	1-224-491-00	RES, ADJ, METAL FILM 22K
RV104	1-224-256-XX	RES, ADJ, METAL GLAZE 220K
RV105	1-224-256-XX	RES, ADJ, METAL GLAZE 220K
RV106	1-224-254-XX	RES, ADJ, METAL GLAZE 47K
RV107	1-224-489-00	RES, ADJ, METAL FILM 2.2K
RV108	1-224-661-00	RES, ADJ, METAL FILM 47K
RV109	1-224-252-XX	RES, ADJ, METAL GLAZE 10K
RV110	1-224-254-XX	RES, ADJ, METAL GLAZE 47K
RV111	1-224-254-XX	RES, ADJ, METAL GLAZE 47K
RV112	1-224-491-00	RES, ADJ, METAL FILM 22K
RV113	1-224-661-00	RES, ADJ, METAL FILM 47K
RV301	1-224-256-XX	RES, ADJ, METAL GLAZE 220K
RV302	1-224-255-XX	RES, ADJ, METAL GLAZE 100K
RV303	1-224-254-XX	RES, ADJ, METAL GLAZE 47K
RV304	1-224-254-XX	RES, ADJ, METAL GLAZE 47K
RV401	1-226-235-00	RES, ADJ, CARBON 5K
RV402	1-226-235-00	RES, ADJ, CARBON 5K
RV403	1-226-237-00	RES, ADJ, CARBON 20K
RV404	1-226-237-00	RES, ADJ, CARBON 20K
RV501	1-226-235-00	RES, ADJ, CARBON 5K
RV502	1-226-235-00	RES, ADJ, CARBON 5K
RV503	1-226-237-00	RES, ADJ, CARBON 20K
RV504	1-226-237-00	RES, ADJ, CARBON 20K
RV701	1-224-661-00	RES, ADJ, METAL FILM 47K
RV702	1-224-492-00	RES, ADJ, METAL FILM 100K
RV703	1-226-236-00	RES, ADJ, CARBON 10K
RV704	1-226-236-00	RES, ADJ, CARBON 10K
RV705	1-226-236-00	RES, ADJ, CARBON 10K
RV706	1-226-236-00	RES, ADJ, CARBON 10K
RV901	1-228-008-00	RES VARIABLE 1K (B)
RV902	1-224-488-00	RES, ADJ, METAL FILM 470
RV903	1-224-661-00	RES, ADJ, METAL FILM 47K
RV904	1-226-234-00	RES, ADJ, CARBON 2K
RV905	1-226-234-00	RES, ADJ, CARBON 2K
RY101	1-515-323-00	RELAY
RY801	1-515-323-00	RELAY
S101	1-553-606-00	SWITCH
S102	1-553-606-00	SWITCH
S801	1-553-580-00	SWITCH, KEY BOARD
S802	1-553-580-00	SWITCH, KEY BOARD
S803	1-553-580-00	SWITCH, KEY BOARD
S804	1-553-580-00	SWITCH, KEY BOARD
S805	1-553-580-00	SWITCH, KEY BOARD
S806	1-553-580-00	SWITCH, KEY BOARD
S807	1-553-580-00	SWITCH, KEY BOARD

ELECTRICAL PARTS

Ref.No.	Part No.	Description
S808	▲ 1-553-318-00	(E,AEP,UK).....SWITCH, PUSH (AC POWER)
S808	▲ 1-553-319-00	(US,Canadian)...SWITCH, PUSH (AC POWER)
S809	▲ 1-552-535-00	(E).....SWITCH, POWER VOLTAGE CHANGE
T801	▲ 1-447-043-00	(US,Canadian)...TRANSFORMER, POWER
T801	▲ 1-447-127-00	(AEP,UK).....TRANSFORMER, POWER
T801	▲ 1-447-128-00	(E).....TRANSFORMER, POWER
T802	▲ 1-446-955-21	(E).....TRANSFORMER, POWER
T802	▲ 1-446-957-21	(AEP,UK).....TRANSFORMER, POWER
T802	▲ 1-446-956-21	(US,Canadian)...TRANSFORMER, POWER
TH101	1-800-202-XX	THERMISTOR S-10K
X201	1-527-482-00	RADIATOR, CRYSTAL
X701	1-527-380-00	CRYSTAL, OSC

NOTE:

- Items with no part number and no description are not stocked because they are seldom required for routine service.
- Items marked "▲" are not stocked since they are seldom required for routine service. Some delay should be anticipated when ordering these items.
- Due to standardization, parts with part numbers (▲-△△△-△△△-XX or ▲-△△△△-△△△-X) may be different from those used in the set.

CAPACITORS:

- All capacitors are in μF . Common capacitors are omitted. Refer to the following lists for their part numbers. MF: μF , PF: μF .

RESISTORS

- All resistors are in ohms. Common 1/4W, 1/8W and 1/16W carbon resistors are omitted. Refer to the following lists for their part numbers.

- F : nonflammable

COILS

- MMH : mH, UH : μH

The components identified by shading and mark ▲ are critical for safety. Replace only with part number specified.

Les composants identifiés par une trame et une marque ▲ sont critiques pour la sécurité. Ne les remplacer que par une pièce portant le numéro spécifié.

MEMO

A series of horizontal dotted lines for writing.

ELECTROLYTIC CAPACITORS

RATING → : Use the high voltage rated one.						
CAP. (μF)	6.3 VOLT.	10 VOLT.	16 VOLT.	25 VOLT.	35 VOLT.	50 VOLT.
	PART No.	PART No.	PART No.	PART No.	PART No.	PART No.
0.47					→	1-121-726-00
1.0					→	1-121-391-00
2.2					→	1-121-450-00
3.3	→	→	→	1-121-392-00	→	1-121-393-00
4.7	→	→	→	1-121-395-00	→	1-121-396-00
10	→	→	1-121-651-00	1-121-398-00	→	1-121-738-00
22	→	→	1-121-479-00	1-121-480-00	1-121-662-00	1-121-152-00
33	→	→	1-121-403-00	1-121-404-00	1-121-652-00	1-121-405-00
47	→	1-121-352-00	1-121-409-00	1-121-410-00	1-121-653-00	1-121-411-00
100	→	1-121-414-00	1-121-415-00	1-121-416-00	1-121-357-00	1-121-417-00
220	1-121-417-00	1-121-420-00	1-121-421-00	1-121-422-00	1-121-261-00	1-121-423-00
330	1-121-751-00	1-121-805-00	1-121-521-00	1-121-654-00	1-121-655-00	1-121-656-00
470	1-121-424-00	1-121-425-00	1-121-426-00	1-121-733-00	1-121-361-00	1-121-810-00
1000		1-121-736-00	1-121-245-00	1-121-657-00	1-121-388-00	1-123-061-00
2200	1-121-658-00	1-121-659-00	1-121-660-00	1-123-067-00	1-121-984-00	
3300	1-121-661-00	1-123-075-00	1-123-071-00			

CAP. (μF)	100 VOLT.	160 VOLT.	250 VOLT.	350 VOLT.
	PART No.	PART No.	PART No.	PART No.
0.47				
1.0	1-123-249-00	1-123-252-00	1-123-003-00	1-121-168-00
2.2	1-123-250-00	1-123-026-00		1-123-028-00
3.3	1-121-995-00		1-123-004-00	1-123-006-00
4.7	1-123-255-00	1-121-246-00	1-121-759-00	1-123-007-00
10	1-121-126-00	1-121-999-00	1-123-254-00	1-123-008-00
22	1-121-996-00	1-123-253-00	1-123-005-00	1-123-022-00
33	1-121-997-00	1-121-757-00		
47	1-123-251-00	1-121-919-00		
100	1-123-084-00			

CERAMIC CAPACITORS

RATING							
CAP. (pF)	50 VOLT.	CAP. (pF)	50 VOLT.	CAP. (pF)	50 VOLT.	CAP. (μF)	50 VOLT.
	PART No.		PART No.		PART No.		PART No.
0.5	1-101-837-00	22	1-102-959-00	150	1-101-361-00	0.001	1-102-074-00
0.75	1-101-586-00	24	1-102-960-00	160	1-101-367-00	0.0012	1-102-118-00
1.0	1-102-934-00	27	1-102-961-00	180	1-102-976-00	0.0015	1-102-119-00
1.5	1-101-576-00	30	1-102-962-00	200	1-102-977-00	0.0018	1-102-120-00
2.0	1-102-935-00	33	1-102-963-00	220	1-102-978-00	0.0022	1-102-121-00
3	1-102-936-00	36	1-102-964-00	240	1-102-979-00	0.0027	1-102-122-00
4	1-102-937-00	39	1-102-965-00	270	1-102-980-00	0.0033	1-102-123-00
5	1-102-942-00	43	1-102-966-00	300	1-102-981-00	0.0039	1-102-124-00
6	1-102-943-00	47	1-101-880-00	330	1-102-820-00	0.0047	1-102-125-00
7	1-102-944-00	51	1-101-882-00	360	1-102-821-00	0.0056	1-102-126-00
8	1-102-945-00	56	1-101-884-00	390	1-102-822-00	0.0068	1-102-127-00
9	1-102-946-00	62	1-101-886-00	430	1-102-823-00	0.0082	1-102-128-00
10	1-102-947-00	68	1-101-888-00	470	1-102-824-00	0.01	1-102-129-00
11	1-102-948-00	75	1-101-890-00	510	1-101-059-00	0.022	1-101-005-00
12	1-102-949-00	82	1-102-971-00	560	1-102-115-00	0.047	1-101-006-00
13	1-102-950-00	91	1-102-972-00	680	1-102-116-00		
15	1-102-951-00	100	1-102-973-00	820	1-102-117-00		
16	1-102-952-00	110	1-102-815-00				
18	1-102-953-00	120	1-102-816-00				
20	1-102-958-00	130	1-101-081-00				

0.001μF = 1,000pF

CERAMIC (SEMICONDUCTOR) CAPACITORS

RATING → : Use the high voltage rated one.					
CAP. (μF)	25 VOLT.	50 VOLT.	CAP. (μF)	25 VOLT.	50 VOLT.
	PART No.	PART No.		PART No.	PART No.
0.001	→	1-161-039-00	0.018	1-161-016-00	1-161-054-00
0.0012	→	1-161-040-00	0.022	1-161-017-00	1-161-055-00
0.0015		1-161-041-00	0.027	1-161-018-00	1-161-056-00
0.0018		1-161-042-00	0.033	1-161-019-00	1-161-057-00
0.0022		1-161-043-00	0.039	1-161-010-00	1-161-058-00
0.0027	→	1-161-044-00	0.047	1-161-021-00	1-161-059-00
0.0033	→	1-161-045-00	0.056	→	1-161-060-00
0.0039	→	1-161-046-00	0.068	→	1-161-061-00
0.0047	→	1-161-047-00	0.082	1-161-024-00	1-161-062-00
0.0056	→	1-161-048-00	0.1	1-161-025-00	1-161-063-00
0.0068	→	1-161-049-00			
0.0082	1-161-012-00	1-161-050-00			
0.01	1-161-013-00	1-161-051-00			
0.012	→	1-161-052-00			
0.015	1-161-015-00	1-161-053-00			

MYLAR CAPACITORS

RATING													
CAP. (μF)	50 VOLT.			100 VOLT.			200 VOLT.			CAP. (μF)	50 VOLT.		
	PART No.	PART No.	PART No.	PART No.	PART No.	PART No.	PART No.	PART No.	PART No.		PART No.	PART No.	
0.001	1-108-227-00	1-108-365-00	1-108-409-00	0.01	1-108-239-00	1-108-377-00	1-108-421-00	0.1	1-108-251-00	1-108-389-00	1-108-433-00		
0.0012	1-108-351-00	1-108-366-00	1-108-410-00	0.012	1-108-357-00	1-108-378-00	1-108-422-00	0.12	1-108-363-00	1-108-390-00	1-108-434-00		
0.0015	1-108-228-00	1-108-367-00	1-108-411-00	0.015	1-108-240-00	1-108-379-00	1-108-423-00	0.15	1-108-252-00	1-108-391-00	1-108-435-00		
0.0018	1-108-352-00	1-108-368-00	1-108-412-00	0.018	1-108-358-00	1-108-380-00	1-108-424-00	0.18	1-108-364-00	1-108-392-00	1-108-436-00		
0.0022	1-108-230-00	1-108-369-00	1-108-413-00	0.022	1-108-242-00	1-108-381-00	1-108-425-00	0.22	1-108-254-00	1-108-393-00	1-108-437-00		
0.0027	1-108-353-00	1-108-370-00	1-108-414-00	0.027	1-108-359-00	1-108-382-00	1-108-426-00	0.27	1-108-854-00	-	-		
0.0033	1-108-232-00	1-108-371-00	1-108-415-00	0.033	1-108-244-00	1-108-383-00	1-108-427-00	0.33	1-108-855-00	-	-		
0.0039	1-108-354-00	1-108-372-00	1-108-416-00	0.039	1-108-360-00	1-108-384-00	1-108-428-00	0.39	1-108-856-00	-	-		
0.0047	1-108-234-00	1-108-373-00	1-108-417-00	0.047	1-108-246-00	1-108-385-00	1-108-429-00	0.47	1-108-857-00	-	-		
0.0056	1-108-355-00	1-108-374-00	1-108-418-00	0.056	1-108-361-00	1-108-386-00	1-108-430-00	-	-	-	-		
0.0068	1-108-237-00	1-108-375-00	1-108-419-00	0.068	1-108-249-00	1-108-387-00	1-108-431-00	-	-	-	-		
0.0082	1-108-356-00	1-108-376-00	1-108-420-00	0.082	1-108-362-00	1-108-388-00	1-108-432-00	-	-	-	-		



TANTALUM CAPACITORS

RATING								→ : Use the high voltage rated one.		
CAP. (μF)	3.15 VOLT.		6.3 VOLT.		10 VOLT.		16 VOLT.		20 VOLT.	
	PART No.	PART No.	PART No.	PART No.	PART No.	PART No.	PART No.	PART No.	PART No.	PART No.
0.01									→	1-131-396-00
0.015									→	1-131-397-00
0.022									→	1-131-398-00
0.033									→	1-131-399-00
0.047									→	1-131-400-00
0.068									→	1-131-401-00
0.1									→	1-131-402-00
0.15									→	1-131-403-00
0.22									→	1-131-404-00
0.33									→	1-131-405-00
0.47								1-131-412-00	→	1-131-406-00
0.68						1-131-415-00		→	1-131-410-00	1-131-407-00
1.0					1-131-418-00			1-131-413-00	→	1-131-408-00
1.5			1-131-421-00			1-131-416-00		→	1-131-411-00	1-131-348-00
2.2	1-131-424-00			1-131-419-00				1-131-414-00	1-131-355-00	1-131-349-00
3.3		1-131-422-00			1-131-417-00			1-131-362-00	1-131-356-00	1-131-350-00
4.7	1-131-425-00			1-131-420-00	1-131-369-00			1-131-363-00	1-131-357-00	1-131-351-00
6.8		1-131-423-00		1-131-376-00	1-131-370-00			1-131-364-00	1-131-358-00	1-131-352-00
10	1-131-426-00	1-131-383-00		1-131-377-00	1-131-371-00			1-131-365-00	1-131-359-00	1-131-353-00
15	1-131-390-00	1-131-384-00		1-131-378-00	1-131-372-00			1-131-366-00	1-131-360-00	
22	1-131-391-00	1-131-385-00		1-131-379-00	1-131-373-00			1-131-367-00		
33	1-131-392-00	1-131-386-00		1-131-380-00	1-131-374-00					
47	1-131-393-00	1-131-387-00		1-131-381-00						
68	1-131-394-00	1-131-388-00								
100	1-131-395-00									



TANTALUM CAPACITORS

RATING						
CAP. (μF)	3 VOLT.		6.3 VOLT.		10 VOLT.	
	PART No.	PART No.	PART No.	PART No.	PART No.	PART No.
0.033						1-131-273-00
0.047						1-131-274-00
0.068						1-131-275-00
0.1						1-131-276-00
0.15						1-131-277-00
0.22						1-131-278-00
0.33						1-131-279-00
0.47				1-131-169-00		1-131-280-00
0.68					1-131-258-00	1-131-281-00
1.0				1-131-254-00		1-131-282-00
1.5			1-131-250-00			1-131-283-00
2.2					1-131-259-00	1-131-284-00
3.3				1-131-255-00		
4.7			1-131-251-00	1-131-171-00		
6.8					1-131-260-00	1-131-271-00
10				1-131-256-00		1-131-272-00
15					1-131-261-00	
22				1-131-257-00		
33	1-131-176-00		1-131-253-00	1-131-173-00		
47	1-131-288-00		1-131-174-00			
100	1-131-177-00					

1/4 WATT CARBON RESISTORS

Ω	Part No.	Ω	Part No.	Ω	Part No.	Ω	Part No.	Ω	Part No.	Ω	Part No.	Ω	Part No.
1.0	1-246-401-00	10	1-246-425-00	100	1-246-449-00	1.0k	1-246-473-00	10k	1-246-497-00	100k	1-246-521-00	1.0M	1-246-545-00
1.1	1-246-402-00	11	1-246-426-00	110	1-246-450-00	1.1k	1-246-474-00	11k	1-246-498-00	110k	1-246-522-00	1.1M	1-210-814-00
1.2	1-246-403-00	12	1-246-427-00	120	1-246-451-00	1.2k	1-246-475-00	12k	1-246-499-00	120k	1-246-523-00	1.2M	1-210-815-00
1.3	1-246-404-00	13	1-246-428-00	130	1-246-452-00	1.3k	1-246-476-00	13k	1-246-500-00	130k	1-246-524-00	1.3M	1-210-816-00
1.5	1-246-405-00	15	1-246-429-00	150	1-246-453-00	1.5k	1-246-477-00	15k	1-246-501-00	150k	1-246-525-00	1.5M	1-210-817-00
1.6	1-246-406-00	16	1-246-430-00	160	1-246-454-00	1.6k	1-246-478-00	16k	1-246-502-00	160k	1-246-526-00	1.6M	1-210-818-00
1.8	1-246-407-00	18	1-246-431-00	180	1-246-455-00	1.8k	1-246-479-00	18k	1-246-503-00	180k	1-246-527-00	1.8M	1-210-819-00
2.0	1-246-408-00	20	1-246-432-00	200	1-246-456-00	2.0k	1-246-480-00	20k	1-246-504-00	200k	1-246-528-00	2.0M	1-210-820-00
2.2	1-246-409-00	22	1-246-433-00	220	1-246-457-00	2.2k	1-246-481-00	22k	1-246-505-00	220k	1-246-529-00	2.2M	1-210-821-00
2.4	1-246-410-00	24	1-246-434-00	240	1-246-458-00	2.4k	1-246-482-00	24k	1-246-506-00	240k	1-246-530-00	2.4M	1-244-754-00
2.7	1-246-411-00	27	1-246-435-00	270	1-246-459-00	2.7k	1-246-483-00	27k	1-246-507-00	270k	1-246-531-00	2.7M	1-244-755-00
3.0	1-246-412-00	30	1-246-436-00	300	1-246-460-00	3.0k	1-246-484-00	30k	1-246-508-00	300k	1-246-532-00	3.0M	1-244-756-00
3.3	1-246-413-00	33	1-246-437-00	330	1-246-461-00	3.3k	1-246-485-00	33k	1-246-509-00	330k	1-246-533-00	3.3M	1-244-757-00
3.6	1-246-414-00	36	1-246-438-00	360	1-246-462-00	3.6k	1-246-486-00	36k	1-246-510-00	360k	1-246-534-00	3.6M	1-244-758-00
3.9	1-246-415-00	39	1-246-439-00	390	1-246-463-00	3.9k	1-246-487-00	39k	1-246-511-00	390k	1-246-535-00	3.9M	1-244-759-00
4.3	1-246-416-00	43	1-246-440-00	430	1-246-464-00	4.3k	1-246-488-00	43k	1-246-512-00	430k	1-246-536-00	4.3M	1-244-760-00
4.7	1-246-417-00	47	1-246-441-00	470	1-246-465-00	4.7k	1-246-489-00	47k	1-246-513-00	470k	1-246-537-00	4.7M	1-244-761-00
5.1	1-246-418-00	51	1-246-442-00	510	1-246-466-00	5.1k	1-246-490-00	51k	1-246-514-00	510k	1-246-538-00	5.1M	1-244-762-00
5.6	1-246-419-00	56	1-246-443-00	560	1-246-467-00	5.6k	1-246-491-00	56k	1-246-515-00	560k	1-246-539-00		
6.2	1-246-420-00	62	1-246-444-00	620	1-246-468-00	6.2k	1-246-492-00	62k	1-246-516-00	620k	1-246-540-00		
6.8	1-246-421-00	68	1-246-445-00	680	1-246-469-00	6.8k	1-246-493-00	68k	1-246-517-00	680k	1-246-541-00		
7.5	1-246-422-00	75	1-246-446-00	750	1-246-470-00	7.5k	1-246-494-00	75k	1-246-518-00	750k	1-246-542-00		
8.2	1-246-423-00	82	1-246-447-00	820	1-246-471-00	8.2k	1-246-495-00	82k	1-246-519-00	820k	1-246-543-00		
9.1	1-246-424-00	91	1-246-448-00	910	1-246-472-00	9.1k	1-246-496-00	91k	1-246-520-00	910k	1-246-544-00		

HARDWARE NOMENCLATURE

Screw:

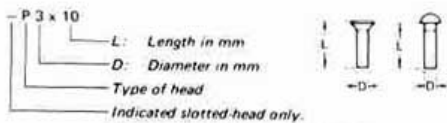

Indicated slotted-head only.
Unless otherwise indicated, it means cross-recessed head (Phillips type).

Nut, Washer, Retaining ring:

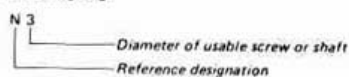

Reference Designation	Shape	Description	Remarks
SCREWS			
P		pan-head screw	binding-head (B) screw for replacement
PWH		pan-head screw with washer face	binding-head (B) screw and flat washer for replacement
PS PSP		pan-head screw with spring washer	binding-head (B) screw and spring washer for replacement
PSW PSPW		pan-head screw with spring and flat washers	binding-head (B) screw and spring and flat washers for replacement
R		round-head screw	binding-head (B) screw for replacement
K		flat-countersunk-head screw	
RK		oval-countersunk-head screw	
B		binding-head screw	
T		truss-head screw	binding-head (B) screw for replacement
F		flat-fillister-head screw	
RF		fillister-head screw	
BV		brazer-head screw	

Reference Designation	Shape	Description	Remarks
SELF TAPPING SCREWS			
TA		self-tapping screw	ex: TA, P 3 x 10
PTP		pan-head self-tapping screw	binding-head self-tapping (TA, B) screw for replacement
PTPWH		pan-head self-tapping screw with washer face	binding-head self-tapping (TA, B) screw and flat washer for replacement
PTTWH		pan-head thread-rolling screw with washer face	binding-head (B) screw and flat washer for replacement
SET SCREWS			
SC		set screw	
SC		hexagon-socket set screw	ex: SC 2.6 x 4, hexagon socket
NUT			
N		nut	
WASHERS			
W		flat washer	
SW		spring washer	
LW		internal-tooth lock washer	ex: LW3, internal
LW		external-tooth lock washer	ex: LW3, external
RETAINING RINGS			
E		retaining ring	
G		grip-type retaining ring	

