



# MC 2002

POWER AMPLIFIER

**McIntosh<sup>®</sup>**  
OWNERS MANUAL

- 15. Nonuse Periods - Unplug the power cord from the AC power outlet when left unused for a long period of time.
- 16. Damage Requiring Service - **Service must be performed by qualified service personnel when:**
  - A. The power supply cord or the plug has been damaged; or
  - B. Objects have fallen, or liquid has been spilled into the instrument; or
  - C. The instrument has been exposed to rain; or
  - D. The instrument does not appear to operate normally or exhibits a marked change in performance; or
  - E. The instrument has been dropped, or the enclosure damaged.
- 17. Servicing - Do not attempt to service beyond that described in the operating instructions. All other service should be referred to qualified service personnel.
- 18. Grounding or Polarization - Do not defeat the inherent design features of the polarized plug. Non-polarized line cord adaptors will defeat the safety provided by the polarized AC plug.

19. **CAUTION: TO PREVENT ELECTRICAL SHOCK DO NOT USE THIS (POLARIZED) PLUG WITH AN EXTENSION CORD, RECEPTACLE OR OTHER OUTLET UNLESS THE BLADES CAN BE FULLY INSERTED TO PREVENT BLADE EXPOSURE.**

Note to CATV system installer:

This reminder is provided to call the CATV system installer's attention to Article 820-22 of the NEC that provides guidelines for proper grounding and, in particular, specifies that the cable ground shall be connected to the grounding system of the building, as close to the point of cable entry as practical.

**ATTENTION: POUR PREVENIR LES CHOCS ELECTRIQUES PAS UTILISER CETTE FICHE POLARISEE AVEC UN PROLONGATEUR, UNE PRISE DE COURANT OU UNE AUTRE SORTIE DE COURANT, SAUF SI LES LAMES PEUVENT ETRE INSEREES A FOND SANS EN LAISSER AUCUNE PARTIE A DECOUVERT.**



The lightning flash with arrowhead, within an equilateral triangle, is intended to alert the user to the presence of uninsulated "dangerous voltage" within the product's enclosure that may be of sufficient magnitude to constitute a risk of electric shock to persons.



CAUTION: TO PREVENT THE RISK OF ELECTRIC SHOCK, DO NOT REMOVE COVER (OR BACK). NO USER-SERVICABLE PARTS INSIDE. REFER SERVICING TO QUALIFIED PERSONNEL.



The exclamation point within an equilateral triangle is intended to alert the user to the presence of important operating and maintenance (servicing) instructions in the literature accompanying the appliance.

The serial number, purchase date, and McIntosh Laboratory Service Contract number are important to you for possible insurance claim or future service. Record this information here.

Serial Number

Purchase Date

Service Contract Number

Upon application, McIntosh Laboratory provides a Service Contract to the original purchaser. Your McIntosh Authorized Service Agency can expedite repairs when you provide the Service Contract with the instrument for repair.

# IMPORTANT SAFETY INSTRUCTIONS

**THESE INSTRUCTIONS ARE TO PROTECT YOU AND THE McINTOSH INSTRUMENT. BE SURE TO FAMILIARIZE YOURSELF WITH THEM.**

1. Read all instructions - Read the safety and operating instructions before operating the instrument.
2. Retain Instructions - Retain the safety and operating instructions for future reference.
3. Heed warnings - Adhere to warnings and operating instructions.
4. Follow Instructions - Follow all operating and use instructions.

**WARNING: TO REDUCE RISK OF FIRE OR ELECTRICAL SHOCK, DO NOT EXPOSE THIS INSTRUMENT TO RAIN OR MOISTURE.**

5. Power Sources - Connect the power supply only to the type described in the operating instructions or as marked on the unit.
6. Power-Cord Protection - Route power-supply cords so that they are not likely to be walked on or pinched by items placed upon or against them, paying particular attention to cords at plugs, convenience receptacles, and the point where they exit from the instrument.
7. Ventilation - Locate the instrument for proper ventilation. For example, the instrument should not be placed on a bed, sofa, rug, or similar surface that may block ventilation openings; or, placed in a built-in installation, such as a bookcase or cabinet, that may impede the flow of air through the ventilation openings.
8. Heat - Locate the instrument away from heat sources such as radiators, heat registers, stoves, or other appliance (including amplifiers) that produce heat.
9. Wall or Cabinet Mounting - Mount the instrument in a wall or cabinet only as described in the owners manual.
10. Water and Moisture - Do not use the instrument near water - for example, near a bathtub, washbowl, kitchen sink, laundry tub, in a wet basement, or near a swimming pool, etc.
11. Cleaning - Clean the instrument by dusting with a dry cloth. Clean the panel with a cloth moistened with a window cleaner.
12. Object and Liquid Entry - Do not permit objects to fall and liquids to spill into the instrument through enclosure openings.

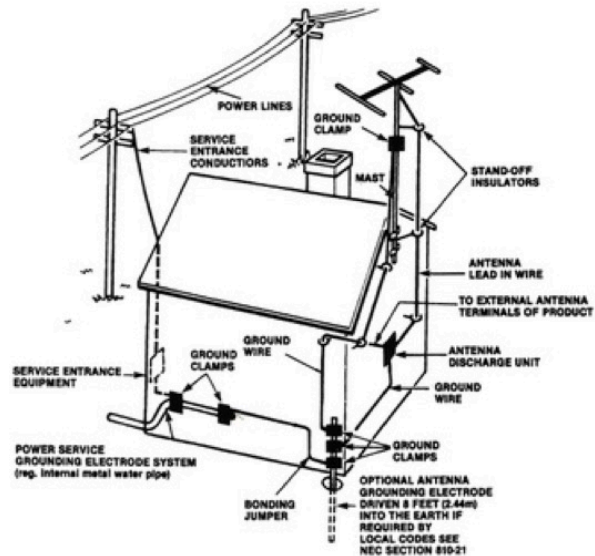

13. Power Lines - Locate any outdoor antenna away from power lines.
14. Outdoor Antenna Grounding - If an outdoor antenna is connected to the antenna terminal, be sure the antenna system is grounded to provide some protection against voltage surges and built up static charge.

In the U.S.A., section 810 of the National Electrical Code, ANSI/NFPA No. 70-1987, provides information on the proper ground for the mast and supporting structure, ground for the lead-in wire to an antenna discharge unit, and size of ground conductors, location of antenna-discharge unit, connection to grounding electrodes, and requirements for the grounding electrode.

For ground wire:

- a) Use No. 10 AWG (5.3 mm<sup>2</sup>) copper No. 8 AWG (8.4 mm<sup>2</sup>) aluminum, No. 17 AWG (1.0 mm<sup>2</sup>) copper-clad steel, bronze wire, or larger as ground wire.
- b) Secure antenna lead-in and ground wires to house with stand-off insulators spaced from 4 feet (1.22 meters) to 6 feet (1.83 meters) apart.
- c) Mount antenna discharge unit as closely as possible to where lead-in enters house.
- d) Use jumper wire not smaller than No. 6 AWG (13.3 mm<sup>2</sup>) copper or equivalent when separate antenna grounding electrode is used.



Your MC 2002 Stereo Power Amplifier will give you many years of pleasant and satisfactory performance. If you have any questions, please contact:

#### CUSTOMER SERVICE

McIntosh Laboratory Inc.  
2 Chambers Street  
Binghamton, New York 13903-2699  
Phone: 607-723-3512

**Take Advantage of 3 years  
of Contract Service . . .  
Fill in the Application NOW.**

## Contents

INSTALLATION . . .	2,3
HOW TO CONNECT . . .	4,5,6
FRONT PANEL FEATURES . . .	7
REAR PANEL INFORMATION . . .	8
PERFORMANCE LIMITS . . .	9
PERFORMANCE CHARTS . . .	10,11
TECHNICAL DESCRIPTION . . .	12,13
BLOCK DIAGRAM . . .	14

### McINTOSH THREE YEAR SERVICE CONTRACT

An application for A THREE YEAR SERVICE CONTRACT is included with this manual.

The terms of the contract are:

1. If the instrument covered by this contract becomes defective, McIntosh will provide all parts, materials, and labor needed to return the measured performance of the instrument to the original performance limits free of any charge. The service contract does not cover any shipping costs to and from the authorized service agency or the factory.
2. Any McIntosh authorized service agency will repair all McIntosh instruments at normal service rates. To receive the free service under the terms of the service contract, the service contract certificate must accompany the instrument when taken to the service agency.
3. Always have service done by a McIntosh authorized service agency. If the instrument is modified or damaged as a result of unauthorized repair the service contract will be cancelled. Damage by improper use or mishandling is not covered by the service contract.
4. The service contract is issued to you as the original purchaser. To protect you from misrepresentation this contract cannot be transferred to a second owner.
5. Units in operation outside the United States and Canada are not covered by the McIntosh Factory Service Contract, irrespective of the place of purchase. Nor are units acquired outside the USA and Canada, the purchasers of which should consult with their dealer to ascertain what, if any, service contract or warranty may be available locally.

# Installation

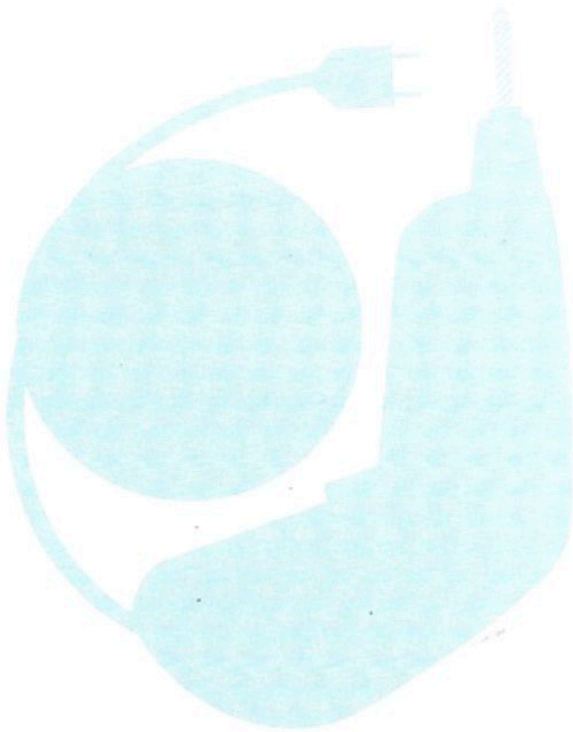

The PANLOC system of installing equipment conveniently and securely is a direct result of McIntosh research. By depressing the two PANLOC buttons on the front panel of the MC 2002, the instrument either can be locked firmly in place or unlocked so that the chassis can be slid forward, giving you easy access to the top panels.

The trouble-free life of an electronic instrument is greatly extended by providing sufficient ventilation to prevent the buildup of high internal temperatures that cause deterioration. Allow enough clearance so that cool air can enter at the bottom of the cabinet

and be vented from the top. With adequate ventilation the instrument can be mounted in any position. The recommended minimum space for installation is 15 inches (38.1 cm) deep, 17 inches (43.2 cm) wide, and 8 inches (20.3 cm) high.

To install the instrument in a McIntosh cabinet, follow the instructions that are enclosed with the cabinet. For any other type of installation follow these instructions:

1. Open the carton and remove the PANLOC brackets, hardware package, and mounting template. Remove the MC 2002 and place it upside down on a smooth surface. Remove the two screws securing the shipping pallet and remove the pallet. Remove the MC 2002 from its plastic bag and unscrew the four plastic feet from the bottom of the chassis. (Note, if the MC 2002 is to be used by itself, not cabinet mounted, leave the four plastic feet on the unit. They are necessary to support the MC 2002 for proper ventilation.)

2. Mark the cabinet panel.

Place the mounting template in the position on the cabinet panel where the instrument is to be installed, and tape it in place. The broken lines that represent the outline of the rectangular cutout also represent the outside dimensions of the chassis. Make sure these lines clear shelves, partitions, or any equipment. With the template in place, first mark the six A and B holes and the four small holes that locate the corners of the cutout. Then, join the four corner markings with pencil lines, using the edge of the template as a straightedge.

3. Drill Holes

Use a drill with a 3/16 inch bit held perpendicular to the panel and drill the six A and B holes. Then, using a drill bit slightly wider than the tip of your saw blade, drill one hole at each of two diagonally opposite corners. The holes should barely touch the inside edge of the penciled outline. **Before taking the next step, make sure that the six A and B holes have been drilled.**

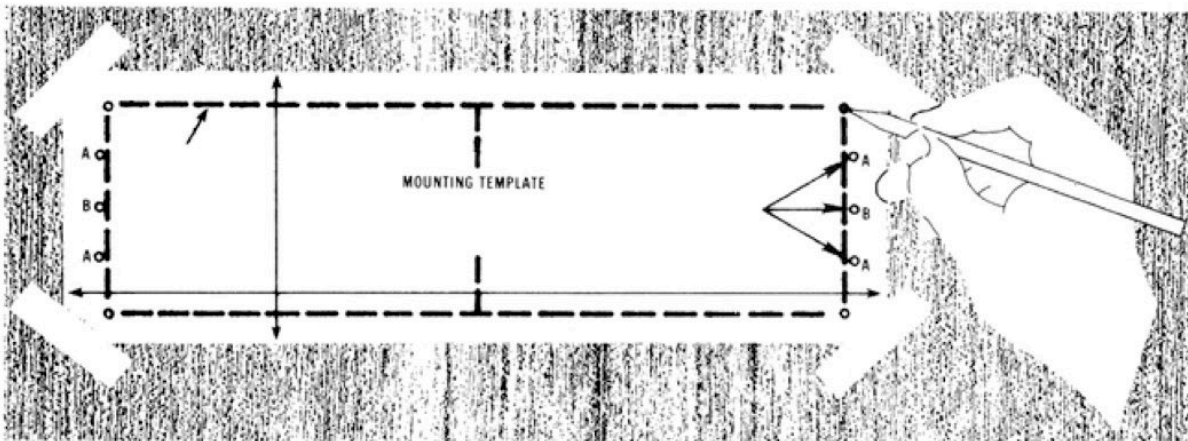



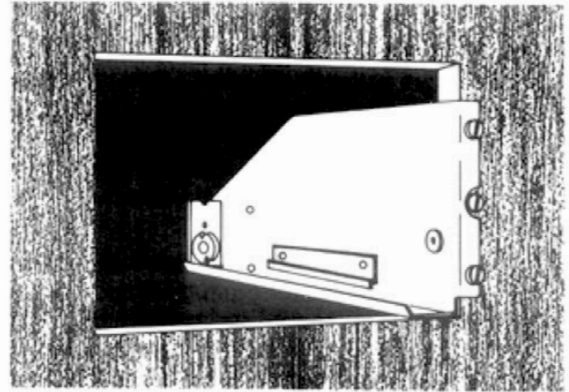
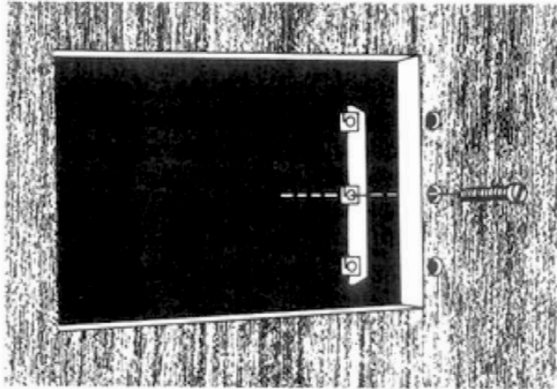

#### 4. Saw the Panel Cutout

Saw carefully on the inside of the penciled lines. First make the two long cuts and then the two short cuts. After the rectangular opening has been cut out, use a file to square the corners and smooth any irregularities in the cut edges.

#### 5. Install the Mounting Strips

In the hardware package you will find two mounting strips, and two sets of machine screws. For panels that are less than 1/2 inch thick, use the 3/4 inch screws; for panels that are more than 1/2 inch thick, use the 1-1/4 inch screws.

Starting at the right-hand side of the panel, insert a screw of the proper length into the center hole in the panel, marked B on the template. On the back of the panel, align a mounting strip with the holes in the panel and tighten the screw until the screwhead is pulled into the wood.

Repeat this procedure to attach the mounting strip to the left side of the panel.

#### 6. Attach the PANLOC Brackets

Using two screws of the proper length in the A holes on each side, attach the PANLOC brackets to the cabinet panel; the short flange is mounted against the front (face) of the cabinet panel. The screws pass through the PANLOC bracket flange, the cabinet panel, and then through the mounting strips previously mounted.

The MC 2002 weighs 50 pounds (22.7 kg). The PANLOC brackets transmit this weight to the cabinet panel. If the panel cannot handle this weight, a cross brace should be added in the cabinet to support the rear of the PANLOC brackets. This brace should be sized and positioned so that it will not block the ventilation holes in the amplifier bottom cover.

#### 7. Install the Instrument

Guide the AC power cord through the panel opening to the back of the cabinet; then, slide the instrument into the opening carefully so that the rails on the bottom of each side of the chassis engage the

tracks on the mounting brackets. Continue to slide the instrument into the cabinet until it is stopped by the adjust position latches. Press the latches inward, this permits the instrument to slide into the cabinet until its front panel is flush with the cabinet panel. Depress the PANLOC buttons at the lower left and right corners of the instrument panel to lock the unit firmly in the cabinet. Depressing the PANLOC buttons again will unlock the instrument so that it can slide forward to the adjust position; if you press inward on the adjust position latches then you can remove the instrument from the cabinet.

# Front Panel Features

## POWER

The power switch turns the MC 2002 on or off. The switch does not control the power outlet on the back panel. If you wish to control the AC power from a preamplifier control center leave the switch in the on position. Be sure the AC cord of the MC 2002 is plugged into the controlled outlets on the rear of the preamplifier control center.

## POWER GUARD INDICATOR LAMPS

POWER GUARD assures that the power amplifier section of the MC 2002 can not be over driven, thus amplifier output clipping is eliminated. Clipping is caused when the amplifier is asked to produce more power output than it can deliver with low distortion. Amplifiers are capable of delivering large quantities of power when they are driven to clipping and can have more than 40% harmonic distortion. The extra energy content of the clipped signal will damage most speakers. A McIntosh advancement helps to protect your speaker from this kind of damage. The MC 2002 has a built in "waveform comparator" that compares the wave shape of the output signal to the input signal. If the non-linearity between the two signals exceeds 0.5% the POWER GUARD circuit operates. Operation is indicated when the amber LEFT or RIGHT POWER GUARD indicators turn on. As long as the amplifier operates without overload the indicator remains off.

## TEMPERATURE INDICATOR LAMP

Sufficient ventilation is required to prevent the build-up of high internal temperatures that can cause deterioration of the MC 2002. In the event that there is not adequate ventilation protection, circuits within the MC 2002 will turn off the overheated channel and will light the red TEMP indicator. When the internal temperature returns to normal the channel will turn on again and the TEMP indicator will turn off. If the TEMP indicator operates, the ventilation should be improved. Shorted speaker leads or an excessively low load impedance on the output of the amplifier can also cause overheating. Check for and correct these conditions should they exist.

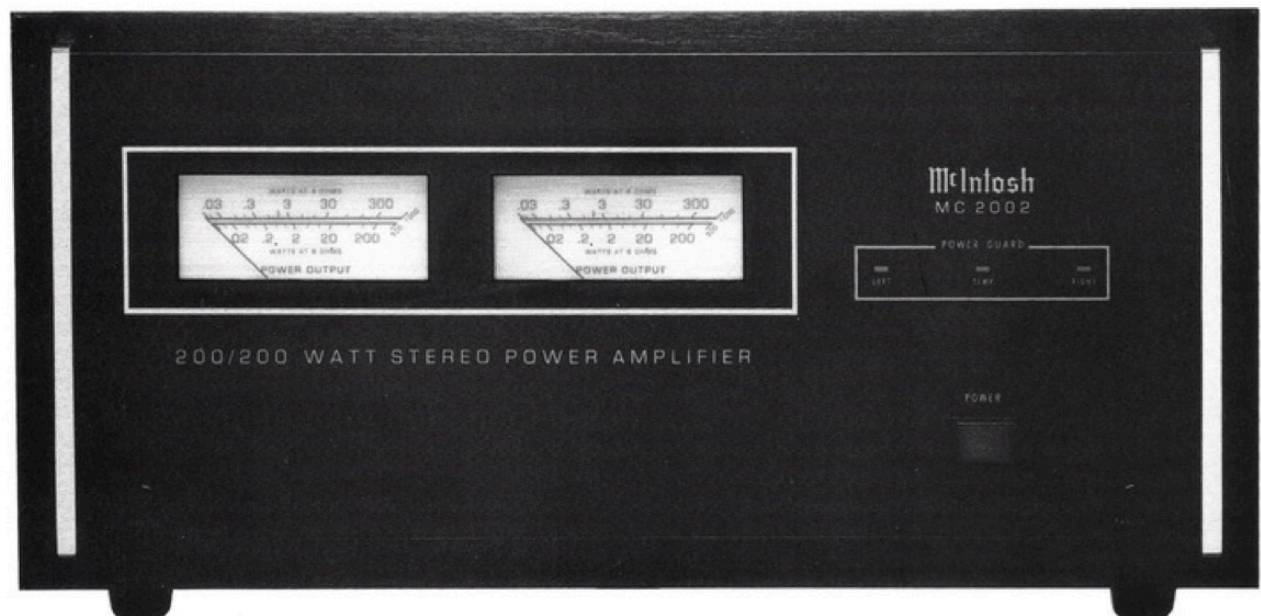



# Rear Panel Information

## LEFT and RIGHT OUTPUT

For stereo operation, output connections for impedances of 4 to 8 ohms are provided on a secure, screw type barrier strip. For monophonic operation proper interconnection provides 8 ohms from the same barrier strip.

## MODE SWITCH

The MC 2002 can be used for stereo or mono (single channel) operation. The MODE switch is used to select the method of operation desired.

## INPUT

In the stereo mode of operation both input jacks accept signal. In the mono mode of operation only the RIGHT/MONO channel input jack accepts signal and the LEFT channel input jack is disconnected.

## INPUT LEVEL

The input sensitivity of the MC 2002 is 1.4 volts or 2.5 V depending on the position of the INPUT LEVEL switch. With indicated voltage applied the amplifier will deliver its rated power output. All McIntosh preamplifiers have been designed to deliver 2.5 volts output with rated input. For the best signal to noise ratio when using McIntosh source equipment, place the INPUT LEVEL switch in the 2.5 V position. If more gain is desired the 1.4 V position may be used. For source equipment other than McIntosh set the switch in the position nearest to the stated output rating of the source equipment.

## AC POWER

The MC 2002 is rated for 120 volts, 50/60 hertz. It uses 0.6 amperes when there is no signal output and up to 15 amperes with both channels delivering rated power. A 15 ampere fuse protects the MC 2002 electrically. The AC power outlet provided for auxiliary equipment is neither fused nor switched.





# How to Connect

## INPUT

### STEREO OR TWIN AMPLIFIER OPERATION

Use shielded cables to connect the signal from the preamplifier or signal source to the power amplifier input. To minimize the possibility of hum the shielded cables should be run parallel to each other or loosely twisted together. Locate the cables away from speaker leads and AC power cords. All connections are made on the back panel of the MC 2002.

For stereo operation, the left output of the preamplifier should be plugged into the LEFT INPUT jack of the power amplifier. The right output of the preamplifier should be plugged into the RIGHT/MONO INPUT jack of the power amplifier.

### MONOPHONIC OR SINGLE CHANNEL OPERATION

A shielded cable from the signal source is plugged into the RIGHT/MONO INPUT jack of the MC 2002 only. The MODE switch on the back panel of the amplifier must be placed in the MONO position. In the MONO position the RIGHT/MONO INPUT jack connects to both amplifiers. The LEFT INPUT is disconnected.

## OUTPUT

Selection of the proper gauge wire to connect the loudspeakers preserves the quality of sound reproduction for which the loudspeakers have been designed. If undersize wire is used, resistance is added to the amplifier/loudspeaker combination which adversely affects the performance. Added resistance causes reduction of damping characteristics, modification of frequency response and reduction in power output.

Use lamp cord or wire with similar type of insulation to connect the speakers to the amplifier. In all cases, the leads to and from the speaker should be twin conductor or twisted together. When using 8 ohm speakers and for the normally short distances of under 30 feet between the amplifier and speaker, No. 18 wire or larger can be used. For distances over 30 feet between the amplifier and speaker use larger diameter wire. Select the correct size wire for the wire length from the chart. It is recommended that the DC resistance of the speaker leads be less than 5% of the speaker impedance. Up to 10% can be tolerated. Resistance of the leads should be computed for the length of wire both to and from the speaker or speakers.



### MAXIMUM WIRE LENGTHS

Wire Gauge	For 4 Ohm Load		For 8 Ohm Load	
	Feet	Meters	Feet	Meters
18	15	4.6	30	9.1
16	25	7.6	50	15.2
14	40	12.2	80	24.4
12	60	18.3	120	36.6
10	100	30.5	200	61.0

Wire lengths above represent the wire resistance equal to 5% of the speaker impedance.

For multiple speaker operation, run separate leads from the amplifier to the speakers.

### CONNECTING LOUDSPEAKERS FOR STEREO

Connect the leads from the left loudspeaker to the Left and Common OUTPUT terminals on the MC 2002. Connect the leads from the right main loudspeaker to the Right and Common terminals.

### CONNECTING ONE LOUDSPEAKER FOR MONO

Connect leads from the loudspeaker to the Left and Right OUTPUT terminals on the MC 2002. Check to be sure the MODE switch is in the MONO position.

In MONO operation neither output terminal (Left or Right) is at ground potential. The output is balanced to ground. Due precaution is required when connecting test instruments since neither terminal can be grounded.

## AC POWER

The amplifier AC power cord is plugged into a 120 volt 50/60 Hz wall outlet, or into an outlet on the preamplifier.

## FUSE

A 15-amp fuse protects the MC 2002 circuits. The fuse does not protect additional equipment connected to the rear panel AC power outlets.

# Stereophonic Connections

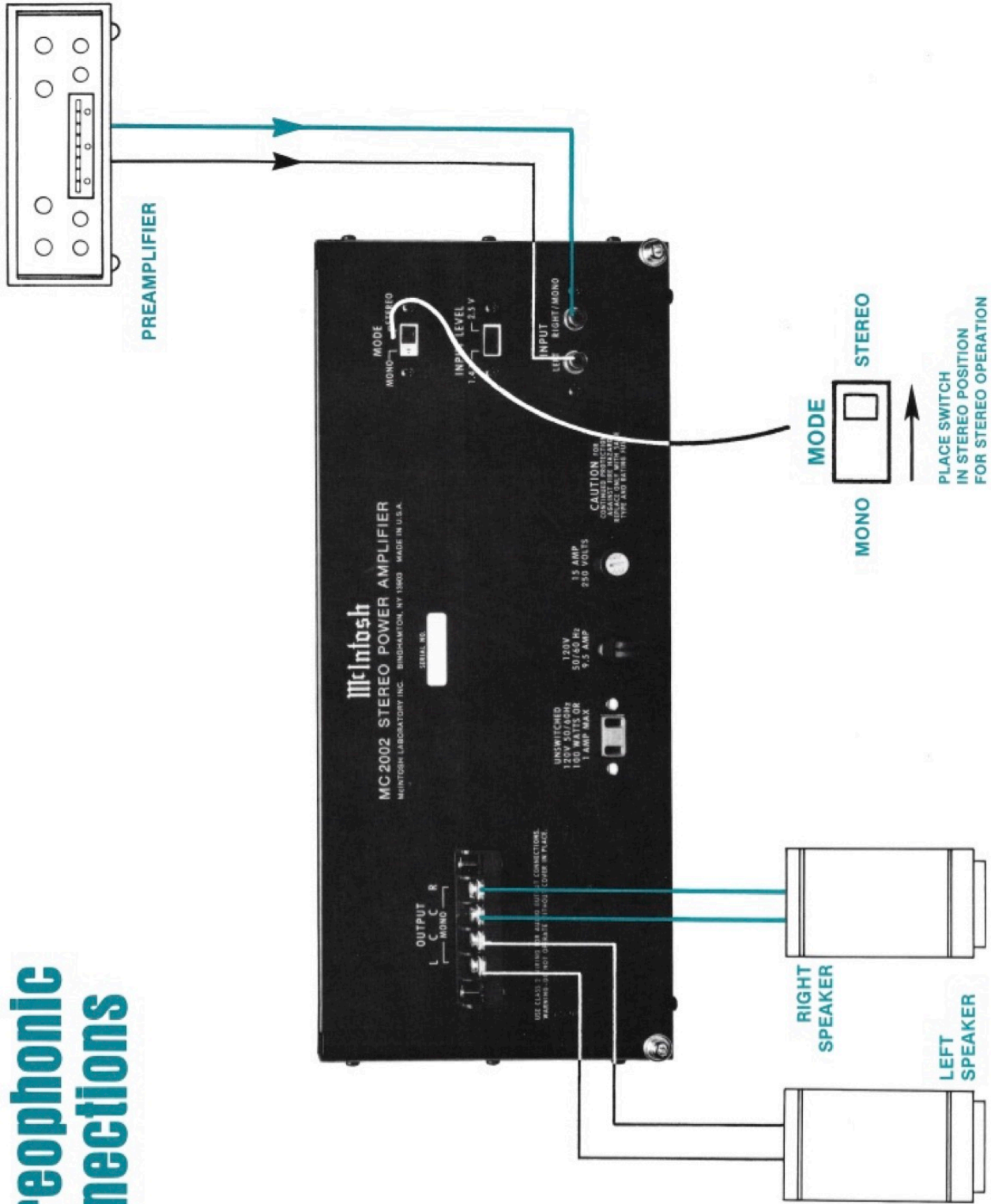



# Monophonic Connections

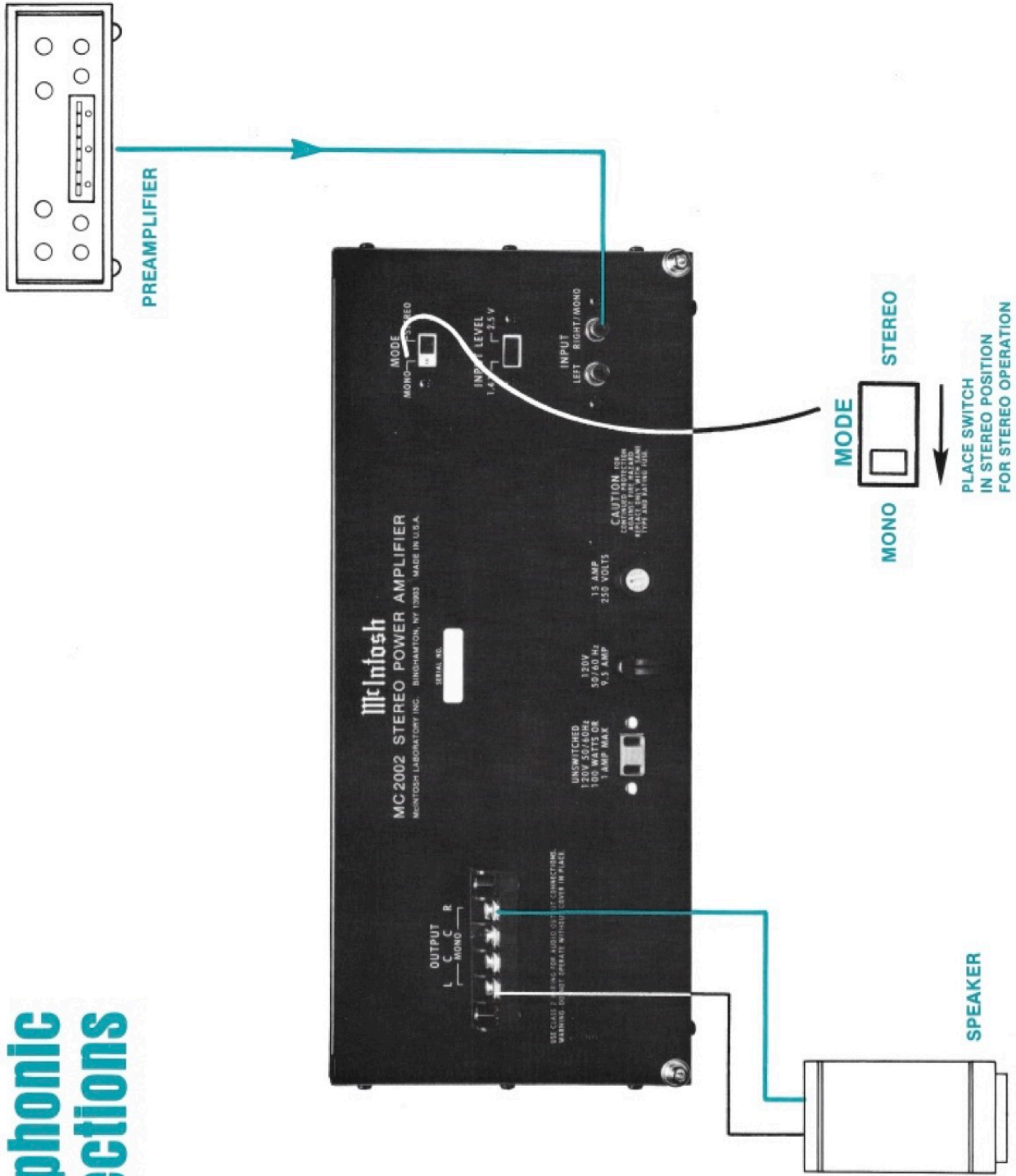

# Technical Description

## TECHNICAL FEATURES

The MC 2002 is a basic stereo power amplifier designed to operate with loudspeakers having a nominal impedance of 4 ohms to 8 ohms. The amplifier is rugged and reliable.

It features a new circuit design that holds harmonic distortion so small that it is far below the amplifier's remarkably low -113 dBA noise floor. Only by using special spectrum analysis measuring techniques is the distortion measurable at all.

The secret to this performance will sound very simple, perhaps, even obviously so, but it is more difficult to carry out than it may seem. The principle used in the design of the MC 2002 was to arrange every stage of voltage or current amplification to have as nearly linear operation as is possible.

This linear operation is accomplished by using several different techniques.

1. Each transistor is selected to have a nearly constant current gain (Beta) over the entire range of currents at which the transistor must operate.

2. The load impedance presented to each amplification stage is made to be as uniform or constant as possible for all signal levels. This requires loading each stage as lightly as possible by its following stage. Resistive or reactive loading is used to reduce the effects of varying input impedance of the next stage.

3. The input impedance of stages is increased and linearized when possible by using emitter degeneration.

4. Resistors and capacitors in the signal path are carefully selected to have exceedingly low voltage coefficients (low change of resistance or reactance with applied voltage). Precision metal film resistors and low dielectric absorption film capacitors are used in all critical circuit locations.

5. Output transistors have matched uniform current gain, high current gain - bandwidth product, low output capacitance, and large active-region safe operating area. These characteristics and the automatic tracking bias system eliminate cross-over distortion, which is often associated with Class B amplification. The distortion graphs show clearly that distortion does not increase at lower power output levels.

The mechanical and electrical design of the MC 2002 is the result of the many years of engineering and manufacturing experience held by the staff at McIntosh. This "know how", the meticulous attention to design and production details, makes the MC

2002 one of the finest products ever produced by McIntosh Laboratory.

## PROTECTION CIRCUITS

Some manufacturers of power amplifiers advertise that their products do not require or use protection circuits and that such circuits compromise performance. McIntosh Laboratory agrees that diligent measures are required to allow unrestricted performance, but we also insist that protection circuits are desirable and necessary to prevent amplifier or loudspeaker damage due to abnormal circumstance and that they actually enhance performance. The MC 2002 incorporates seven protection circuits to enhance its performance, assure its reliability and to protect loudspeakers driven by the MC 2002.

### 1. Power Guard

Power Guard, a unique feature of McIntosh amplifiers, assures that each channel of the MC 2002 will deliver full power free of clipping distortion. Clipping is caused when an amplifier is asked to produce more clean power output than its design characteristics can deliver with low distortion. Amplifiers that are overdriven are capable of delivering large quantities of power when they are clipping but they have more than 40% harmonic distortion. In this mode, the sound is grossly distorted and the extra energy content of the clipped signal will damage most loudspeakers. The McIntosh Power Guard circuit protects your ears and your speakers from this kind of damage.

The MC 2002 has a built in "waveform comparator" that compares the wave shape of the amplifier output signal to the input signal. If the distortion content between the two signals exceeds 0.5%, the Power Guard circuit operates automatically to prevent the normal increase to 40% or more distortion. Operation is indicated when the amber left or right Power Guard lamps turn on. At the same time, an electronically controlled attenuator reduces the gain of the amplifier just enough to prevent clipping. As long as the amplifier operates without overload, the indicators remain off. Power Guard assures that you get the maximum undistorted power output available from the amplifier, and it makes sure that you hear the full rated power of the amplifier at low distortion.

### 2. Sentry Monitor

All power transistors have limits for the maximum amount of electrical current they can handle. The MC 2002 output transistors and power supply have been designed to allow very high current flow into properly matched load impedances. If, however, a short circuit or very low value of load impedance is



applied to the output of the MC 2002, destructive current levels could be reached if it was not controlled by the Sentry Monitor circuit. This circuit senses the dynamic operating condition of the amplifier output stage and controls the current flow confining it to non-destructive limits. Sentry Monitor does not limit the power output available from the amplifier.

### 3. Thermal Shut-down

All power transistors have limits for the maximum amount of heat they can tolerate. The MC 2002 uses a highly efficient amplifying circuit which produces relatively little heat for the output power produced. The amplifier has four oversized heat sinks to dissipate transistor generated heat. Under normal conditions, the transistors will operate well below their safe temperature limits. If ventilation is restricted by improper mounting or if amplifier efficiency is destroyed by operating it into a short circuit or a very low load impedance, extra heat will be produced. Thermal sensors within the MC 2002 will shut down one or both channels if temperatures become excessive. This prevents the transistors from producing life reducing heat. A red TEMP indicator lamp will illuminate to show this action. When the temperature reduces to a safe value, the amplifier operation will return to normal. If the TEMP indicator operates, the cause for the excessive heating should be investigated and corrected. Look for restricted ventilation or shorted or improperly matched outputs.

### 4. Turn-on Delay

The MC 2002 has a turn-on delay circuit that delays amplifier operation for about 2 seconds after power turn on. This prevents pops or thumps from causing annoying noises or from damaging your loudspeakers.

### 5. Direct Current Failure Protection

All power amplifiers, which do not use output transformers to bypass DC (direct current), can destroy loudspeakers should there be a failure within the amplifier. Safety circuits are necessary to protect loudspeakers. The MC 2002 has a DC detecting circuit connected to the output of each channel. Should there be DC present, this circuit clamps the power supply to zero voltage to prevent damage to loudspeakers. This clamp action will blow the MC 2002 fuse. The circuit returns to normal when the cause for DC is corrected and the fuse is replaced.

### 6. Power Line Transient Surge Protection

High voltage surges are sometimes present on 120 volt power lines due to switching of heavy loads like air conditioners or furnace motors. These surges can destroy critical electronic circuits. The MC 2002 power supply circuit is arranged to clamp momentary surges to safe levels.

### 7. Peak Responding Power Output Meters

Two power output meters allow the power output of the MC 2002 to be monitored. These meters use

full wave detection and respond to the positive and negative peaks of the audio waveform.

While the meters do not actually provide amplifier or loudspeaker protection, they do allow monitoring the power produced by the amplifier. This knowledge can be useful to prevent overdriving loudspeaker systems or to provide a power indication of the actual loudness of program material.

### CIRCUIT OPERATION

Each amplifier channel of the MC 2002 uses two stages of voltage amplification followed by three stages of current amplification. The input signal feeds one input of a differential amplifier stage. Negative feedback from the amplifier output is applied to the other input. The differential amplifier outputs connect to current mirrors and feed a positive drive cascode voltage amplifier. Negative drive is provided by an active current source. The cascode voltage amplifier output feeds complementary Darlington driver transistors. These supply the signal to 8 complementary connected output transistors. Ancillary components for Power Guard, Sentry Monitor, Power Output Meters and other protection circuits interconnect with the amplifier circuits. The power supply uses a massive power transformer, full wave bridge rectifiers and large filter capacitors having 77 joules of energy storage. Four large heat sinks provide cooling for the 16 output power transistors. The MC 2002 chassis is arranged for vertical airflow for convection cooling.



# Performance Limits

Performance limits are the maximum deviation from perfection permitted for a McIntosh instrument. We promise you that when you purchase a new MC 2002 from a McIntosh franchised dealer, it will be capable of or can be made capable of performance at or exceeding these limits or you can return the unit and get your money back. McIntosh is the only manufacturer that makes this statement.

## PERFORMANCE

McIntosh audio power ratings are in accordance with the Federal Trade Commission Regulation of November 4, 1974 concerning power output claims for amplifiers used in home entertainment products.

## POWER OUTPUT

### STEREO:

- 200 watts into 8 ohm loads or
- 300 watts into 4 ohm loads is the minimum sine wave continuous average power output per channel for 20 Hz to 20,000 Hz with both channels operating, which is:
- 40.0 volts RMS across 8 ohms or
- 34.6 volts RMS across 4 ohms.

### MONO (Bridged):

- 600 watts into an 8 ohm load, is the minimum sine wave continuous average power output from 20 Hz to 20,000 Hz, which is
- 69.3 volts RMS across 8 ohms.

## OUTPUT LOAD IMPEDANCE

- STEREO: 4 ohms to 8 ohms.
- MONO: 8 ohms obtained by connecting across the output terminals of both channels.

## RATED POWER BAND

- 20 Hz to 20 kHz

## TOTAL HARMONIC DISTORTION

### STEREO:

0.01% maximum harmonic distortion at any power level from 250 milliwatts to rated power per channel from 20 Hz to 20,000 Hz, both channels operating.

### MONO:

0.01% maximum harmonic distortion at any power level from 250 milliwatts to rated power from 20 Hz to 20,000 Hz.

## INTERMODULATION DISTORTION

### STEREO:

0.01% maximum if instantaneous peak power output does not exceed twice the output rating or less per channel with both channels operating for any combination of frequencies, 20 Hz to 20,000 Hz.

### MONO:

0.01% maximum if instantaneous peak power output does not exceed twice the output rating or less for any combination of frequencies, 20 Hz to 20,000 Hz.

## FREQUENCY RESPONSE (at one watt output)

- + 0, - 0.25dB from 20 Hz to 20,000 Hz
- + 0, - 3.0dB from 10 Hz to 100,000 Hz

## HUM AND NOISE

- 100dB below rated output
- 90dB IHF

## RATINGS

### IHF DYNAMIC HEADROOM:

- 2.1dB at 4 ohm load
- 1.7dB at 8 ohm load

### DAMPING FACTOR

- Greater than 100

### INPUT IMPEDANCE

- 20,000 ohms

### INPUT SENSITIVITY

- Switchable for either 1.4 volt or 2.5 volt

### POWER REQUIREMENT

- 120 Volts, 50/60 Hz, 0.6 to 15 amperes

## MECHANICAL INFORMATION

**SIZE:** Front Panel measures 16 3/16 inches wide (41.1 cm) by 7 1/8 inches high (18.1 cm). Chassis measures 14 3/4 inches wide (37.5 cm) by 6 1/2 inches high (16.5 cm) by 14 1/2 inches deep (36.8 cm), including connectors. Clearance required in front of the mounting panel is 3/4 inches (1.9 cm).

**FINISH:** Front panel is anodized gold and black with special gold/teal nomenclature illumination. Chassis is black.

**WEIGHT:** 50 pounds (22.7 kg) net. 64 pounds (29 kg) in shipping carton



# Performance Charts

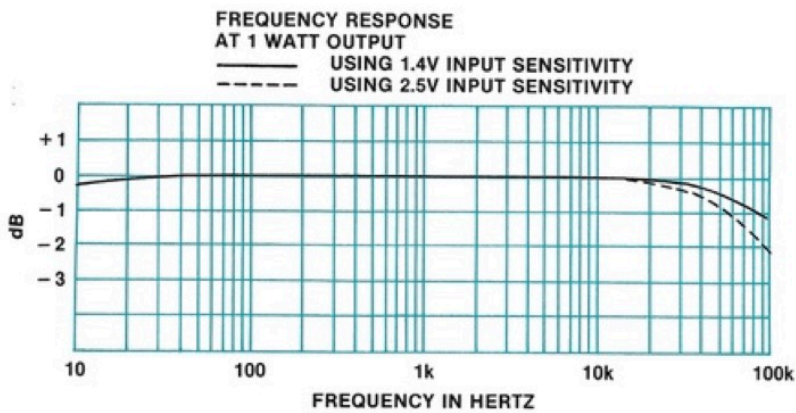
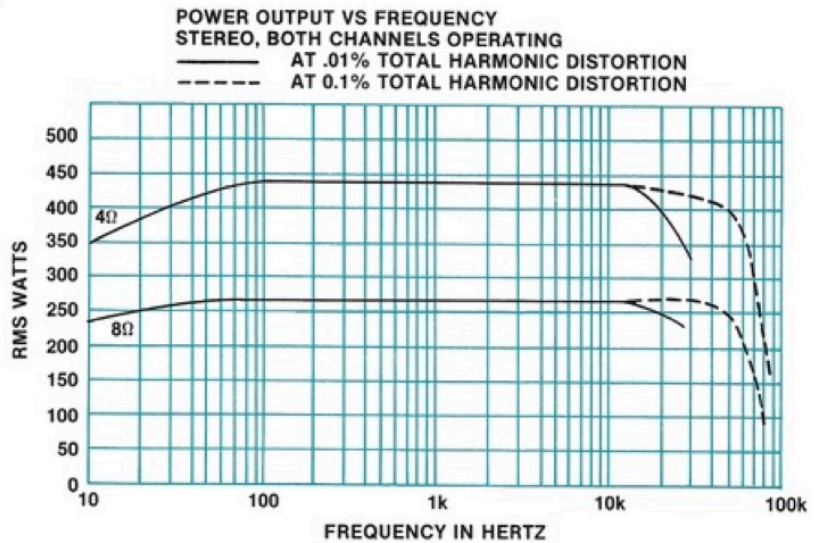
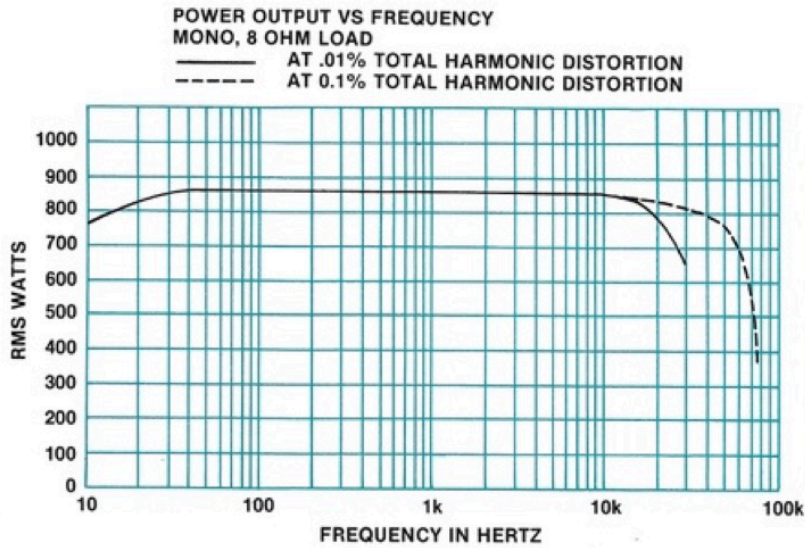

**HARMONIC DISTORTION\*  
VS FREQUENCY  
AT RATED OUTPUT**  
 ——— 8Ω LOAD, 200 WATTS  
 - - - 4Ω LOAD, 300 WATTS

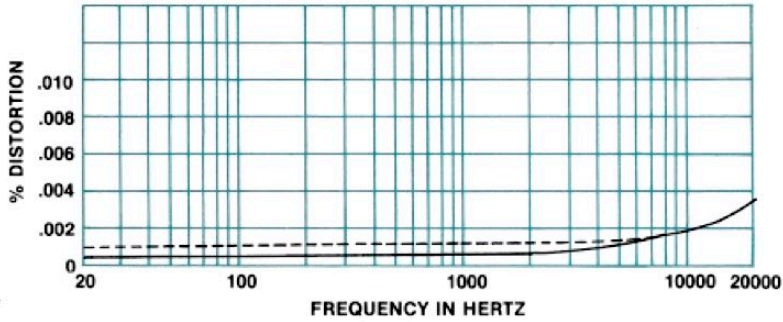

**HARMONIC DISTORTION\*  
VS POWER OUTPUT  
8 OHM LOAD**  
 - - - 20 Hz  
 ——— 1 kHz  
 - - - 20 kHz

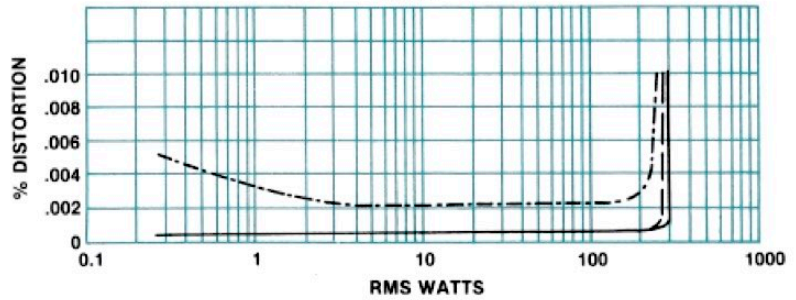

**HARMONIC DISTORTION\*  
VS POWER OUTPUT  
4 OHM LOAD**  
 - - - 20 Hz  
 ——— 1 kHz  
 - - - 20 kHz

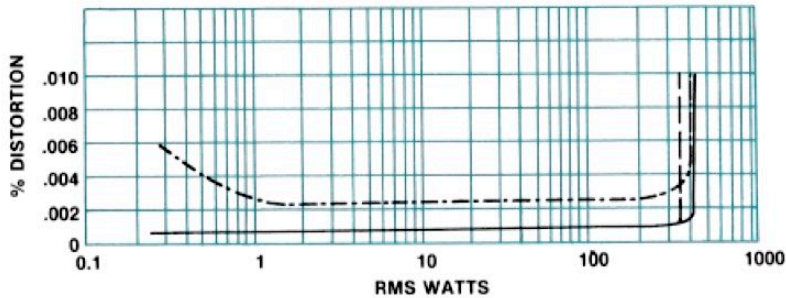

**\* NOTE**

Many of the harmonic distortion measurements presented here are below the noise level at the amplifier output. These measurements were made using a Hewlett Packard HP 339 Distortion Analyzer followed by a Tektronix 5L4N Spectrum Analyzer. All significant harmonics to 140 kHz are included.



# Block Diagram

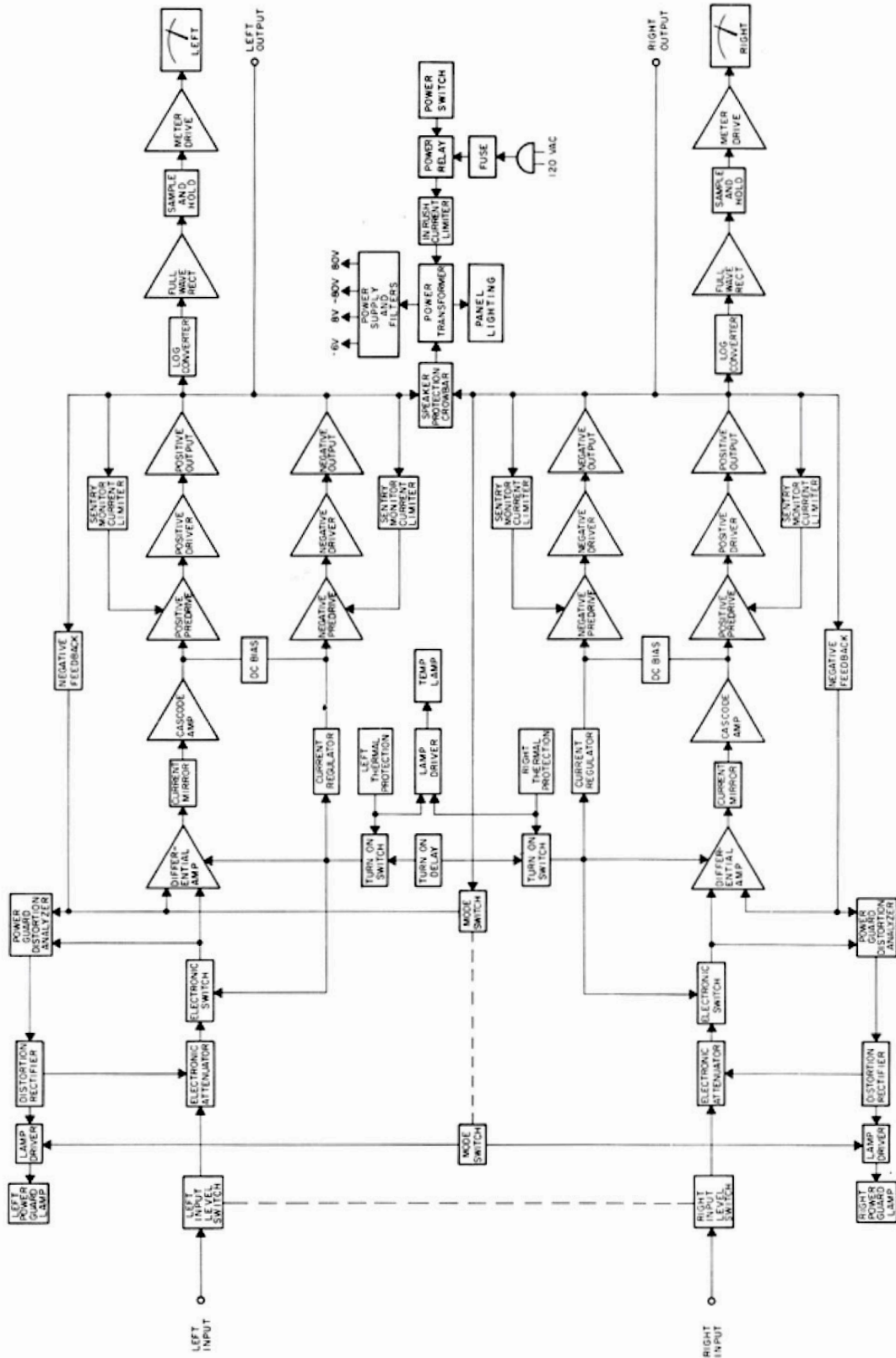

McINTOSH MC 2002 STEREO POWER AMPLIFIER

**McIntosh®**

**McINTOSH LABORATORY INC.**  
**2 CHAMBERS ST., BINGHAMTON, NY 13903-2699**  
**607-723-3512**

The continuous improvement of its products is the policy of  
McIntosh Laboratory Incorporated who reserve the right  
to improve design without notice.  
Printed in U.S.A.

039639