

LS340 Loudspeaker System



LS340

WARNING - TO REDUCE RISK OF FIRE OR ELECTRICAL SHOCK, DO NOT EXPOSE THIS EQUIPMENT TO RAIN OR MOISTURE.

NO USER-SERVICEABLE PARTS INSIDE. REFER SERVICING TO QUALIFIED PERSONNEL.

IMPORTANT SAFETY INSTRUCTIONS!

PLEASE READ THEM BEFORE OPERATING THIS EQUIPMENT.

General:

1. Read these instructions.
2. Keep these instructions.
3. Heed all warnings.
4. Follow all instructions.
5. **Warning: To reduce risk of fire or electrical shock, do not expose this equipment to rain or moisture. This unit is capable of producing high sound pressure levels. Continued exposure to high sound pressure levels can cause permanent hearing impairment or loss. User caution is advised and ear protection is recommended when playing at high volumes.**
6. Only use attachments/accessories specified by the manufacturer.

Installation:

7. Install in accordance with the manufacturer's instructions.
8. Do not install near any heat sources such as radiators, heat registers, stoves, or other equipment (including amplifiers) that produce heat.
9. Do not use this equipment near water.
10. Do not expose this equipment to dripping or splashing and ensure that no objects filled with liquids, such as vases, are placed on the equipment.
11. Use only with the cart, stand, tripod, bracket, or table specified by the manufacturer, or sold with the equipment. When a cart is used, use caution when moving the cart/equipment combination to avoid injury from tip-over.



Care of Equipment:

12. Clean only with a dry cloth.
13. Do not permit objects or liquids of any kind to be pushed, spilled and/or fall into the equipment through enclosure openings.

Repair of Equipment:

14. Refer all servicing to qualified service personnel. Servicing is required when the equipment has been damaged in any way, liquid has been spilled or objects have fallen into the equipment, the equipment has been exposed to rain or moisture, does not operate normally, or has been dropped.
15. Do not attempt to service beyond that described in the operating instructions. All other service should be referred to qualified service personnel.
16. When replacement parts are required, be sure the service technician has used replacement parts specified by McIntosh or have the same characteristics as the original part. Unauthorized substitutions may result in fire, electric shock, or other hazards.
17. Upon completion of any service or repairs to this product, ask the service technician to perform safety checks to determine that the product is in proper operating condition.

Thank You

Your decision to own this McIntosh LS340 Loudspeaker System ranks you at the very top among discriminating music listeners. You now have “The Best.” The McIntosh dedication to “Quality,” is assurance that you will receive many years of musical enjoyment from this unit.

Please take a short time to read the information in this manual. We want you to be as familiar as possible with all the features and functions of your new McIntosh.

Please Take A Moment

The serial number, purchase date and McIntosh dealer name are important to you for possible insurance claim or future service. The spaces below have been provided for you to record that information:

Serial Number: _____

Purchase Date: _____

Dealer Name: _____

Technical Assistance

If at any time you have questions about your McIntosh product, contact your McIntosh dealer who is familiar with your McIntosh equipment and any other brands that may be part of your system. If you or your dealer wish additional help concerning a suspected problem, you can receive technical assistance for all McIntosh products at:

McIntosh Laboratory, Inc.
2 Chambers Street
Binghamton, New York 13903
Phone: 607-723-1545
Fax: 607-723-3636

Customer Service

If it is determined that your McIntosh product is in need of repair, you can return it to your dealer. You can also return it to the McIntosh Laboratory Service Department. For assistance on factory repair return procedure, contact the McIntosh Service Department at:

McIntosh Laboratory, Inc.
2 Chambers Street
Binghamton, New York 13903
Phone: 607-723-3515
Fax: 607-723-1917

Table of Contents

Safety Instructions	2
Thank You and Please Take a Moment	3
Technical Assistance and Customer Service	3
Table of Contents and General Notes	3
Introduction	4
Performance Features	4
Dimensions	5 - 6
Installation	7
How to Connect	8
Front and Rear Views	9
Specifications	10
Packing Instruction	11

General Notes

- 1. It is very important that loudspeaker cables of adequate size be used in your music system, to ensure that there will be no power loss or heating. Cable size is specified in Gauge numbers or AWG, (American Wire Gauge). The smaller the Gauge number, the larger the wire size:
If your loudspeaker cables are 25 feet (7.62m) or less, use at least 18 Gauge (AWG) wire size or larger.
If your loudspeaker cables are 50 feet (38.1m) or less, use at least 16 Gauge (AWG) wire size or larger.
If your loudspeaker cables are 100 feet (76.2m) or less, use at least 14 Gauge (AWG) wire size or larger.
The Loudspeaker Connection Terminals can accept up to 12 Gauge (AWG) wire.*
- 2. For additional connection information, refer to the owner's manual(s) for any component(s) connected to the LS340 Loudspeaker.*
- 3. The LS340 has built-in speaker protection in the form of three automatic resetting solid-state devices as part of the crossover network. One protects the tweeter, one the midrange and the other the woofers. The characteristics of this protection are that a certain amount of overdrive is allowed but extended periods of overdrive will trigger protection. If an obvious lack of high or low frequencies is noticed, the Loudspeaker Protection Device may have activated. Sound output from the Loudspeaker Element affected will be reduced when the protection is triggered. The protection devices will automatically reset when the volume control is reduced significantly and kept low until the output of the affected Loudspeaker Element returns to normal.*

Introduction

The McIntosh LS340 Loudspeaker System is designed for Home Theater and Music Reproduction. It is a three-way system with two 8 inch LD/HP¹ woofers, one 6-1/2 inch LD/HP midrange and one 1 inch dome tweeter. The LS340 is designed to work as a Left or Right (Main) Loudspeaker in a Music System, or as a Main or Surround Loudspeaker in a Home Theater System.

The LS340 Loudspeaker performance is equivalent to the quality of McIntosh's legendary line of Amplifiers, Preamplifiers, Signal Processors and Signal Sources, without imparting distortion or coloration of its own. It also complements the capabilities and the remarkably low distortion of McIntosh Power Amplifiers.

Many of today's loudspeakers are designed only for Home Theater applications. Not so with the LS340. It is also designed for the accurate reproduction of music. Motion picture sound effects, explosions, screams, and vehicle crashes require a wide dynamic range and high sound levels. These sounds are such that a speaker system having moderate distortion would reproduce them with little audible difference. This is not true with the reproduction of music. Music is by nature and definition harmonious. To reproduce it accurately, all forms of distortion, both harmonic and intermodulation, must be kept to a minimum. This has been the result of the design of the new McIntosh LS340 Loudspeaker System. Each loudspeaker element and crossover component has been carefully designed for durability, efficiency, and above all, low distortion. The McIntosh LS340 Loudspeaker System will reproduce music accurately and function as an excellent Home Theater Loudspeaker.

Performance Features

● Gold Plated Input Connectors

The LS340 input connectors are gold plated for superior corrosion resistance and high electrical conductivity.

● Acoustic Edge-Hole Elimination

An "edge-hole" is a severe dip in the high frequency response of a speaker system, caused by the relative distance of the dome tweeter to the edge of the speaker cabinet. If the distance to the edge of the cabinet is the same on both sides of the dome tweeter, cancellation of the sound occurs at a specific frequency. McIntosh guards against this phenomenon with a special tweeter mounting that eliminates the "edge-hole" effect. A specially designed tweeter bezel and perforated grille, mask the tweeter mounting to maintain a symmetrical appearance.

● Patented LD/HP Technology

The McIntosh Low Frequency and Midrange Loudspeaker Elements feature the patented LD/HP motor structure. This design, when compared to conventional Loudspeaker Elements, reduces distortion significantly. It also increases power handling and efficiency.

● Shielded Magnetic Field

The LS340 may be used in Home Theater Installations near a television receiver or monitor without causing the television image to degrade. McIntosh has designed special shielding around the magnetic structure of the LS340 Loudspeaker Elements to prevent interference.

● High Power Handling

The Loudspeaker Elements and crossover components of the LS340 are all chosen for use with powerful amplifiers up to 350 watts.

● High Efficiency

The Loudspeaker Elements used in the LS340 Loudspeaker System have also been designed for high efficiency. As a result any McIntosh Power Amplifier, even our smallest, will provide satisfying room filling sound.

● Automatic Overload Protection

The LS340 has built-in Loudspeaker Element Protection in the form of three automatic resetting solid-state devices as a part of the crossover network.

● Flared Acoustic Bass Port

The Acoustic Bass Port in the LS340 has flared front and rear openings to eliminate air movement noise.

¹LD/HP Pat. No. 5,151,943

LS340 Dimensions

The following dimensions can assist in determining the best location for your LS340 Loudspeaker System. There is additional information on the next page pertaining to installing the LS340 into cabinets.

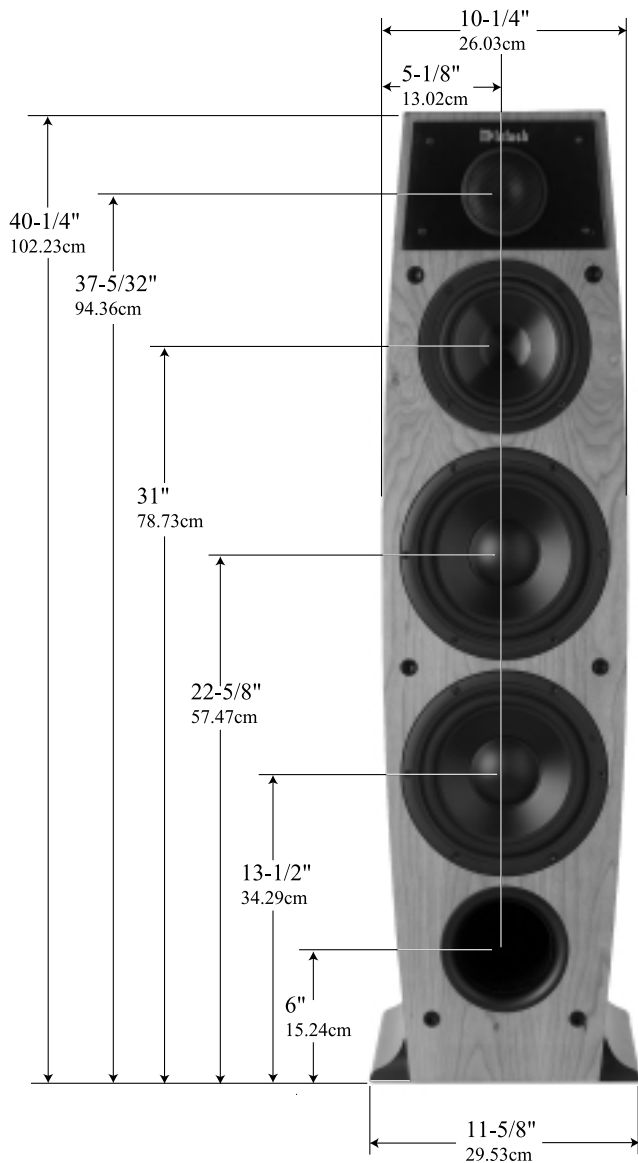

Front View of LS340 with Grille Removed

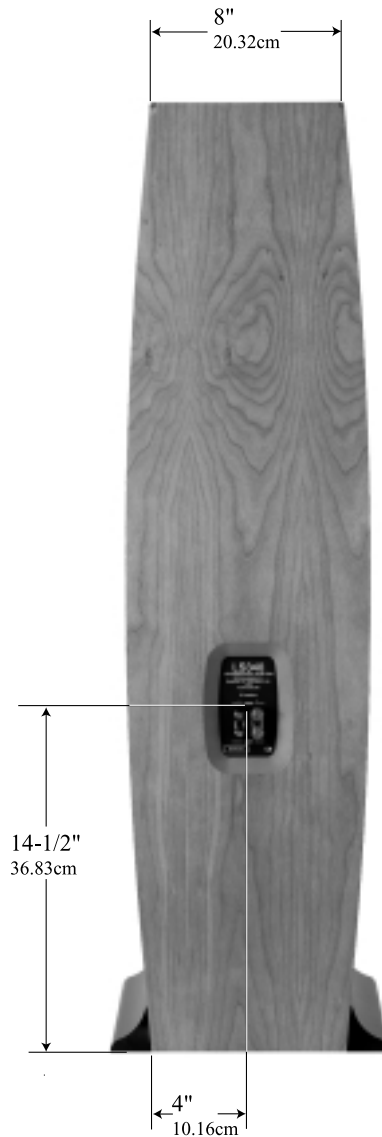

Rear View of LS340

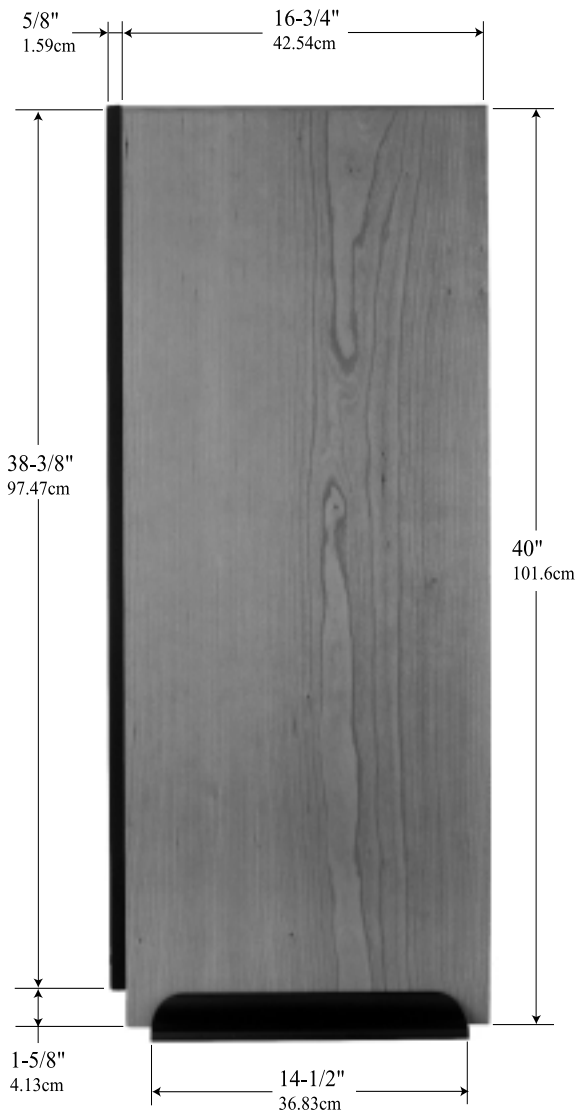

Side View of LS340 with Grille

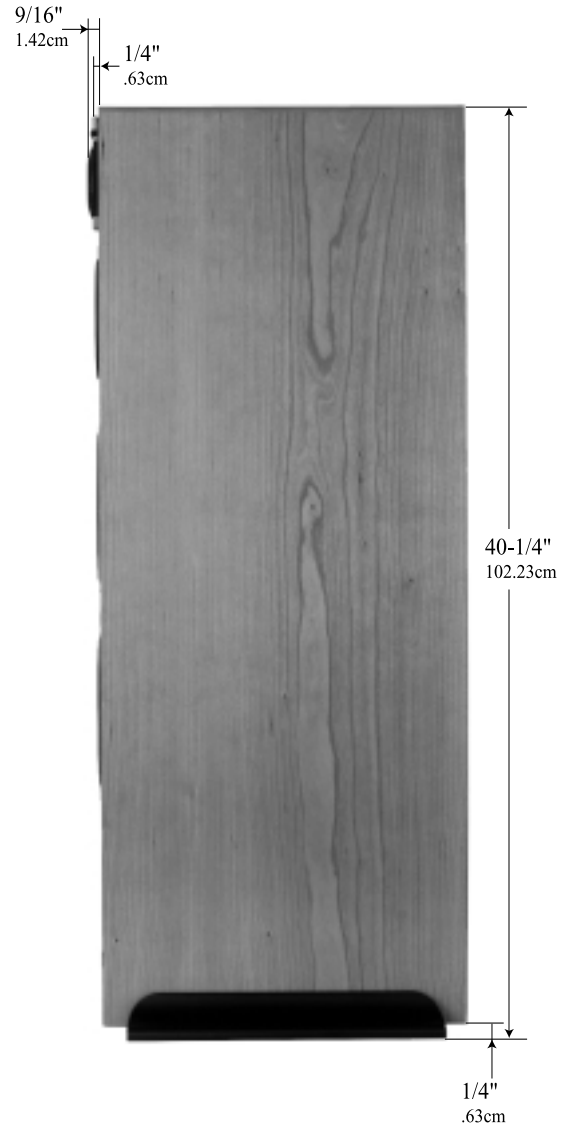

Side View of LS340 with Grille Removed

Installation

Optional Feet

Two sets of optional feet (four Tiptoes and four Glides) are supplied with the LS340 Loudspeaker System. To prevent crushing carpet use the Tiptoe spikes; to protect non-carpeted flooring use the chrome Glides. Both the Glides and Tiptoes have a threaded shaft and locking nut that screw into the tapped holes in the bottom of the LS340's base rails. The feet can be independently adjusted to compensate for uneven flooring or to aim the loudspeakers upward or downward.



Locating your Loudspeakers

Loudspeaker placement in a room can greatly affect performance. The LS340 is designed to work as a Left or Right (Main) Loudspeaker in a Music System, or as a Main or Surround Loudspeaker in a Home Theater System.

The optimal method for selecting speaker locations includes the use of a real time spectrum analyzer operated by an experienced system installer. An uncompromising installation would take into consideration the floor, wall and ceiling coverings, the type and placement of furniture and can even include the architectural design of the room and its construction materials.

Locating Loudspeakers for use in Home Theater

In a Home Theater application, the placement of Left and Right Front Loudspeakers can be limited by such considerations as the size and location of the video monitor. The locating suggestions in the "for use in a Music System" section below can still be helpful. Side Surround

Loudspeakers work best located to either side of and above the listening position, the same distance from the monitor. Back Surround Loudspeakers work best on the back wall. Refer to figure 1.

Locating Loudspeakers for use in a Music System

When used as Left and Right Speakers, the distance between the two loudspeakers should not exceed the distance between the listener and either loudspeaker. If the speakers are too far apart relative to the listener, some imaging can be lost. To assure the sound from the left and right speakers arrive at the same time, the distance from each loudspeaker to the listener should be as close to the same as possible. Refer to figure 2. The LS340 Tweeter should be level with the listeners' ears and adjustment of the height of the feet to angle the loudspeaker up or down is often the way to achieve this.

Placement near a wall, corner, floor, ceiling or any intersecting surfaces will reinforce some bass frequencies. Which bass frequencies are boosted by placement in a particular location is dependant on the dimensions of the room. Test the various loudspeaker locations by playing music with continuous bass, setting up the speakers and listening to them from the main listening spot. Move the loudspeakers to an alternate location and repeat the listening, paying attention to how the bass qualities and response levels change. Do not assume the loudest bass is best; rather listen for booming (a lack of articulation), as well as a balance over the whole spectrum, to assure the bass will not drown out the other parts of the music.

Experiment with various loudspeaker positions until the locations that sound best are found.

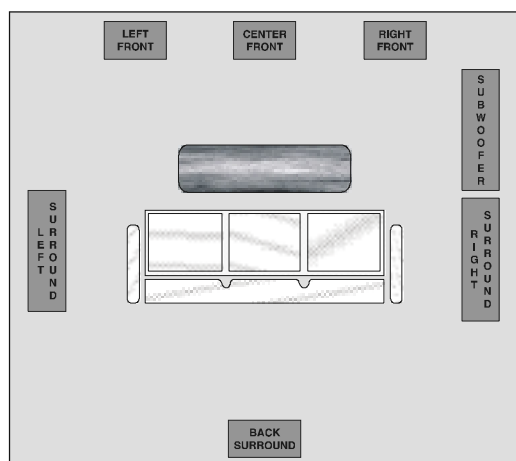

Figure 1

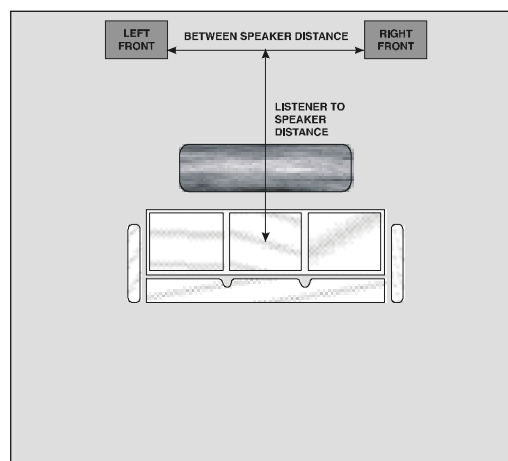

Figure 2

How to Connect

The McIntosh LS340 Loudspeaker System utilizes binding posts for speaker wire connections. Refer to figure 3.

1. Connect a loudspeaker cable from the black (negative \ominus) loudspeaker binding post to the negative or common output terminal of one channel of the amplifier.
2. Connect a loudspeaker cable from the red (positive \oplus) loudspeaker binding post to the positive or 4 ohm output terminal of the same channel of the amplifier.
3. Tighten all of the loudspeaker and amplifier binding posts.

How to Connect to Two Stereo Amplifiers for a Bi-Amplified Configuration

The McIntosh LS340 Loudspeaker System utilizes two pairs of binding posts for bi-amplified speaker wire connections. Refer to figure 3.

Bi-amplification allows the use of multiple smaller amplifiers connected to one loudspeaker, which increases the acoustical output.

Note: Output levels of the two amplifiers connected to the HIGH and LOW Loudspeaker Input Terminals must be adjusted to achieve a proper balance between the high and low frequencies reproduced. This adjustment is best achieved through the use of audio test equipment operated by a qualified installer.

1. Remove the gold interconnecting straps from the two pairs of binding posts on the speakers.
2. Connect a loudspeaker cable from the upper (HIGH), black (negative \ominus) binding post of the right loudspeaker to the negative or common output terminal of the right channel on the amplifier to be used for high and mid-range frequencies.
3. Connect a loudspeaker cable from the upper (HIGH), red (positive \oplus) binding post of the right loudspeaker to the positive or 4 ohm output terminal of the right channel of the amplifier to be used for high and mid-range frequencies.
4. Repeat steps 1, 2 and 3 for the left channel speaker and amplifier to be used for high and mid-range frequencies.
5. Connect a loudspeaker cable from the lower (LOW), black (negative \ominus) binding post of the right loudspeaker to the negative or common output terminal of the right channel on the amplifier to be used for low frequencies.
6. Connect a loudspeaker cable from the lower (LOW), red (positive \oplus) binding post of the right loudspeaker to the positive or 4 ohm output terminal of the right channel of the amplifier to be used for low frequencies.
7. Repeat steps 5 and 6 for the left channel speaker and amplifier to be used for low frequencies.

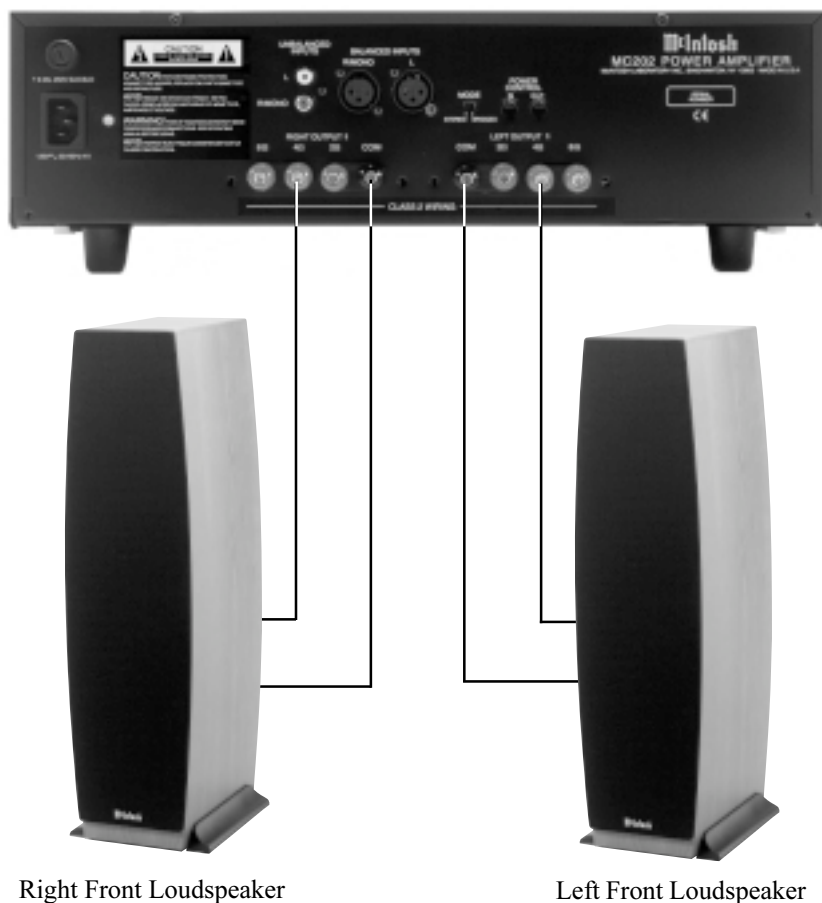

Speaker Connections



Figure 3

- +

To Amplifier Terminals

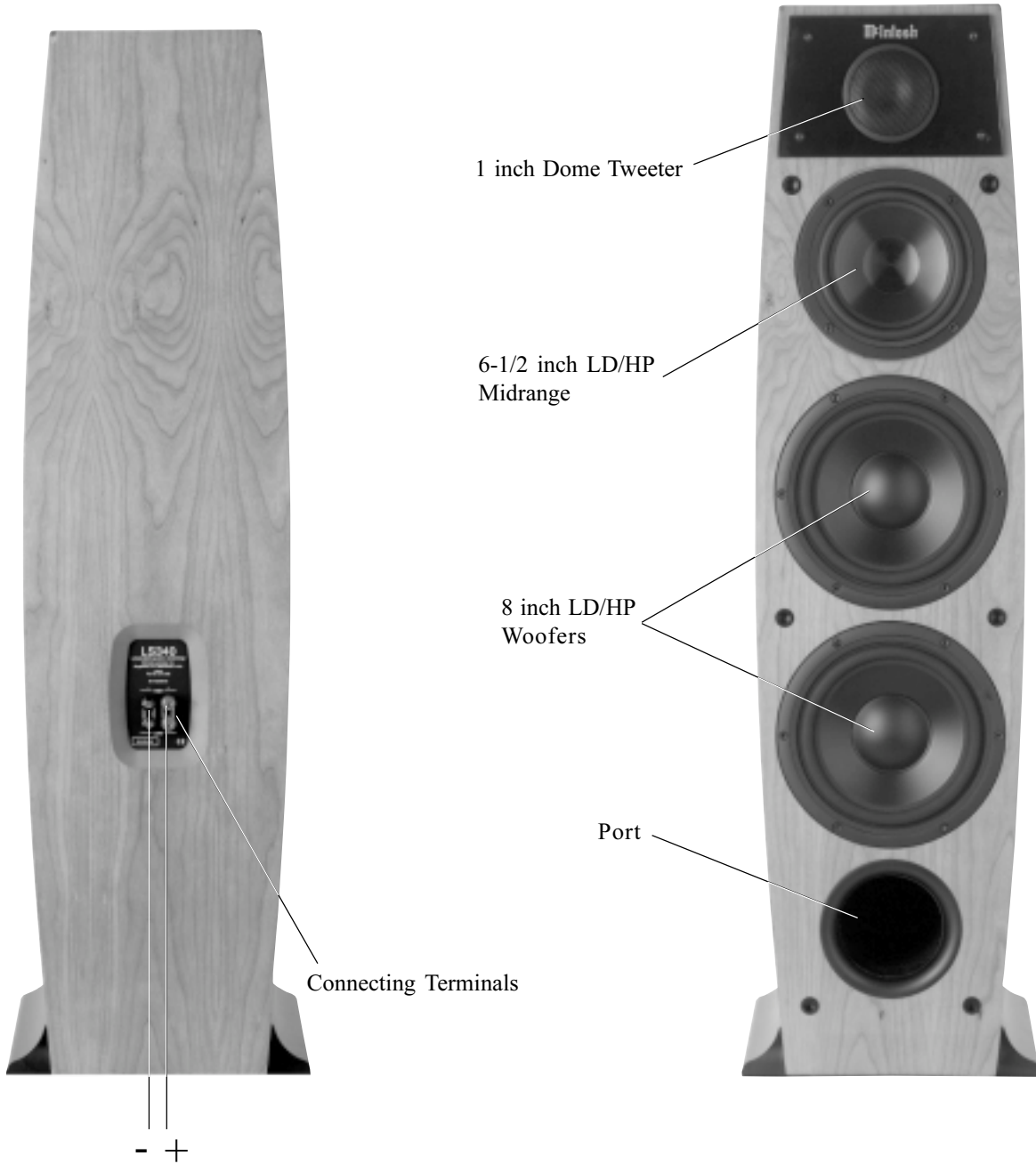

Specifications

Driver Complement

Two 8 inch Woofers
6-1/2 inch Midrange
1 inch Dome Tweeter

Impedance

4 ohms Nominal

Frequency Response

48Hz - 20kHz \pm 2dB (Anechoic Response)

Sensitivity

87dB (2.8V/1m)

Crossover Frequencies

1.5kHz
250Hz

Power Handling

350 Watts Maximum

Dimensions

40-1/4 inches (102.23cm) Height, 10-1/4 inches (26.03cm)
Width, 17-3/8 inches (44.13cm) Depth (including Grill)

Standard Finish

Black Ash, Natural Cherry, Red Cherry

Premium Finish

Rosewood Gloss, Piano Black

Weight (each)

89.5 pounds (40.6kg) net, 110 pounds (49.9kg) in shipping
carton

Packing Instructions

In the event it is necessary to repack the equipment for shipment, the equipment must be packed exactly as received. Failure to do this will result in shipping damage.

Use the original shipping carton and interior parts only if they are all in good serviceable condition. If a shipping carton or any of the interior part(s) are needed, please call or write Customer Service Department of McIntosh Laboratory.

McIntosh[®]

McIntosh Laboratory, Inc.
2 Chambers Street
Binghamton, NY 13903

McIntosh Part No. 040755