

Connecting the Phantom III to Your System

Krell recommends using balanced interconnect cables. Balanced interconnect cables not only can minimize sonic loss but are also immune to induced noise, especially with installations using long cables. Balanced connections have 6 dB more gain than single-ended connections. When level matching is critical, keep this gain value in mind.

Operating the Phantom III

Channel Balance Adjustment

Position the preamplifier where you intend to use it in your system.

1. Neatly arrange and organize wiring to and from the preamplifier and all components. Separate the AC wires from any audio cables to prevent hum or other unwanted noise from being introduced into the system.
2. Connect the outputs of your source equipment to the appropriate balanced (11), or single-ended inputs (12) on the Phantom III.
3. Connect the main outputs (13) on the Phantom III to your amplifier's inputs.
4. Connect the supplied AC power cord to the IEC power cord receptacle (17) of the preamplifier.
5. Plug the other end of the AC power cord into AC power and turn on the rear power switch. The display (3) shows PHANTOM III SOFTWARE VERSION, and the stand-by/power LED (4) illuminates red, indicating that the Phantom III is in stand-by mode. When the display shuts off, the Phantom III is ready to be powered on.

Note

Use only the power cord provided with the Phantom III to make the connection to AC power. Operation with a power cord other than the one supplied by Krell can induce noise, limit current, or otherwise impair the ability of the preamplifier to perform optimally.

After the Phantom III is connected to your system and to AC power you may begin operation:

1. Press the power button (1) on the front panel, or the remote control power key. The standby/power LED turns blue. The display shows the factory default input: S-1, and level: 000. The Phantom III is now in the operational mode.
2. With the preamplifier output muted, or the volume fully attenuated, select a source manually using the front panel input select buttons (5 or 6) or the remote input select keys. Start playing the source. Use the level control knob (10) or the remote level keys to set the volume to a comfortable level.
3. To return the preamplifier to the stand-by mode, press the power button (1) or remote power key. (We recommend leaving the Phantom III in the stand-by mode when it is not playing music.)

The balance function allows adjustment of the left and right balance. The options are: CENTER, L .5-5 dB <, R .5-5 dB >. The remote control has direct keys (D) to make these adjustments. For front panel adjustment follow the steps listed below.

1. Press the preamplifier menu button (9), then use the level control knob, or the remote control up and down keys to select: BALANCE.
2. Press the enter button (8) or remote enter key. The display shows the default mode: CENTER.
3. Use the level control knob, or the up and down keys, to select the desired balance option from 0 to +5 dB in .5 dB increments, left or right.
4. Press the enter button or key to confirm the selection. The display reads: BALANCE.
5. Press the menu button to exit the menu.



Phantom III Stereo Preamplifier

QUICK SETUP GUIDE

Getting Started

The owner's reference for this product, including a detailed description of features, technologies, and warranty is available on the web at: www.krellonline.com

Overview

Thank you for your purchase of the Krell Phantom III Stereo Preamplifier. The Phantom III features Krell Current Mode circuit topologies, balanced technology, and a robust power supply for exceptional audio performance. The Phantom III preamplifier is the first Krell preamplifier to include an optional digital input module. It is also the first Krell preamplifier to include a headphone output. A thoughtful suite of menu options ensures that the Phantom III can be customized for the greatest ease of operation.

The preamplifier's front panel provides power, input selection, level control, menu functions, and status display. The rear panel allows connection to audio sources, power amplifiers, AC power, and other system components.

The remote control provides power, preamplifier, level control, navigation and customization functions, CD and DVD player controls and menu configuration.

WARNINGS



This product complies with the EMC directive (89/336/EEC) and the low-voltage directive (73/23/EEC).

This CLASS 1 apparatus must be connected to a MAINS socket outlet with a protective earthing connection.

Do not place the preamplifier where it could be exposed to dripping or splashing.

Do not remove or bypass the ground pin on the end of the AC cord. This may cause radio frequency interference (RFI) to be introduced into your playback system.

The ventilation slots on the top and bottom of the preamplifier must be unobstructed at all times during operation. Do not place flammable material on top of or beneath the component.

Turn off all systems' power before connecting the preamplifier to any component.

Make sure all cable terminations are of the highest quality, free from frayed ends, short circuits, or cold solder joints.

THERE ARE NO USER-SERVICEABLE PARTS INSIDE ANY KRELL PRODUCT

Unpacking

Note

Save all packing materials. If you need to ship the Phantom III in the future, repack the unit in its original packaging to prevent shipping damage.

1. Open the shipping box and remove the top layer of foam. You will see these items:

1 Preamplifier chassis	2 AAA remote batteries
1 IEC connector (AC power) cord	1 T-10 Torx wrench for remote
1 Remote control	1 Quick Setup Guide

2. Carefully remove all items from the shipping box.
3. Place the preamplifier in a safe location and remove the protective plastic wrapping.

Placement

We recommend that you place the preamplifier on a firm, level surface, away from excessive heat, humidity, or moisture. The preamplifier requires at least two inches (5 cm) of clearance on each side and at least two inches (5 cm) of clearance above to provide adequate ventilation. Installations inside cabinetry may need extra ventilation.

AC POWER GUIDELINES

The Phantom III preamplifier has superb regulation and does not require a dedicated AC circuit. Avoid connections through extension cords or multiple AC adapters. High quality 15 amp AC strips are acceptable. The use of AC line conditioning devices is not recommended. The features provided by these devices are already on board the Phantom III.

MODEL **Phantom III Preamplifier** SERIAL NUMBER _____

Figure 1 The Phantom III Front Panel

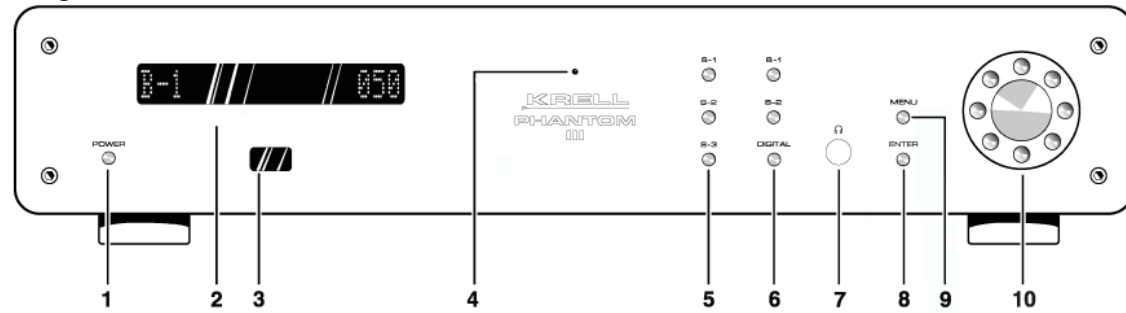

Front Panel

- 1 Power**
Use this to switch the preamplifier between stand-by and operational modes.
- 2 Display**
This provides channel status messages, including input selection, volume level, balance offset, and menu selections.
- 3 Infrared sensor**
This receives commands from the remote control. Make sure this is not obstructed.
- 4 Stand-by/Power LED**
This preamplifier LED illuminates red (stand-by) when the Phantom III is plugged into a standard AC wall receptacle and rear power switch is on. The LED illuminates blue (operational mode) when the power button (1) is pressed while the Phantom III is in stand-by mode.
- 5 Analog Input selectors**
Use these to select the corresponding rear panel input that is connected to a single-ended (S-1, S-2, S-3), or balanced (B-1, B-2) analog source. The display (2) shows the selected input and volume level. Pressing the input button on the active source will mute all outputs. A second press will unmute the outputs.
- 6 Digital Input selector (functional with optional D/A converter module)**
Use this to select the D/A converter module. Pressing and holding the digital button will cycle through the additional digital inputs.
- 7 Headphone Jack**
1/4" stereo headphone jack. The main outputs are muted when headphones are being used.
- 8 Enter button**
Use this to configure the menu functions of the Phantom III. See menu (9).
- 9 Menu button**
Use this to access the menu functions of the Phantom III. For more information, see *Customizing the Phantom III*, in the owner's reference.
- 10 Level control knob**
Use this knob to increase or decrease system volume level. The level control knob or keys also select menu options that customize the Phantom III.

Remote Control

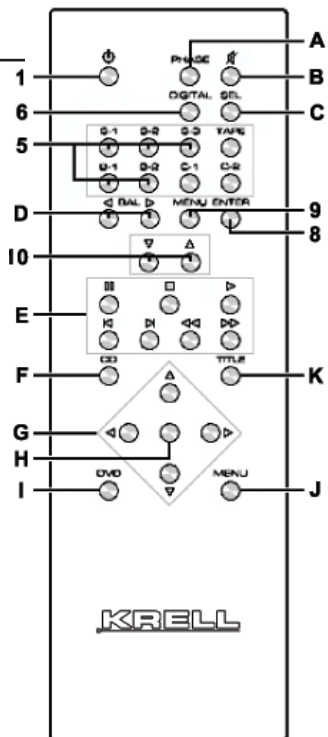
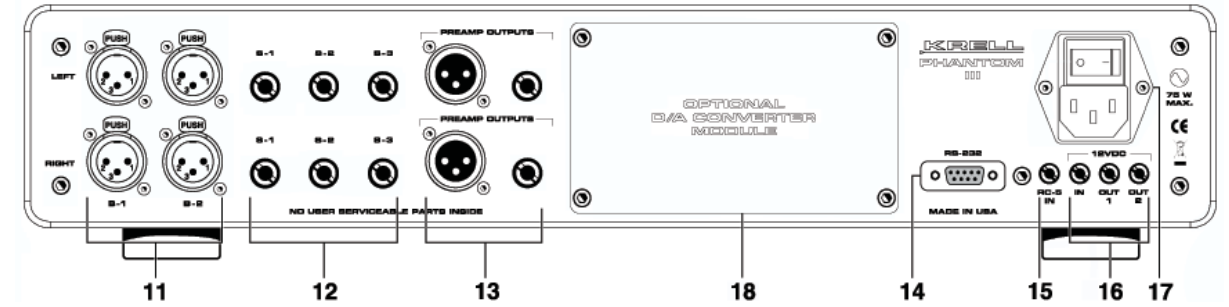

Figure 2 The Phantom III Remote Control

- Keys labeled 1 to 10**
have the same function (and callout number) as the front panel controls.
 - Keys labeled A through K**
are unique to the remote control, and are described below:
 - A Phase key**
Inverts the polarity of the audio signal. A lowercase i is displayed when the polarity is inverted.
 - B Mute key**
Use this mute all outputs. A second press of the mute key will unmute the outputs.
 - C Sel(ect) key**
Cycles through the digital inputs. This is only active when the optional D/A converter module is installed.
 - D Bal(ance) keys**
Use to balance left and right output levels.
 - E Transport keys**
These keys are functional with all Krell CD and DVD players.
 - F CD key**
Press this to make the transport keys operate Krell CD players.
 - G Direction keys**
Use these keys to navigate CD and DVD menus.
 - H Select Key**
Use this to make selections from CD and DVD menus.
 - I DVD key**
Press this to make the transport keys operate DVD players.
 - J Menu key**
Use this to enter CD or DVD player menus.
 - K Title key**
Use this with CD or DVD player menus.
- Note**
The remote is shipped with two AAA batteries that have to be installed. Use the supplied Torx wrench to remove the battery panel, then install the batteries.

Figure 3 The Phantom III Back Panel



Back Panel

- 11 Balanced inputs: B-1 and B-2**
These XLR balanced analog source input connectors are wired as follows:
Pin 1 Ground
Pin 2 Non-inverting
Pin 3 Inverting
- 12 Single-ended inputs: S-1, S-2, and S-3**
There are 3 single-ended analog source inputs with RCA connector pairs.
- 13 Main outputs**
The Phantom III is equipped with one balanced XLR output pair and one single-ended RCA output pair.
- 14 RS-232 port**
This port receives messages from a computer-based control system, providing integrated control of all preamplifier functions. For details, see the developer's reference: *RS-232 Port: Sending Commands and Interpreting Data*.
- 15 RC-5 in**
This remote connector is used with third-party remote control systems that provide RC-5 (IR) data via a wired connection. A stereo tip, ring, sleeve 1/8" mini connector is used in the following configuration:
Tip = RC-5 data
Ring = +5 V
Sleeve = GND.
- 16 12 VDC in/out (12 V trigger)**
There are 2 outputs and one input that send and receive 12 VDC power on/off (trigger) signals to and from other Krell components, and other devices that incorporate a 12 V trigger. This allows other components to be turned on/off, or to/from stand-by, through the remote control. For more information, see *Input Trigger* in the owner's reference.
- 17 IEC power cord receptacle and power switch**
This is for use with the provided AC power cord. Plug the other end into an AC Mains supply capable of supplying the correct AC voltage and current for the power supply. This connector and power cord must remain unobstructed for easy removal in case of an emergency.
- 18 Optional D/A Converter Module**
Location for future plug in D/A converter module.

Customizing the Phantom III

Configurable Functions

- AC Mains
 - Balance (channel)
 - Balance (input trim)
 - Display, Info
 - Input Level Trim
 - Input Name, Input Phase
 - Input Trigger, Mute, Output Trigger, Recall, Save, Theater.
- The menu button or key (9) allows you to configure functions. Enter the menu to view the list of configurable functions. Select a function to view a submenu of the list of options that configure the function. You can configure some options as well, if a second submenu appears when you select an option.

Navigation Conventions

- Navigating the preamplifier menu is straightforward and consistent throughout, using 4 functions and the menu option BACK.
- 9 Menu Button or Key**
To enter the menu, press the menu button or key. Once you are in the menu, you can press the menu button or key to exit the menu.
 - 10 Level Control Knob or Up and Down Keys**
Use the level control knob or the up and down keys on the remote control to scroll forward and backward through the menu hierarchy. Each menu list is a continuous loop.

- 8 Enter Button or Key**
Press this button or key to select a function or a configuration option, and confirm a selection
- 3 Front Panel Display**
The display shows the active function and configurable options.
- BACK**
Select BACK to scroll backwards through the menu hierarchy, or to exit a menu option without confirming that option.

For more information on menu configuration, review the Owner's Reference on the Krell website at www.krellonline.com. Navigate to Downloads/ Current, then select the Phantom III from the product list. The publication list for the Phantom III appears.