

Price: \$5.00

MODEL SP14 PREAMPLIFIER

OWNER'S MANUAL

1-15-89

audio research corporation

6801 SHINGLE CREEK PARKWAY
MINNEAPOLIS, MINNESOTA 55430

TABLE OF CONTENTS

<u>SECTION</u>	<u>PAGE</u>
PREFACE	1
INTRODUCTION	1
CONSTRUCTION AND TESTING	1-2
WARNINGS	2
PACKAGING	2
TUBE COMPLEMENT	2
DESCRIPTION OF CONTROLS	2-4
CONNECTIONS - PREAMPLIFIER	4-5
INPUT IMPEDANCE ADJUSTMENT	5
INPUT CAPACITANCE ADJUST (WITH ILLUSTRATION)	5-6
CONNECTIONS - AC POWER	6
INSTALLATION INSTRUCTIONS	6-7
OPERATING PROCEDURE	7-9
SERVICING	9
CLEANING	9
WARRANTY TERMS AND CONDITION	10-11
WARRANTY OUTSIDE THE USA	11
SPECIFICATIONS	12
ADDENDUM: SCHEMATIC	

PREFACE

Please take the time to carefully read this Instruction Manual prior to installation or use of your SP14 preamplifier. Because it is a technically unconventional, highly advanced electronic instrument, there are several facts and procedures you should know before you place it in operation.

Just as you would not purchase and attempt to operate an expensive camera, computer system or high-performance automobile without first learning something about performance parameters and correct operating procedures, so too your SP14 preamplifier requires some familiarization before you make it part of your music reproduction system. Your reward, in terms of maximum performance and a long service life, will be well worth the effort.

INTRODUCTION

The SP14 hybrid stereo preamplifier continues the Audio Research Corporation tradition of advanced preamplifier designs offering both state-of-the-art performance and real-world practicality. It offers not only stunningly detailed resolution and life-like musical dynamics, but also a truly useful range of controls and features -- all within a solidly-engineered, handcrafted mechanical package realistically designed for years of service and enjoyment.

The SP14 is a hybrid design, using one (1) 6DJ8 dual triode vacuum tube in an intermediate gain stage of the phono section. This single vacuum tube helps provide the effortless phono gain and dynamics that Audio Research preamplifiers have long been noted for.

The high level, or line section, of the SP14 is an all Field Effect Transistor design, similar to the circuitry found in the SP9 and SP15 preamplifier models, and offers a similar level of musical resolution -- adequate for the finest input sources available today.

The power supply features extensive electronic regulation together with a low-noise toroidal power transformer. Mechanical shielding and careful internal layout minimize electromagnetic interference upon sensitive circuitry.

The SP14 offers a complete range of practical controls for the music system that requires extensive flexibility. From a highly useful attenuator-gain control combination, to an ultra-pure "bypass" mode, to comprehensive tape handling functions, the SP14 provides wide control over an audio system while maintaining "purist" sonic standards.

In short, the SP14 represents an advance in value as well as in state-of-the-art music reproduction. It should provide its owner with many years of satisfaction in quality music reproduction.

CONSTRUCTION AND TESTING

Like every Audio Research product, your SP14 preamplifier has been designed and carefully handcrafted in the U.S.A., using precision mechanical parts, electronic components and assembly procedures similar to those used in the manufacture of military electronics, aircraft electronics and scientific instruments. To assure

performance standards, each SP14 is visually inspected at several assembly points, test run, electronically tested and sonically evaluated prior to shipment.

This time-consuming "perfectionist" approach to the design and manufacture of audio equipment is intended to provide you with the best in musical satisfaction and lasting value.

WARNINGS

1. To prevent fire or shock hazard, do not expose your SP14 to rain or moisture.
2. This unit contains voltages which can cause serious injury or death. Do not operate with covers removed. Refer servicing to your authorized Audio Research dealer or other qualified personnel.
3. The power cord on your SP14 is equipped with a standard three-prong grounding plug. If used normally, it will provide a safe earth ground connection of the chassis and all equipment plugged into its AC receptacles on the rear panel of the power supply chassis. Refer to the Section on Grounding Instructions for detailed information. (Units supplied to the United Kingdom will not have these receptacles.)
4. For continued protection against fire hazard, replace fuses only with the same type and rating of fuses as specified at individual fuse holders.

PACKAGING

Save all packaging in a dry place away from fire hazard. Your SP14 preamplifier is a precision electronic instrument and should be properly cartoned any time shipment is made. You may not have occasion to return your unit to the factory for service, but if that should prove necessary, or other occasion requiring shipment occurs, the original packaging will protect your SP14 from unnecessary damage or delay.

Note that your SP14 has been shipped with the vacuum tube installed in its proper high-retention socket. You may do likewise if the complete original packaging is used for shipment.

TUBE COMPLEMENT

One (1) 6DJ8 vacuum tube is used in the phono section of the SP14, pre-installed at location V1 on the main preamplifier circuit board. See Servicing for information on replacement tubes.

DESCRIPTION OF CONTROLS

GAIN CONTROL: A detented control used to attenuate the input to the preamplifier Line Section. Allows essentially unlimited signal input range while preserving optimum use of Attenuation Switch. (Use as "volume" control.)

ATTENUATION SWITCH: A segmented switch used to preset the operating range of the Gain Control. The Attenuation Switch operates in 6dB increments, down to -24dB.

For maximum sonic quality: Rotate Attenuation Switch clockwise to maximum setting ("0" attenuation), then use Gain Control to adjust volume.

NOTE: Mute between records. Activate Mute and turn Gain down when switching inputs for maximum protection.

BALANCE CONTROL: When rotated, adjusts the relative sound levels of the left and right channels. A detent at the 12 o'clock position marks the point of equal balance. Rotating the knob to the right decreases the level of the left channel proportionally, shifting the sonic image to the right. Rotating the knob to the left shifts the sonic image to the left.

MODE CONTROL: Allows selection of various single-channel (mono) and two-channel (stereo) listening modes. Detents mark each selection option during rotation of knob. "Mono" reproduces identical sonic information on both right and left channels. "Reverse" switches left-channel information to the right, right-channel information to the left. "Stereo" is the normally preferred mode for most program material, producing the most realistic sonic image. "Left" cancels all right-channel information, and presents left-channel information to both channels. In the same way, "Right" cancels all left-channel information, etc.

RECORD OUT: Selects input source for presentation to Recorder Outputs when "Copy/Normal" switch is in "normal" position. Used for making recordings from Phono, CD, Tuner, or other input sources.

INPUT SELECTOR: Detents mark selection of various source material options: "Phono" for phonograph record turntables; "CD" for compact digital disc players; "Tuner" for radio tuners; "Video" for input from Beta or VHS videotape recorder/players; and "Auxiliary" for any additional high level source: tape, tuner, CD, video, etc.

POWER/OFF SWITCH: Initiates power to preamplifier. Function indicated by green LED centered in row of toggle switches. (See "Power/Muting Circuit LED.")

OUTLETS/OFF SWITCH: Initiates power to two (2) grounded receptacles on rear panel of chassis. Note that one (1) additional grounded receptacle, unswitched, is also provided on the rear panel. (See Section on "Power Receptacles.")

BYPASS/NORMAL SWITCH: In "Bypass" mode, directly connects the Attenuation Switch and Gain Control to the source selected by the Input Selector. The Balance and Mode Controls, as well as the Monitor/Source Switch, are removed from the active circuit path when this switch is in operation. Use "Bypass" whenever maximum fidelity to the input signal is desired. (The SP14 has about 1dB lower gain in the "normal" mode.)

MUTE/OPERATE SWITCH: In "Mute" position, shorts the output of the preamplifier to allow listening interruptions for telephone answering or other reasons. This switch should always be activated between listening uses, in addition to turning the Gain (volume) Control counter-clockwise. These two simple precautions will prevent inadvertent misuse of your SP14 and help protect against damage to your power amplifier and/or speakers by unexpected transient signal pulses (tone arm mishandling, etc.).

POWER/MUTING CIRCUIT LED: Glows green to indicate unit is on and receiving power from the power supply. Note that for approximately 45 seconds after start-up or in "Mute" mode, this LED will glow more dimly, indicating proper operation of the muting circuit. In the "Operate" mode (after warm-up), the LED brightens and your SP14 is ready for normal operation.

COPY/NORMAL SWITCH: In the "Normal" position, the signal source selected by the Record Out Selector is presented at the Recorder Outputs. When two tape recorders are used in the system and tape copying or dubbing is desired, move the switch to the "Copy" position. This allows you to tape from one deck to another and simultaneously listen to another program source. "Copy" connects the Recorder Outputs to the "Tape 1" or "Tape 2" inputs as selected by the 2-1/1-2 switch.

2-1/1-2 SWITCH: Used with the Tape 2/Tape 1 Switch. Position "2-1" connects the outputs of tape recorder #2 to the inputs of tape recorder #1; position "1-2" connects the outputs of tape recorder #1 to the inputs of tape recorder #2.

TAPE 2/TAPE 1 SWITCH: Used with the Copy/Normal Switch. Selects either "Tape 1" or "Tape 2" inputs and connects the choice to the Monitor/Source Switch.

MONITOR/SOURCE SWITCH: In "Monitor" position, this switch -- as determined by the Tape 1/Tape 2 Switch -- presents the output signal from a tape recorder to the Main Outputs. In the "Source" position, the program source presented is controlled by the Input Selector (Phono, CD, Tuner, etc.).

Note that the Monitor Switch is not functional when the Bypass Switch is activated.

CONNECTIONS - PREAMPLIFIER

INPUT CONNECTORS: All are clearly marked to indicate use. All high level inputs are 50K ohms impedance. "Phono" input impedance as shipped from the factory is 47K ohms in parallel with 560pF capacitance. See "Input Impedance Adjustment" to change these values. Note that inputs for two (2) tape recorders are provided, as well as inputs for tuner, compact disc, video and a spare line-level input. All Input/Output connectors are gold plated and connect "ground" before "hot." On disconnect, "hot" is disconnected first.

MAIN OUTPUT CONNECTORS: There are two (2) sets of output connectors which are connected internally in parallel. One set should be connected to your electronic crossover or power amplifier. The additional set is provided for connection to an additional amplifier for remote or "background" use, or for "bi-wire" amp systems (where separate power amplifiers are used for bass and treble, but no electronic crossover is used).

Minimum total load for the output connectors should not be less than 20K ohms for maximum sonic performance.

Note: At the performance level of the SP14, high-quality audio signal interconnect cables are critical to preserving maximum fidelity. Audio Research Litzlink RFI-shielded or unshielded interconnect cables are highly recommended for connection to your power amplifier and to other ancillary equipment. See your authorized Audio Research dealer for recommended lengths and prices.

RECORDER OUTPUT CONNECTORS: Two (2) sets are provided. These outputs should be connected to your tape recorder's "AUX" or "LINE" inputs. These outputs supply a low-impedance source of whatever is selected by the "Record Out" Control on the front panel. Level is non-variable and equal to the selected input source.

INPUT IMPEDANCE ADJUSTMENT

For the best sonic performance from your phono pickup cartridge, it should connect to the proper load impedance as recommended by the cartridge manufacturer. Your SP14 comes wired with 47K ohms and 560pF for many high-output, moving-coil and moving magnet cartridges. A kit of precision load resistors is supplied with your SP14 for the load requirements of 30, 60, 100, 200 or 800 ohms moving-coil cartridges. Consult your cartridge manufacturer or dealer to determine the optimum load impedance for your needs. You may wish to connect the load resistors at the output of your turntable, rather than in the SP14, especially if you may be using more than one turntable or cartridge, with different load requirements.

The use of precision fixed resistors provides better load accuracy and sonic performance at lower cost than most adjustable or switchable loads. Audio Research can supply audiophile grade non-standard load resistor and capacitor values upon request accompanied by US\$10.00 to cover order processing costs (certified funds or money order).

Solder the desired resistors (one, or two per channel [in parallel], as required) to the turret terminal posts on the bottom of the main circuit board near the phono inputs (see illustration next page). First wrap the resistor leads around the posts 1/2 to 3/4 turn. Then solder using the special alloy solder supplied with the resistors. Connect the desired resistor combination between the left and center posts and again between the center and right posts.

For 30 ohms: Add brown-black-black-black and yellow-orange-red-gold resistors.
For 60 ohms: Add brown-black-black-black and brown-green-black-black resistors.
For 100 ohms: Add brown-black-black-black resistors.
For 200 ohms: Add red-black-green-black and brown-black-black-red resistors.
For 800 ohms: Add brown-black-black-brown and yellow-orange-red-brown resistors.

NOTE: All SP14s have two 560 picofarad capacitors mounted on the impedance loading pegs, one for each channel. When using moving coil cartridges, these capacitors should not be removed when adding load resistors. The load resistors should be installed in parallel with these capacitors.

INPUT CAPACITANCE ADJUSTMENT

The SP14 has a total input capacitance of 600 Picofarads with the 560 picofarad capacitors installed and 40 picofarads without them. Different value capacitors can be installed to match the requirements of your moving magnet cartridge. Observe the polarity as shown in the diagram on the next page when adding capacitors.

SP14
Bottom view,
rear corner.

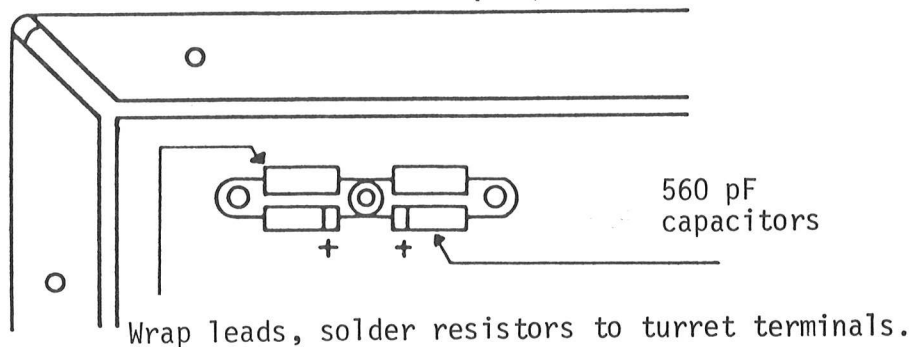

CONNECTIONS - AC POWER

POWER RECEPTACLES: Three (3) grounded receptacles are provided, rated for a total of 300 watts. There is one (1) unswitched outlet which can be used for a turntable or other equipment where switching is not needed or wanted. There are two (2) switched outlets, capable of providing power to ancillary equipment. (For maximum sonic quality it is recommended that power amplifiers be connected directly to the wall outlet.

The line cord is a #16-gauge, 3-conductor cable, providing ample safe grounded power to the rear panel receptacles. It should be noted that the SP14 line cord not only grounds the convenience outlets, but also the preamplifier chassis as well. Do not attempt to defeat the ground power plug.

FUSES: For maximum safety and protection of your warranty, always use the same size and type of fuses as indicated on the back of the chassis.

INSTALLATION INSTRUCTIONS

While the SP14 does not dissipate an unusual amount of heat, it is important that it have a reasonable airflow to assure long, trouble-free operation. In addition, the following installation guidelines will help insure maximum sonic performance as well as reliable service.

1. Upright and horizontal mounting is required if extended operation (longer than one hour) is contemplated.
2. Do not "stack" the SP14 on top of other equipment. Not only will this prevent proper ventilation, but "hum" may be introduced into the phono circuits from the proximity of the power transformer of the other equipment.

3. Do not place or operate unit on a soft or irregular surface such as a rug. This will prevent the unit from having proper ventilation.
4. Do not operate unit without the top and bottom covers installed. These are required both for safety as well as shielding from interference (except in service operations, obviously).
5. If rack mounting is employed, use Audio Research Rack Mount Ventilators (RMV-3) below and above the SP14.
6. In a cabinet or rack-mount installation which has an enclosed back, an exhaust fan is desirable so as not to operate the SPL4 in overheated ambient air. Operation of vacuum tube equipment for long periods of time in hot ambient air will shorten tube life and increase chance of failure of other components parts.

OPERATING PROCEDURE

START-UP:

1. Make sure power switch and receptacle power switch on SP14 are set to "off" position; Mute Switch should be in "mute" position and "Gain" Control should be at minimum (full counter-clockwise rotation).
2. Secure all rear-panel connections between SP14, power amplifier(s) and input sources. Note: Given the advanced performance capabilities of the SP14, it is extremely important that the highest-quality interconnects be used for connection to ancillary electronics. Audio Research LITZLINK[®] brand interconnects, in either unshielded or RFI-shielded configurations, are strongly recommended. Your Audio Research dealer can assist you in determining optimal lengths for your system.
3. Plug 3-prong powerline cord from rear of SP14 into AC wall receptacle.
4. Turn Power Switch on SP14 to "On." Turn receptacle Power Switch to "on" as necessary. Green LED will stay dim for approximately 45 seconds while power supply stabilizes, indicating operation of automatic muting circuit. When LED brightens, your SP14 is ready for operation.

Note: For superior sonic performance, a warm-up period of approximately one hour is recommended. In addition, your SP14 may be safely left "on" continuously for maximum performance at all times, but at the expense of higher maintenance costs (more frequent tube replacement).

5. Rotate input selector to source desired; set switch options to positions desired.
6. Activate input source, then deactivate Mute Switch and adjust "Attenuation" and "Gain" controls as necessary.

MUTING PROVISIONS:

The SP14 has several provisions to help protect against misuse of the exceptional dynamic range and wide bandwidth that it offers. It is not subject to damage itself, but some power amplifiers and speakers are more limited in their ability to withstand signal extremes. These provisions, both manual and automatic, are designed not to

interfere with a flawless listening experience of unprecedented realism, while giving reasonable protection against warm-up surges and power line interruptions. However, for absolute protection of associated equipment some operator understanding, and responsibility is required.

Initial "settling" time of all circuit parameters within the SP14 requires approximately 10 minutes. The automatic muting circuitry timer is adjusted for about 45 seconds. (This is because recurrent interruption "settling" time is much less. You would not want to wait for 10 minutes each time such an interruption occurred.)

The Mute/Operate Switch allows manual disabling of the SP14 outputs during any moving of the tonearm or switching of equipment. Use of this switch will minimize stress on your amplifier even if it is "off." It is also highly recommended that manual muting be employed during the initial 10 minute warm-up period as well as during turnoff for maximum protection.

While it is true that the automatic muting will provide reasonably adequate protection against speaker burnout during these periods, it has limitations. Consider the following: Suppose the power amplifier is "on" (although this should not be) when the SP14 is turned on (without manual muting). There is a finite period of time prior to the energizing of the automatic muting circuitry which will allow a few milliseconds of warm-up settling at the output. The result is sonic and subsonic output to the amplifier and speaker. While this won't normally cause loudspeaker or amplifier failure, it will be sonically unpleasant. Again, at the 45 second point, the automatic timer "releases" the output, and since full stabilization has not yet occurred, the sonic unpleasantness is repeated. Although this is normally adequate "protection," utilization of the manual mute provision will completely avoid this stress to your speakers, as well as the associated sonic unpleasantness.

Some solid-state power amplifiers have a DC offset present at their input connections. (This, of course, should not be.) Operation of the manual muting switch with such an amplifier connected will result in a "click" or "pop" in your loudspeaker (commensurate in level with the amount of the offset) each time the switch is activated. Repair or replacement of such amplifiers is suggested.

The automatic muting operates as follows:

1. The manual mute switch always disables both outputs and overrides any automatic provisions, even when the SP14 is turned off. (The "Operate" position of the manual mute switch is functional only when the unit is not in the automatic mute mode.)
2. The 45 second warm-up timer will restart automatically if the power is temporarily interrupted for 0.2 seconds or more. Note: Power supply regulation of the SP14 is effective down to 95VAC without serious sonic degradation.
3. The automatic muting of the SP14 is designed to be effective only against power line interruptions and power supply failures. it will not mute against subsonic signal transmissions from your turntable, etc. Proper fusing of speakers is essential to protect against excessive audio level or power amplifier faults.
4. The muting is accomplished by shunt relays activated by the automatic timer circuit, or manually via the Muting Switch. This design insures minimal sonic degradation.

SHUT DOWN:

1. Set "Mute" Switch to "mute" position.
2. Rotate the "Gain" Control counter-clockwise to minimum setting.
3. Deactivate power amplifier(s).
4. Deactivate all input sources.
5. Set SP14 Power Switch and Receptacle Power Switch to "Off" position.

SERVICING

Because of its careful design and exacting standards of manufacture, your SP14 should normally require only minimal routine service to maintain its high level of performance.

CAUTION: Your SP14 contains sufficient levels of voltage and current to be lethal. Do not tamper with a component or part inside the unit. Even with the power turned off, a charge remains in the energy storage capacitors for some time. Refer any needed service to your authorized Audio Research dealer or other qualified technician.

The vacuum tube inside your SP14 is a quality 6DJ8 type, and with normal use should not have to be changed for approximately 5000 to 10,000 hours of use. A replacement 6DJ8 tube need not be selected for low noise. However, a good, high-transconductance tube from Audio Research will provide superior sonic performance.

At the back of this Manual you will find a schematic diagram for your SP14 which is fully annotated with operating voltages and component parts values. Your service technician will require this information when servicing your unit.

Note: Contact enhancers - such as the commercial preparation "Tweek" - are not recommended for use on vacuum tube contact pins. With continual exposure to heat and air, these substances can form gummy, dust-collecting residues which actually reduce contact and degrade sonic performance. Proper external use of these preparations -- on interconnect plugs, speaker connections, etc. -- is subject to the discretion of the owner.

CLEANING

To maintain the visual appearance of your SP14 preamplifier, occasionally wipe the front panel and top cover surfaces with a soft, damp (not wet) cloth to remove dust. A mild, non-alkaline soap solution may be used to remove fingerprints or similar smudges. Cleaners containing abrasives should not be used as they will damage the "brushed" grain of the front panel finish.

3-YEAR LIMITED WARRANTY TERMS AND CONDITIONS

1. LIMITED WARRANTY. Audio Research warrants the product designated herein to be free of manufacturing defects in material and workmanship, subject to the conditions hereinafter set forth, for a period of three (3) years from the date of purchase by the original purchaser or no later than five (5) years from the date of shipment to the authorized Audio Research dealer, whichever comes first, excepting vacuum tubes which are warranted for 90 days only (See 6).
2. CONDITIONS. This Warranty is subject to the following conditions and limitations. The Warranty is void and inapplicable if the product has been used or handled other than in accordance with the instructions in the owner's manual, abused or misused, damaged by accident or neglect or in being transported, or the defect is due to the product being repaired or tampered with by anyone other than Audio Research or an authorized Audio Research repair center. The product must be packed and returned to Audio Research or an authorized Audio Research repair center by the customer at his or her sole expense. Audio Research will pay return freight of its choice. A RETURNED PRODUCT MUST BE ACCOMPANIED BY A WRITTEN DESCRIPTION OF THE DEFECT AND A PHOTOCOPY OF THE ORIGINAL PURCHASE RECEIPT. This receipt must clearly list model and serial number, the date of purchase, the name and address of the purchaser and authorized dealer and the price paid by the purchaser. Audio Research reserves the right to modify the design of any product without obligation to purchasers of previously manufactured products and to change the prices or specifications of any product without notice or obligation to any person.
3. REMEDY. In the event the above product fails to meet the above Warranty and the above conditions have been met, the purchaser's sole remedy under this Limited Warranty shall be to return the product to Audio Research or an authorized Audio Research repair center where the defect will be rectified without charge for parts or labor, except vacuum tubes (See 6).
4. LIMITED TO ORIGINAL PURCHASER. This Warranty is for the sole benefit of the original purchaser of the covered product and shall not be transferred to a subsequent purchaser of the product.
5. DURATION OF WARRANTY. This Warranty expires on the third anniversary of the date of purchase or no later than the fifth anniversary of the date of shipment to the authorized Audio Research dealer, whichever comes first.
6. VACUUM TUBES. Vacuum tubes are warranted for the original 90-day period only.
7. DEMONSTRATION EQUIPMENT. Equipment used by an authorized dealer for demonstration purposes is warranted to be free of manufacturing defects in materials and workmanship for a period of three (3) years from the date of shipment to the dealer. Vacuum tubes are warranted for 90 days. Demo equipment needing warranty service must be packed and returned to Audio Research by the dealer at his sole expense. Audio Research will pay return freight of its choice. A returned product must be accompanied by a written description of the defect on an AUDIO RESEARCH RETURNED GOODS AUTHORIZATION form. Dealer-owned demonstration equipment sold at retail within three (3) years of date of shipment to the dealer is warranted to the first retail customer to be free of manufacturing defects in materials and workmanship for the duration of the 3-Year Limited Warranty remaining (as measured from the date of shipment of the equipment to the dealer). Vacuum tubes are not warranted for any period under these conditions of sale. In the event warranty service is needed under these conditions,

the owner of the equipment must provide a copy of his purchase receipt, fulfilling the requirements described under "2. Conditions" above. The product must be packed and returned to Audio Research or an authorized Audio Research repair center by the customer at his or her sole expense. Audio Research will pay return freight of its choice.

8. MISCELLANEOUS. ANY IMPLIED WARRANTIES RELATING TO THE ABOVE PRODUCT SHALL BE LIMITED TO THE DURATION OF THIS WARRANTY. THE WARRANTY DOES NOT EXTEND TO ANY INCIDENTAL OR CONSEQUENTIAL COSTS OR DAMAGES TO THE PURCHASER. Some states do not allow limitations on how long an implied warranty lasts or an exclusion or limitation of incidental or consequential damages, so the above limitations or exclusions may not apply to you. This Warranty gives you specific legal rights, and you may also have other rights which vary from state to state.

9. WARRANTOR. Inquiries regarding the above Limited Warranty may be sent to the following address:

Audio Research Corporation
6801 Shingle Creek Parkway
Minneapolis, MN 55430

WARRANTY OUTSIDE THE USA

Audio Research has formal distribution in many of the countries of the free world. In each country the Audio Research Importer has contractually accepted the responsibility for product warranty. Warranty should normally be obtained from the importing dealer or distributor from whom you obtain your product.

In the unlikely event of service need beyond the capability of the Importer, Audio Research does, of course, back up the warranty. Such product would need to be returned to Audio Research, together with a photostatic copy of the bill of sale.

SP14 PRELIMINARY SPECIFICATIONS

Frequency Response:

High level section: $\pm .5$ dB, 5Hz to 50kHz
-3dB points below 1Hz and above 200kHz
Magnetic phono: $\pm .3$ dB of RIAA, 30Hz to 40kHz

Distortion:

Less than .01% at 2V RMS output

Gain:

Phono input to tape output: 46dB High level inputs to tape output: 0dB
Phono input to main output: 66dB High level inputs to main output: 20dB

Inputs (7):

Phono, C-D, Tuner, Video, Spare, Tape 1, Tape 2

Outputs (4):

(2) Main, (2) Recorder

Controls (6):

Gain, Attenuation, Balance, Mode, Record Out, Input

Switches (8):

Power, Outlets, Bypass, Mute, Copy, Tape 1 to 2/2 to 1, Tape 2/1, Monitor

Input Impedance:

50K ohms Line Inputs: 47K Phono (Phono provisions for any value below 47K ohms or added input capacitance for matching certain magnetic cartridges.)

Output Impedance:

250 ohms main output, 1000 ohms recorder output. Recommended load 60K-100K ohms and 100pF. (20K ohms minimum and 1000pF maximum)

Maximum Inputs:

Magnetic phono, 200mV at 1kHz (1000mV RMS, 10kHz). High level inputs essentially overload-proof.

Rated Outputs:

2V RMS 5Hz to 50kHz, all outputs; 60K ohm load (main output capability is 50V RMS output at 1/2% THD at 1kHz into a 100K ohm load with 5V RMS high level input)

Power Supplies:

Electronically-regulated low and high voltage supplies and electronic decoupling. Shielded toroid transformer. Line regulation better than .01%

Noise:

High Level

- (1) 70uV RMS maximum residual unweighted wideband noise at main output with gain control minimum (98dB below 5V RMS output)
- (2) More than 100dB below 1V RMS input (less than 7uV equivalent input noise)

Phono

0.12uV equivalent input noise, IHF weighted, shorted input (78dB below 1mV input)

Tube Complement:

1 - 6DJ8/ECC88 dual triode
(Hybrid FET/Tube audio circuit, solid-state power supply)

Power Requirements:

100-135VAC 60Hz (200-270VAC 50/60Hz) 60 Watts

Dimensions:

19" (48 cm) W x 5 1/4" (13.4 cm) H (standard rack panel) x 10 1/4" (26 cm) D.
Handles extend 1 5/8" (4.1 cm) forward of front panel. Rear chassis fittings extend 7/8" (2.3 cm).

Weight:

12 lbs. (5.5 kg) Net; 21 lbs. (9.6 kg) Shipping

SP14 PREAMPLIFIER

SCHEMATIC

1-15-89

audio research corporation

6801 SHINGLE CREEK PARKWAY
MINNEAPOLIS, MINNESOTA 55430

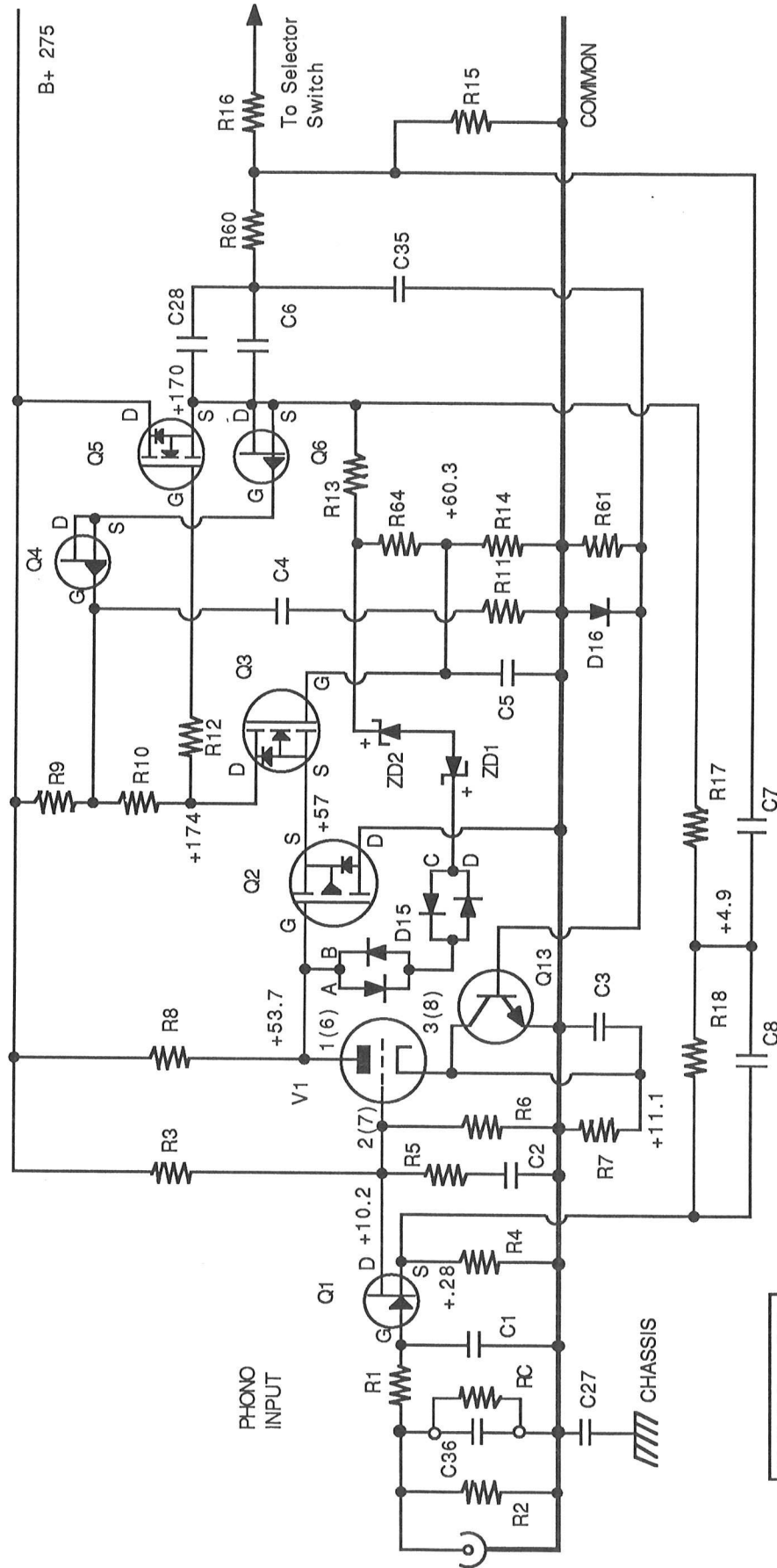

46dB Gain at 1kHz
RIAA Equalized

JAN. 25, 1989

© COPYRIGHT 1989

SP14 PREAMPLIFIER - (PHONO CIRCUITRY) - PAGE 1 of 4 PAGES

AUDIO RESEARCH CORPORATION
6801 SHINGLE CREEK PARKWAY
MINNEAPOLIS, MN 55430

PROPRIETARY NOTICE: THIS DRAWING CONTAINS PATENTED, PATENT PENDING, PATENT APPLIED FOR, AND/OR OTHER CIRCUITRY CONSIDERED PROPRIETARY BY AUDIO RESEARCH CORPORATION AND IS FURNISHED ON A CONFIDENTIAL BASIS FOR IDENTIFICATION PURPOSES ONLY.

B+285

FROM GAIN CONTROL

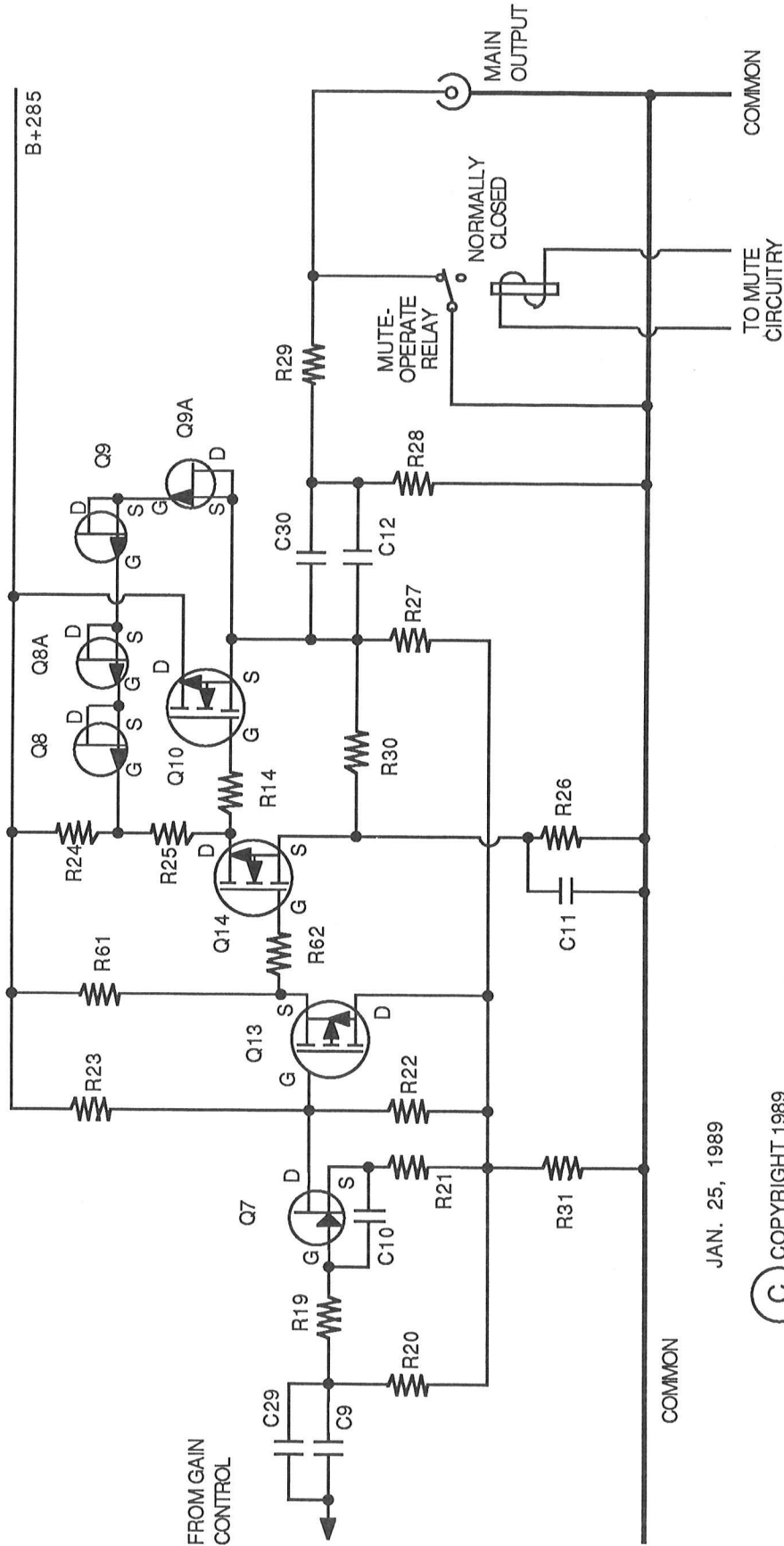

JAN. 25, 1989

© COPYRIGHT 1989

SP14 PREAMPLIFIER - (LINE SECTION CIRCUITRY) - PAGE 2 of 4 PAGES

AUDIO RESEARCH CORPORATION
 6801 SHINGLE CREEK PARKWAY
 MINNEAPOLIS, MN 55430

PROPRIETARY NOTICE: THIS DRAWING CONTAINS PATENTED, PATENT PENDING, PATENT APPLIED FOR, AND/OR OTHER CIRCUITRY CONSIDERED PROPRIETARY BY AUDIO RESEARCH CORPORATION AND IS FURNISHED ON A CONFIDENTIAL BASIS FOR IDENTIFICATION PURPOSES ONLY.

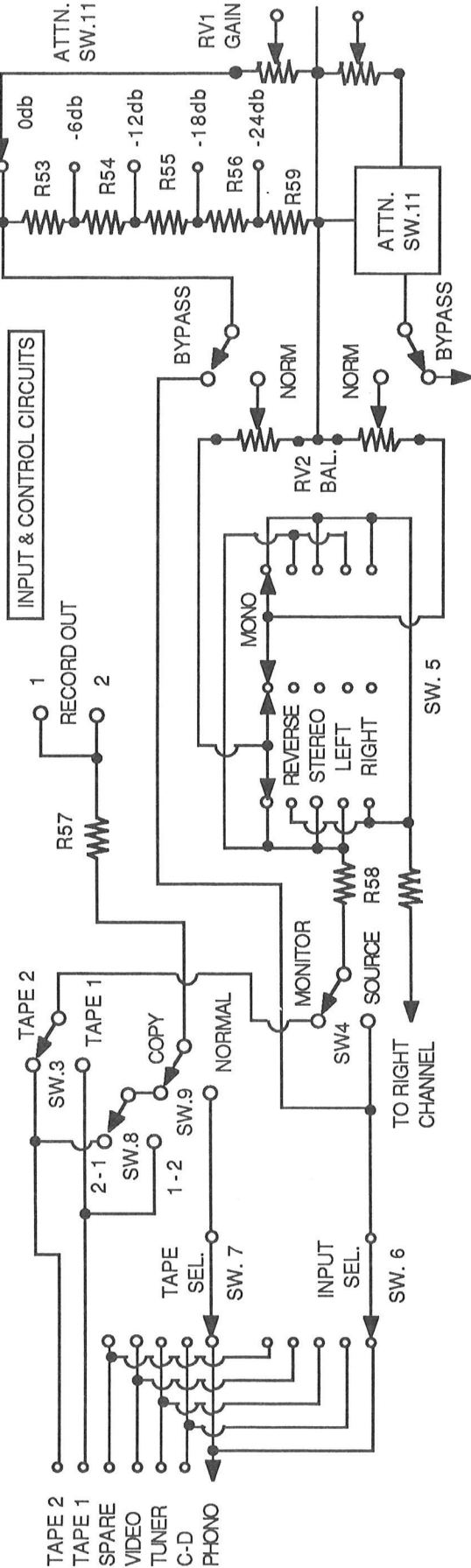
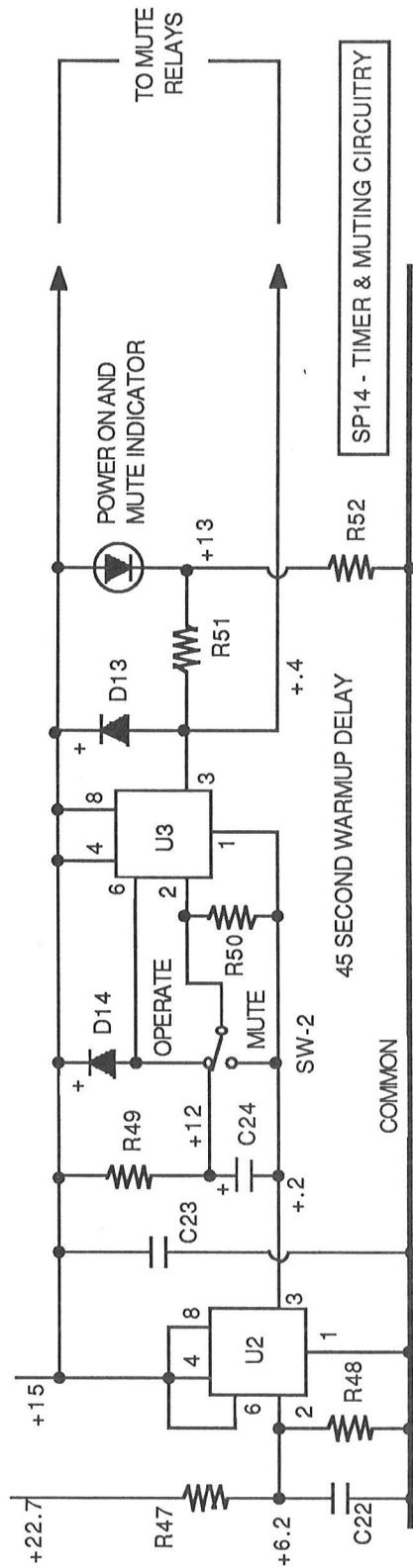

TO RIGHT INPUT SEL.

SP14 PREAMPLIFIER - (MUTING & SWITCHING CIRCUITRY) - PAGE 3 of 4 PAGES

JAN. 25, 1989 © COPYRIGHT 1989

PROPRIETARY NOTICE: THIS DRAWING CONTAINS PATENTED, PATENT PENDING, PATENT APPLIED FOR, AND/OR OTHER CIRCUITRY CONSIDERED PROPRIETARY BY AUDIO RESEARCH CORPORATION AND IS FURNISHED ON A CONFIDENTIAL BASIS FOR IDENTIFICATION PURPOSES ONLY.

AUDIO RESEARCH CORPORATION
 6801 SHINGLE CREEK PARKWAY
 MINNEAPOLIS, MN 55430

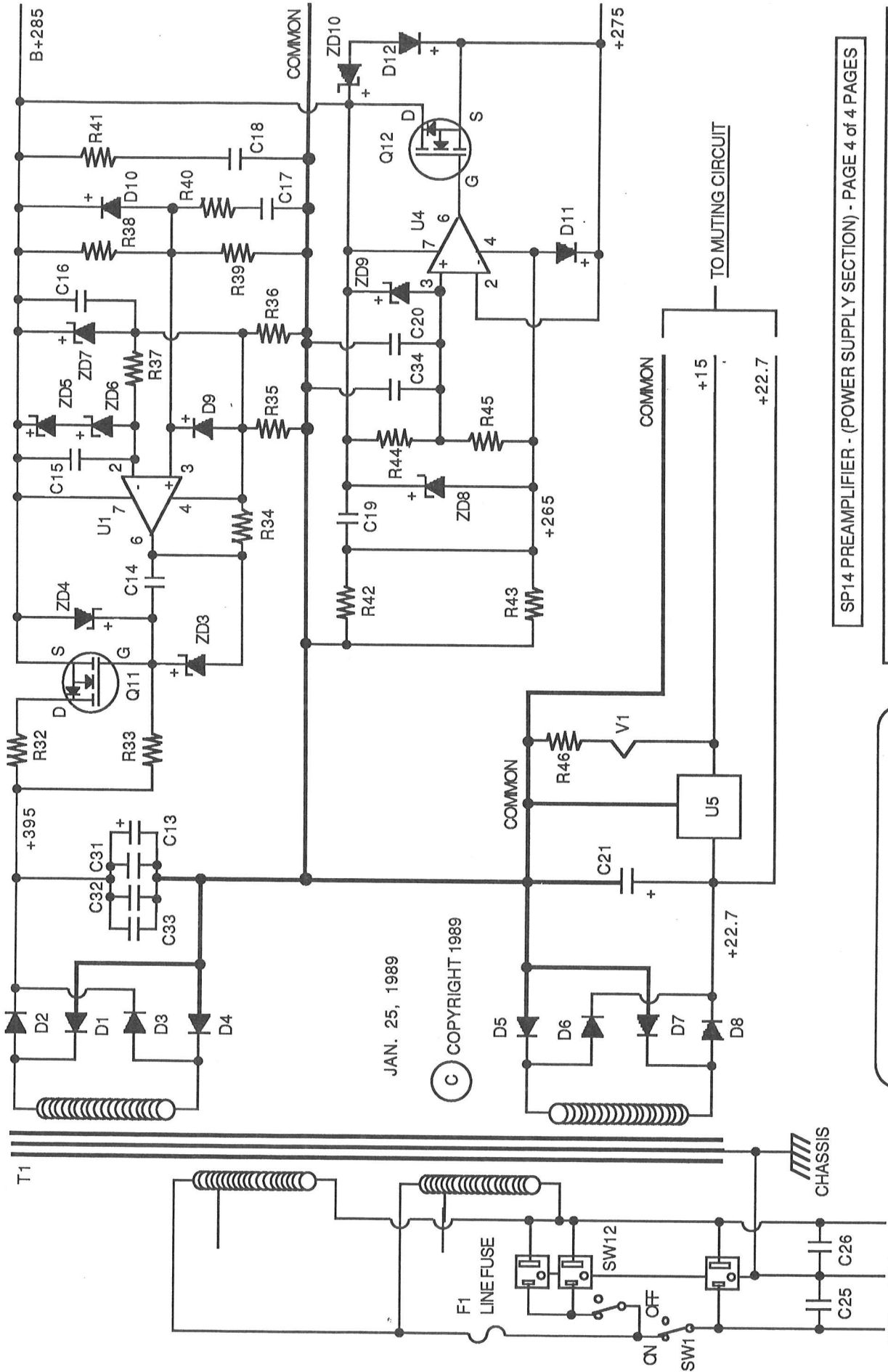

JAN. 25, 1989

© COPYRIGHT 1989

SP14 PREAMPLIFIER - (POWER SUPPLY SECTION) - PAGE 4 of 4 PAGES

AUDIO RESEARCH CORPORATION
 6801 SHINGLE CREEK PARKWAY
 MINNEAPOLIS, MINNESOTA 55430

PROPRIETARY NOTICE: THIS DRAWING CONTAINS PATENTED, PATENT PENDING, PATENT APPLIED FOR, AND/OR OTHER INFORMATION CONSIDERED PROPRIETARY BY AUDIO RESEARCH AND IS FURNISHED ON A CONFIDENTIAL BASIS FOR IDENTIFICATION PURPOSES ONLY.

BLK GRN WHT
 100-135 VAC 50/60Hz

PRODUCT: SP14

SP14

NOTES:

Schematic Symbol	Quantity	ARC Part#	Description
CAPACITORS			
C 1,2	4	53560103	CAP. 56 PFD +/-2% 630V DPN
C 3	2	53100101	CAP. 10 PF +/-1 PF 630V PPN
C 4	2	53150202	CAP. 150 PF 2 1/2% 630V PPN
C 5	2	53270101	CAP. 27 PFD +/-PFD 63V DPN
C 6,12	4	53500606	CAP. 5MF +/- 10% 250 V
C 7	2	53156400	CAP. .0156 MFD +/- 2% 630V
C 8	2	53480300	CAP. .0048 MFD +/- 2% 630V
C 9	2	53470510	CAP. .47 MFD 425V IAR
C 11	2	53200003	CAP. 2 PFD STYRENE
C 13	1	50100802	CAP. 100 MFD 450V
C 14,15,16,19	4	53220507	CAP. .22 MF 10% 160V
C 17,28,29,30,32,33,34	10	53100406	CAP. .01 MFD +/- 10% 630 V
C 18,20	2	53200602	CAP. 2 MFD +/-10% 450V
C 21	1	50150904	CAP. 1500 MFD 35V
C 22,23	2	53220506	CAP. .22 MFD 100V
C 24	1	51330702	CAP. 33 MFD +/- 10% 16V
C 25,26	2	53100407	CAP. .01MFD 250V 20% MPE MALL
C 27	2	52100300	CAP. 1000 PF 20% 1000V
C 31	1	53100608	CAP. 1.0 MFD 1-20% 425V TYPE V
C 35	2	52680000	CAP. 6.8PF +/- 1/2PF 1000 V
C 36	2	53560201	CAP. 560 PFD +/-2 1/2% 630 V
DIODES			
D 1,2,3,4	4	30502200	IN4006
D 5,6,7,8	4	30500400	IN4005 GENERAL INSTRUMENT
D 9,10,11,12,13,14,15,15A,15B,15C,16	24	30500910	FAIRCHILD IN916B
FUSES			
F1 (100/120V)	1	34500260	FUSE, BUSSMANN MDQ 3/4
F1 (220/240V)	1	34500104	.4 AMP MDQ
PANEL INDICATOR			
LE 1	1	34300102	LED,COLLAR & RETAINING RING
TRANSISTORS			
Q 1,1A	4	30006524	FET, WHITE RED YELLOW
Q 2,13	4	30007006	FET, GRAY BLUE
Q 3,5,10	6	30006702	FET, ORANGE RED
Q 4,6,8,8A,9,9A	12	30005901	FET, RED BROWN
Q 7	2	30006502	FET, WHITE RED
Q 11	1	30006811	FET, YELLOW
Q 12	1	30007102	FET, YELLOW RED
Q 13	2	30003100	TRANSIST., 2N5088, 2N5209, 2N5210
Q 14	2	30006723	FET, ORANGE RED ORANGE
RESISTORS			
R 6B.	2	42100503	RES. 100K +/-1% MK-3 50PPM
R 1,10	4	42549103	RES. 54.9 OHM 1% MK-3 50PPM
R 2	2	42499403	RES. 49.9K 1% MK-3 50PPM
R 2A	2	42100203	RES. 100 OHM 1% MK-3 50PPM
R 2B	2	42432103	RES. 43.2 OHM 1% MK-3 50PPM
R 2C,19,19A,19B,19C	10	42150203	RES. 150 OHM 1% MK-3 50PPM
R 2D,60,60A	6	42205203	RES. 205 OHM 1% MK-3 50PPM
R 2E,6,6A	6	42100403	RES. 10K +/-1% MK-3 50PPM
R 2F,48,51	4	42100303	RES. 1K 1% MK-3 50PPM
R 2G	2	42432303	RES. 4.32K 1% MK-3 50PPM
R 5	2	42121303	RES. 1.21K 1% MK-3 50PPM
R 7,54A	4	42215403	RES. 21.5K 1% MK-3 50PPM
R 7A	2	42121403	RES. 12.1K 1% MK-350PPM
R 8	2	42150514	RES. 150K 1% MK-5 1W 50PPM
R 8,23	4	42750405	RES. 75K 1% MK-8 50PPM

PRODUCT: SP14

SP14

NOTES:

Schematic Symbol	Quantity	ARC Part#	Description
R 9,13,24,27	8	42274405	RES. 27.4K 1% MK-8 50PPM
R 9B	2	42825405	RES. 82.5K 1% MK-8 50PPM
R 11,64	4	42357203	RES. 357 OHM 1% MK-3 50PPM
R 12,62	4	42274103	RES. 27.4 OHM 1% MK-3 50PPM
R 14,26,26A	6	42150414	RES. 15K 1% MK-5 50PPM
R 15,20,28	6	42475503	RES. 475K 1% MK-3 50PPM
R 16,16B,18	6	42619203	RES. 619 OHM 1% MK-3 50PPM
R 17	2	42562513	RES. 562K 1% MK-4 50PPM
R 18A	2	42274403	RES. 27.4K 1% MK-3 50PPM
R 18B	2	42357403	RES. 35.7K 1% MK-3 50PPM
R 21,29	4	42200205	RES. 200 OHM +/-1% MK8 50PPM
R 22,22A	4	42681303	RES. 6.81K 1% MK-3 50PPM
R 24A,24B,27A,35,36,42,43	10	42100505	RES. 100 1% MK-8 50PPM
R 25	2	42332103	RES. 33.2 OHM 1% MK-3 50PPM
R 25A,40,46B	4	42332203	RES. 332 OHM 1% MK-3 50PPM
R 26B,26C	4	42348403	RES. 34.8K 1% MK-3 50PPM
R 30,61	4	42681405	RES. 68.1K 1% MK-8 50PPM
R 31,31A,31B	6	42182303	RES. 1.82K 1% MK-3 50PPM
R 31C	2	42150303	RES. 1.50K 1% MK-3 50PPM
R 32	1	43100202	RES. 100 OHM 2W 5%
R 33	1	42158513	RES. 158K 1% MK-4 50PPM
R 34,34A,48A	3	42392403	RES. 39.2K 1% MK-3 50PPM
R 37	1	42499303	RES. 4.99K 1% MK-3 50PPM
R 38,63	3	42150403	RES. 15K 1% MK-3 50PPM
R 38A	1	42215503	RES. 215K 1% MK-3 50PPM
R 39	1	42280513	RES. 280K 1% MK-4 50PPM
R 41	1	43100002	RES. 1 OHM 2W 5% W.W.
R 44,45	2	42100703	RES. 10 MEG 1% MK-3 50PPM
R 46	1	43500100	RES. 50 OHM +/-5% 4 1/2W
R 46A	1	43750102	RES. 75 OHM 3W 5%
R 47	1	42768403	RES. 76.8K 1% MK-3 50PPM
R 48B	2	42162503	RES. 162K 1% MK-3 50PPM
R 49	1	42100603	RES. 1 MEG 1% MK-3 50PPM
R 50	1	41100702	RES. 10 MEG 1/4W 5%
R 52	1	42511303	RES. 5.11K 1% MK-3 50PPM
R 53	2	42255403	RES. 25.5K 1% MK-3 50PPM
R 53A,55A	4	42127403	RES. 12.7K 1% MK-3 50PPM
R 54	2	42118403	RES. 11.8K 1% MK-3 50PPM
R 55	2	42536303	RES. 5.36K 1% MK-3 50PPM
R 56,58,59	6	42464303	RES. 4.64K 1% MK-3 50PPM
R 56A	2	42316303	RES. 3.16K 1% MK-3 50PPM
R 57	2	42100314	RES. 1K 1% MK-5 50PPM
R 59A	2	42221303	RES. 2.2K 1% MK-3 50PPM
R 64A	2	42475203	RES. 475 OHM 1% MK-3 50PPM
CONTROLS			
RV 1	1	45100528	100K DUAL GAIN POT
RV 2	1	45100529	100 K DUAL BALANCE POT
RELAYS			
RY 1	2	64101000	RELAY, 12V REED 51P 1200 OHM
SWITCHES			
SW 1,12	2	24100710	TOGGLE SW., PREM. SILVER, PRE AM
SW 2,3,4,8,9,10	6	24100410	TOGGLE SW., PREM. GOLD, PRE AMP
SW 5	1	24002100	SWITCH, 5 POS. MODE
SW 6,7,11	3	24002000	SWITCH, 5 POS. ROTARY
TRANSFORMERS			
T 1	1	60007701	XFR. SP9(220/240V) TOROID
INTEGRATED CIRCUITS			
U 1	1	31002200	MC 34071 P MOTOROLA
U 2,3	2	31000801	SP10 TIMER MC1455PI

PARTS LIST

As of JAN 24 89

PRODUCT: SP14 SP14

NOTES:

Schematic Symbol	Quantity	ARC Part#	Description
U 4	1	31001900	TL071CP
U 5	1	31002000	D70/D115/D250 MC7815CT
VACUUM TUBES			
V 1	1	32001110	VAC.TUBE, 6DJ8 RUSSIAN
ZENER DIODES			
ZD 1	2	30504400	IN 5240B
ZD 2	2	30501800	IN5245B
ZD 3	1	30504200	IN5535A
ZD 4	1	30500300	IN 4740A
ZD 5,6	2	31000702	LM329DZ
ZD 7	1	30503500	IN5359 B
ZD 8,9,10	3	30503700	DIODE, Z20 10%