



TRUE MANUFACTURING CO., INC.

2001 East Terra Lane • O'Fallon, Missouri 63366-4434 • (636)240-2400
 Fax (636)272-2408 • Toll Free (800)325-6152 • Intl Fax# (001)636-272-7546
 Parts Dept. (800)424-TRUE • Parts Dept. Fax# (636)272-9471 • www.truemfg.com

PROJECT NAME

LOCATION

ITEM #

QTY

AIA #

MODEL #

SIS #

Models TGM-DC-77-SC/SC-B-W TGM-DC-77-SC/SC-W-W TGM-DC-77-SC/SC-S-W TGM-DC-77-SC/SC-S-S

True Glass Merchandiser Curved Glass, Solid Colored End Refrigerator



FEATURES

- ▶ True's "dry" glass merchandisers combines efficient, high volume merchandising with an elegant curved glass front for sophisticated presentation of high end desserts and pastries.
- ▶ Cabinet is NSF/ANSI Standard 2 compliant to hold open food product.
- ▶ Two (2) rear sliding glass doors for back access.
- ▶ Exterior - powder coated FDA black rounded front and back, solid wood sides with aluminum cover and front panels. Color options available (upcharge may apply) - white or stainless.
- ▶ Interior - powder coated FDA white over CRS material. Color options available (upcharge may apply) - black or stainless.
- ▶ Three (3) tiered levels of adjustable wire cantilever shelves that match cabinet interior color. Chrome plated wire shelves standard on stainless units.
- ▶ Curved glass front is single pane tempered glass with extra large viewing area to maximize product presentation.
- ▶ LED interior lighting provides more even lighting throughout the cabinet. Safety shielded.

TGM-DC-77-SC/SC-B-W

STANDARD OPTIONS

Exterior Color	Black, White, or Stainless Steel
Interior Color	Black, White, or Stainless Steel
Solid Mirrored End (SM)	Solid Exterior Sides & Mirrored interior sides
Shelving	White, Black, Chrome, or Mezzanine

ROUGH-IN DATA

Specifications subject to change without notice.
 Chart dimensions rounded up to the nearest 1/8" (millimeters rounded up to next whole number).

Model	Rear Doors	Shelves	Cabinet Dimensions (inches) (mm)			Voltage	Amps	NEMA Config.	Cord Length (total ft.) (total m)	Crated Weight White/Black Model (lbs.) (kg)	Crated Weight Stainless Model (lbs.) (kg)
			W	D	H						
TGM-DC-77-SC/SC-Δ-Δ	2	6	77¼ 1962	39 990	49⅞ 1247	115/60/1	7.0	5-15P	9 2.74	TBD TBD	TBD TBD

Δ Represents Exterior/Interior (B-black, W-White, S-Stainless)

	APPROVALS:	AVAILABLE AT:
	10/18	Printed in U.S.A.

Models:	
TGM-DC-77-SC/SC-B-W	TGM-DC-77-SC/SC-W-W
TGM-DC-77-SC/SC-S-W	TGM-DC-77-SC/SC-S-S

True Glass Merchandiser:

Curved Glass, Solid Colored End Refrigerator



STANDARD FEATURES

DESIGN

- True's dry display case glass merchandiser combines efficient, high volume merchandising and exceptional refrigeration with an elegant curved glass front for sophisticated presentation of high end deli, desserts and pastries.
- Designed to provide an attractive companion to our TGM-R "refrigerated" glass merchandiser. Please note: If units are banked together, because of side panel, a 1/2" (13mm) gap will remain between units.

CABINET CONSTRUCTION

- Exterior - powder coated FDA black rounded front and back, solid wood sides with aluminum cover and front panels. Color options available (upcharge may apply) - white or stainless.
- Curved glass front and side glass panels.
- Interior - powder coated FDA white over CRS material. Color options available (upcharge may apply) - black or stainless.
- Insulation - entire cabinet structure is foamed-in-place using a high density, polyurethane insulation that has zero ozone depletion potential (ODP) and zero global warming potential (GWP).
- Welded, heavy duty steel frame rail, black powder coated for corrosion protection.
- Frame rail fitted with leg levelers.

CURVED FRONT DISPLAY GLASS

- Curved glass front is single pane tempered glass with extra large viewing area to maximize product presentation.

REAR DOORS

- Two (2) rear sliding glass doors for back access.

- Each door fitted with 12" (305 mm) long aluminum handle.
- Sliding doors ride on stainless steel V-channel with stainless steel bearings. Doors fit within plastic channel frame.

SHELVING

- Six (6) adjustable heavy duty PVC coated wire shelves standard.
- Each shelf supports a maximum weight of 150 lbs. (69 kg).

PAN CAPACITY

- Cabinet holds eight (8) 18"L x 26"D (458 mm x 661 mm) display pans and twelve (12) 12"L x 18"D (305 mm x 458 mm) display pans. Pans supplied by others.

LIGHTING

- LED interior lighting, two (2) clips underneath shelf to keep wires in place. Safety shielded.

MODEL FEATURES

- NSF/ANSI Standard 2 compliant for open food product.

ELECTRICAL

- Unit completely pre-wired at factory and ready for final connection to a 115/60/1 phase, 15 amp dedicated outlet. Cord and plug set included.



115/60/1
NEMA-5-15R

STANDARD OPTIONS

Upcharge and lead times may apply.

- Black exterior
- White exterior
- Stainless steel exterior
- White interior
- Black interior
- Stainless steel interior
- Solid Colored Exterior Sides with color matching interior (SC)
- Solid Colored Exterior Sides with Mirrored interior ends (SM)
- White wire shelves
- Black wire shelves
- Chrome plated wire shelves
- Stainless steel mezzanine shelves

OPTIONAL FEATURES/ACCESSORIES

Upcharge and lead times may apply.

- Custom exterior colors (contact factory for details)
- Glass shelves
- Frosted glass shelves
- Ratchet lock
- Electrical Receptacle
- Exterior top scale shelf
- Exterior small top service shelf
- Exterior medium top service shelf
- Exterior large top service shelf
- External front shelf kit (only available in black)
- External rear service shelf kit (only available in black)
- 4" (102mm) Castors
- 2 1/2" (64mm) castors
- 6" (153mm) legs

TGM MODEL NUMBER NOMENCLATURE SYSTEM

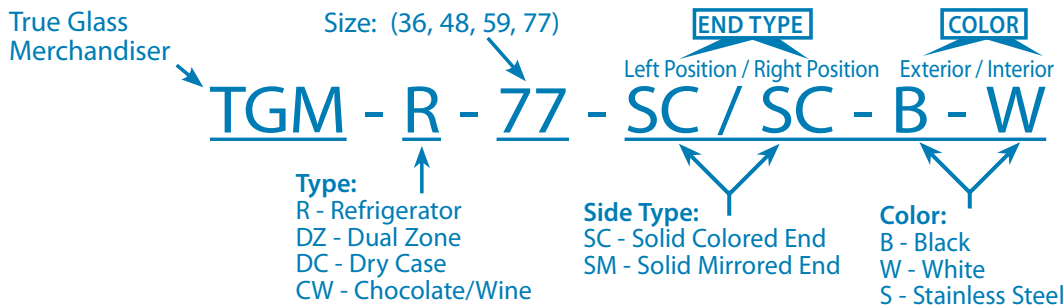

PLAN VIEW

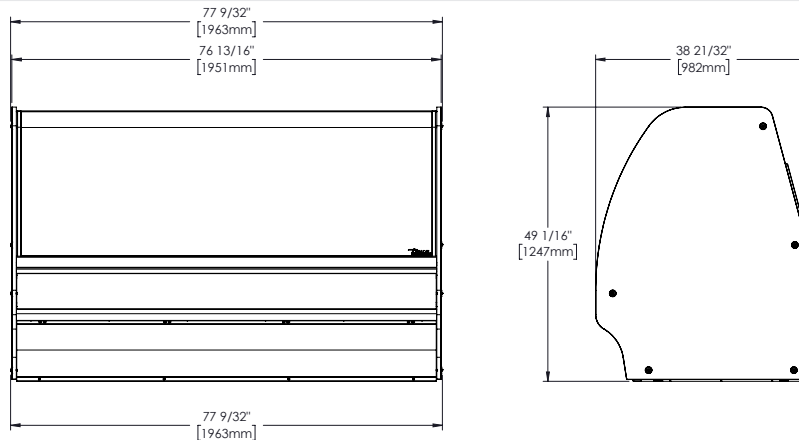

WARRANTY

Three year warranty on all parts and labor and an additional 2 year warranty on compressor. (U.S.A. only)

METRIC DIMENSIONS ROUNDED UP TO THE NEAREST WHOLE MILLIMETER

SPECIFICATIONS SUBJECT TO CHANGE WITHOUT NOTICE



Elevation	Right	Plan	3D	Back

TRUE MANUFACTURING CO., INC.

2001 East Terra Lane • O'Fallon, Missouri 63366-4434 • (636)240-2400 • Fax (636)272-2408 • Toll Free (800)325-6152 • Intl. Fax# (001)636-272-7546 • www.truefmfg.com