



TRUE MANUFACTURING CO., INC.

2001 East Terra Lane • O'Fallon, Missouri 63366-4434 • (636)240-2400
 Fax (636)272-2408 • Toll Free (800)325-6152 • Intl Fax# (001)636-272-7546
 Parts Dept. (800)424-TRUE • Parts Dept. Fax# (636)272-9471 • www.truemfg.com

PROJECT NAME

LOCATION

ITEM #

QTY

AIA #

MODEL #

SIS #

Models TDM-DZ-59-GE/GE-B-W TDM-DZ-59-GE/GE-W-W TDM-DZ-59-GE/GE-S-W TDM-DZ-59-GE/GE-S-S

True Display Merchandiser Curved Glass, Glass End Dual Zone



TDM-DZ-59-GE/GE-B-W



TDM-DZ-59-GE/GE-W-W

FEATURES

- ▶ True's refrigerated display merchandisers combine efficient, high volume merchandising and exceptional refrigeration with an elegant curved glass front for sophisticated presentation of high end desserts and pastries.
- ▶ Refrigerated section features factory engineered, self-contained, capillary tube system using environmentally friendly R290 hydro carbon refrigerant that has zero (0) ozone depletion potential (ODP), & three (3) global warming potential (GWP).
- ▶ Refrigerated section features high capacity, factory balanced refrigeration system. Standard temperature range maintains cabinet temperatures of 33°F to 41°F (.5°C to 5°C), ideally suited for refrigerated bakery and cold deli products.
- ▶ Cabinet is NSF/ANSI Standard 7 compliant to hold open food product.
- ▶ Two (2) rear sliding glass doors for back access.
- ▶ Exterior - powder coated FDA black rounded front and back, black aluminum aesthetic side and front panels. Color options available (upcharge may apply) - white or stainless. Curved glass front and side glass panels.
- ▶ Interior - powder coated FDA white over CRS material. Color options available (upcharge may apply) - black or stainless.
- ▶ Six (6) tiered levels of adjustable wire cantilever shelves that match cabinet interior color. Chrome plated wire shelves standard on stainless units.
- ▶ Front glass swings Up for easy cleaning access.
- ▶ LED interior lighting provides more even lighting throughout the cabinet. Safety shielded.

STANDARD OPTIONS

Exterior Color	Black, White, or Stainless Steel
Interior Color	Black, White, or Stainless Steel
Glass End (GE)	Clear Glass Interior/Clear Glass Exterior with Black Trim
Mirrored End (ME)	Mirrored Glass Interior/Black Glass Exterior
Solid Mirrored End (SM)	Mirrored Glass Interior/Solid Metal Exterior - must indicate finish on SM Black, White, or Stainless
Shelving	White, Black, Chrome, or Mezzanine

ROUGH-IN DATA

Specifications subject to change without notice. Chart dimensions rounded up to the nearest 1/8" (millimeters rounded up to next whole number).

Model	Doors	Shelves	Cabinet Dimensions (inches) (mm)			HP	Voltage	Amps	NEMA Config.	Cord Length (total ft.) (total m)	Crated Weight White/Black Model (lbs.) (kg)	Crated Weight Stainless Model (lbs.) (kg)
			W	D	H							
TDM-DZ-59-GE/GE-Δ-Δ	2	6	59 1/4 1505	39 991	49 3/8 1248	1/4 1/4	115/60/1 230-240/50/1	10.0 1.8	5-15P ▲	8 2.44	770 350	TBD TBD

Δ Represents Exterior/Interior (B-black, W-White, S-Stainless)

▲ Plug type varies by country.



APPROVALS:

AVAILABLE AT:

Models:	
TDM-DZ-59-GE/GE-B-W	TDM-DZ-59-GE/GE-W-W
TDM-DZ-59-GE/GE-S-W	TDM-DZ-59-GE/GE-S-S

True Display Merchandiser: Curved Glass, Glass End Dual Zone



STANDARD FEATURES

DESIGN

- True's combination "refrigerated" and "dry" display case combines efficient, high volume merchandising and exceptional refrigeration with an elegant curved glass front for sophisticated presentation of high end deli, desserts and pastries.
- Please note: If units are banked together, because of side panel, a 1/2" gap will remain between units.

REFRIGERATION SYSTEM

- Factory engineered, self-contained, capillary tube system using environmentally friendly R290 hydrocarbon refrigerant that has zero (0) ozone depletion potential (ODP), & three (3) global warming potential (GWP).
- Exclusive reversing condenser fan motors. Fan motors reverse during defrost off cycles to help keep condenser coil free from dirt, dust and debris. Keeping coils clean optimizes the unit's performance providing colder holding temperatures and increased energy efficiency. Regularly scheduled thorough cleaning of coils still recommended.
- High capacity, factory balanced refrigeration system that has two (2) temperature range options in refrigerated section. Standard temperature range maintains cabinet temperatures of 33°F to 41°F (5°C to 5°C), ideally suited for refrigerated bakery and cold deli products. Optional temperature range maintains cabinet temperatures of 42°F to 65°F (5.5°C to 18.3°C), ideally suited for chocolate & wine options.
- Pull Out Condensing unit slides out for easy cleaning and maintenance.

CABINET CONSTRUCTION

- Exterior - powder coated FDA black rounded front and back, black aluminum aesthetic side and front panels. Color options available (upcharge may apply) - white or stainless.

- Curved glass front and side glass panels.
- Interior - powder coated FDA white over CRS material. Color options available (upcharge may apply) - black or stainless.
- Insulation - entire cabinet structure is foamed-in-place using a high density, polyurethane insulation that has zero ozone depletion potential (ODP) and zero global warming potential (GWP).
- Welded, heavy duty steel frame rail, black powder coated for corrosion protection.
- Frame rail fitted with leg levelers.

CURVED FRONT DISPLAY GLASS

- Curved glass front and side panels are single pane tempered glass. Front glass opens from closed to fully open to provide extra large viewing area to maximize product presentation while allowing full frontal access.

REAR DOORS

- Two (2) rear sliding glass doors for back access.
- Each door fitted with 12" (305 mm) long aluminum handle.
- Sliding doors ride on stainless steel V-channel with stainless steel bearings. Doors fit within plastic channel frame.

SHELVING

- Six (6) adjustable heavy duty PVC coated wire shelves standard.
- Each shelf supports a maximum weight of 150 lbs. (69 kg).

PAN CAPACITY

- Cabinet holds eight (8) 18"L x 26"D (458 mm x 661 mm) display pans and four (4) 9"L x 26"D (229 mm x 661 mm) display pans. Pans supplied by others.

LIGHTING

- LED interior lighting, two (2) clips underneath shelf to keep wires in place. Safety shielded.

MODEL FEATURES

- Refrigerator evaporator is epoxy coated to eliminate the potential of corrosion.
- Front glass swings Up for easy cleaning access.
- Pull out condensing unit slides out for easy cleaning and maintenance.
- Electronic temperature control.
- NSF/ANSI Standard 7 compliant for open food product. Tested and certified for performance at NSF Type II: 80°F (27°C) and 55% relative humidity.

ELECTRICAL

- Unit completely pre-wired at factory and ready for final connection to a 115/60/1 phase, 15 amp dedicated outlet. Cord and plug set included.



115/60/1
NEMA-5-15R

OPTIONAL FEATURES/ACCESSORIES

Upcharge and lead times may apply.

- 230 - 240V / 50 Hz.
- White exterior
- Stainless steel exterior
- Custom exterior colors (contact factory for details)
- Black interior
- Stainless steel interior
- Mirrored interior ends with black glass exterior (ME)
- Mirrored interior ends with Solid metal exterior (SM)
- Black wire shelves
- Chrome plated wire shelves
- Stainless mezzanine shelves

TDM MODEL NUMBER NOMENCLATURE SYSTEM

True Display Merchandiser

Size: (36, 48, 59, 77)

END TYPE

COLOR

Left Position / Right Position

Exterior / Interior

TDM - R - 77 - GE / GE - B - W

Type:
R - Refrigerator
DZ - Dual Zone
DC - Dry Case
CW - Chocolate/Wine

Side Type:
GE - Glass End
ME - Mirrored End
SM - Solid Mirrored End

Color:
B - Black
W - White
S - Stainless Steel

End Types Pictured Below



GE

(Stainless Exterior)



ME

(Stainless Exterior)



SM

(Stainless Exterior)

PLAN VIEW

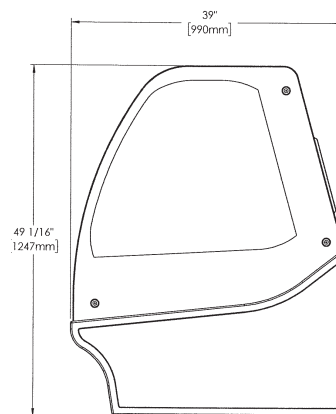
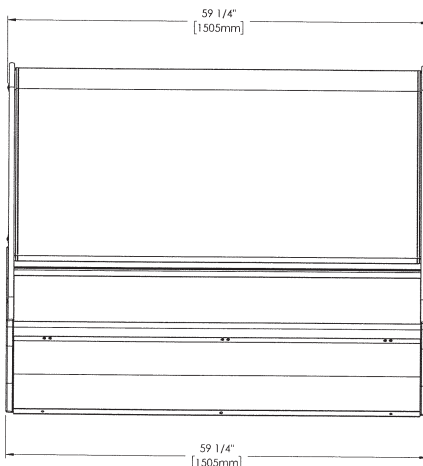

WARRANTY

Three year warranty on all parts and labor and an additional 2 year warranty on compressor. (U.S.A. only)

METRIC DIMENSIONS ROUNDED UP TO THE NEAREST WHOLE MILLIMETER

SPECIFICATIONS SUBJECT TO CHANGE WITHOUT NOTICE



Elevation	Right	Plan	3D	Back

TRUE MANUFACTURING CO., INC.

2001 East Terra Lane • O'Fallon, Missouri 63366-4434 • (636)240-2400 • Fax (636)272-2408 • Toll Free (800)325-6152 • Intl. Fax# (001)636-272-7546 • www.truefmfg.com