



**TRUE FOOD SERVICE EQUIPMENT, INC.**

2001 East Terra Lane • O'Fallon, Missouri 63366-4434 • (636)240-2400  
 Fax (636)272-2408 • Toll Free (800)325-6152 • Intl Fax# (001)636-272-7546  
 Parts Dept. (800)424-TRUE • Parts Dept. Fax# (636)272-9471 • www.truemfg.com

Project Name: \_\_\_\_\_

Location: \_\_\_\_\_

Item #: \_\_\_\_\_ Qty: \_\_\_\_\_

Model #: \_\_\_\_\_

A/A #

SIS #

Model:

**TBB-24GAL-72G-S-HC-LD**

**Underbar Refrigeration:**

*Glass Swing Door Galvanized Top Stainless Steel 24" Back Bar Cooler with LED Lighting & Hydrocarbon Refrigerant*

**TBB-24GAL-72G-S-HC-LD**

- ▶ True's refrigerated back bar coolers are designed with enduring quality and value. Our commitment to using the highest quality materials and oversized refrigeration assures colder product temperatures and years of trouble free service.
- ▶ Oversized, factory balanced, refrigeration system holds 33°F to 38°F (.5°C to 3.3°C).
- ▶ Exterior - stainless steel front and sides. Matching aluminum back. Galvanized steel top designed to slide under existing cabinetry.
- ▶ Interior - Stainless steel floor with ½" (13 mm) reinforced lip and heavy gauge galvanized steel walls.
- ▶ NSF/ANSI Standard 7 compliant for packaged and bottled product.
- ▶ Positive seal doors.
- ▶ "Low-E", double pane thermal glass door assemblies with extruded aluminum frames. The latest in energy efficient technology.
- ▶ LED interior lighting provides more even lighting throughout the cabinet. Safety shielded.
- ▶ Entire cabinet structure is foamed-in-place using a high density, polyurethane insulation that has zero ozone depletion potential (ODP) and zero global warming potential (GWP).



**ROUGH-IN DATA**

Specifications subject to change without notice.  
 Chart dimensions rounded up to the nearest 1/8" (millimeters rounded up to next whole number).

Model	Doors	Capacity		Shelves	Cabinet Dimensions (inches) (mm)			HP	Voltage	Amps	NEMA Config.	Cord Length (total ft.) (total m)	Crated Weight (lbs.) (kg)
		12 oz. Cans	½ Barrels		L	D†	H						
TBB-24GAL-72G-S-HC-LD	3	84 6-pks	3**	6	71 7/8 1826	24 1/4 616	34 1/4 870	1/4 N/A	115/60/1	2.7 N/A	5-15P	7 2.13	435 198

† Depth does not include 1 3/8" (35 mm) for door handles and 1" (26 mm) for rear bumpers.



APPROVALS:

AVAILABLE AT:

Model:  
TBB-24GAL-72G-S-HC-LD

## Underbar Refrigeration:

Glass Swing Door Galvanized Top Stainless Steel 24" Back Bar Cooler with LED Lighting & Hydrocarbon Refrigerant



### STANDARD FEATURES

#### DESIGN

- True's refrigerated back bar coolers are designed with enduring quality and value. Our commitment to using the highest quality materials and oversized refrigeration assures colder product temperatures and years of trouble free service.

#### REFRIGERATION SYSTEM

- Factory engineered, self-contained, capillary tube system using environmentally friendly R290 hydrocarbon refrigerant that has zero (0) ozone depletion potential (ODP), & three (3) global warming potential (GWP).
- High capacity, factory balanced refrigeration system that maintains cabinet temperatures of 33°F to 38°F (.5°C to 3.3°C) for the best in food preservation.
- State of the art, electronically commutated evaporator and condenser fan motors. ECM motors operate at higher peak efficiencies and move a more consistent volume of air which produces less heat, reduces energy consumption and provides greater motor reliability.
- Condensing unit accessed from behind front grill, slides out for easy cleaning and maintenance.

#### CABINET CONSTRUCTION

- Exterior - stainless steel front and sides. Matching aluminum back. Galvanized steel top designed to slide under existing cabinetry.

- Interior - Stainless steel floor with ½" (13 mm) reinforced lip and heavy gauge galvanized steel walls.
- Door threshold protector prevents damage to cabinet from routine loading of product.
- Insulation - entire cabinet structure is foamed-in-place using a high density, polyurethane insulation that has zero ozone depletion potential (ODP) and zero global warming potential (GWP).
- Welded, heavy duty steel frame rail, black powder coated for corrosion protection.

#### DOORS

- "Low-E", double pane thermal insulated glass door assemblies with extruded aluminum frames. The latest in energy efficient technology.
- Each door fitted with 12" (305 mm) long handle.
- Positive seal doors.
- Magnetic door gaskets of one piece construction, removable without tools for ease of cleaning.
- Door locks standard.

#### SHELVING

- Six (6) adjustable, heavy duty, black PVC coated wire shelves. Two (2) right and two (2) left shelf dimensions are 19"L x 16 ¼"D (483 mm x 413 mm). Two (2) center door shelf dimensions are 19 ½"L x 16 ¼"D (499 mm x 413 mm). Four (4) chrome plated shelf clips included per shelf.
- Aluminum shelf support pilasters. Shelves are adjustable on ½" (13 mm) increments.

#### LIGHTING

- LED interior lighting provides more even lighting throughout the cabinet. Safety shielded.

#### MODEL FEATURES

- Evaporator is epoxy coated to eliminate the potential of corrosion.
- Designed to accommodate a variety of beer kegs. Depending on tapping kit used, ½ barrels may not fit.
- NSF/ANSI Standard 7 compliant for the storage and/or display of packaged or bottled product.

#### ELECTRICAL

- Unit completely pre-wired at factory and ready for final connection to a 115/60/1 phase, 15 amp dedicated outlet. Cord and plug set included.



115/60/1  
NEMA-5-15R

#### OPTIONAL FEATURES/ACCESSORIES

Upcharge and lead times may apply.

- 6" (153 mm) standard legs.
- 6" (153 mm) seismic/flanged legs.
- 2 ½" (64 mm) diameter castors.
- 4" (102 mm) diameter castors.
- Additional shelves.

### PLAN VIEW

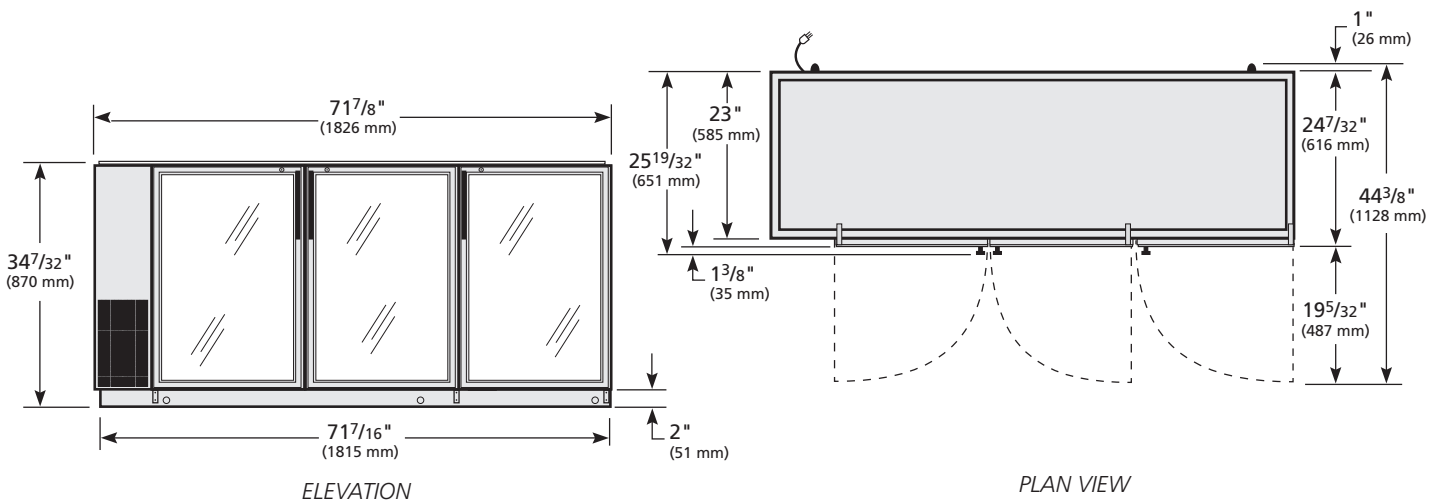

**WARRANTY\***  
Three year warranty on all parts and labor and an additional 2 year warranty on compressor. (U.S.A. only)

METRIC DIMENSIONS ROUNDED UP TO THE NEAREST WHOLE MILLIMETER

SPECIFICATIONS SUBJECT TO CHANGE WITHOUT NOTICE



Model	Elevation	Right	Plan	3D	Back
TBB-24GAL-72G-S-HC-LD	TFJX66E	TFJX66S	TFJX66P	TFJX663	

\*RESIDENTIAL APPLICATIONS: True assumes no liability for parts or labor coverage for component failure, factory defect or any other damages for units installed in non-commercial foodservice or residential applications.

### TRUE FOOD SERVICE EQUIPMENT