



TRUE MANUFACTURING CO., INC.
U.S.A. FOODSERVICE DIVISION

2001 East Terra Lane • O'Fallon, Missouri 63366-4434 • (636)240-2400
 Fax (636)272-2408 • Toll Free (800)325-6152 • Intl Fax# (001)636-272-7546
 Parts Dept. (800)424-TRUE • Parts Dept. Fax# (636)272-9471 • www.truemfg.com

Project Name: _____	A/A #
Location: _____	S/S #
Item #: _____ Qty: _____	
Model #: _____	

Model:
TAC-72-LD

Vertical Air Curtains:
Refrigerator with LED Lighting



TAC-72-LD

- ▶ True's air curtain merchandisers are designed with enduring quality that protects your long term investment.
- ▶ Designed using the highest quality materials and components to provide the user with colder product temperatures and lower utility costs in an attractive merchandiser that brilliantly displays food and beverages.
- ▶ Large, open front allows easy access to display levels and places maximum attention on merchandising.
- ▶ Oversized, factory balanced, refrigeration system holds 35°F to 40°F (1.6°C to 4.4°C).
- ▶ Patented reversing condenser fan motors. Fan motors reverse during defrost off cycles to help keep condenser coil free from dirt, dust and debris. Keeping coils clean optimizes the unit's performance providing colder holding temperatures and increased energy efficiency. Regularly scheduled thorough cleaning of coils still recommended.
- ▶ Durable and permanent non-peel or chip white vinyl exterior with white aluminum interior and stainless steel floor and deck pans.
- ▶ Adjustable, heavy duty, cantilevered, shelves.
- ▶ Entire cabinet structure is foamed-in-place using Ecomate. A high density, polyurethane insulation that has zero ozone depletion potential (ODP) and zero global warming potential (GWP).

Exterior Color Options



ROUGH-IN DATA

Specifications subject to change without notice.
 Chart dimensions rounded up to the nearest 1/8" (millimeters rounded up to next whole number).

Model	Shelves	Cabinet Dimensions (inches) (mm)			HP	Voltage	Amps	NEMA Config.	Cord Length (total ft.) (total m)	Crated Weight (lbs.) (kg)
		L	D	H						
TAC-72-LD	8	72 1829	29 1/4 743	81 7/8 2080	3/4 N/A	208/230/60/1	12.5 N/A	6-20P	6.5 1.98	805 366

Requires 208-230/60 Hz, single phase, NEMA 6-20R.

	APPROVALS:	AVAILABLE AT:
	5/18	Printed in U.S.A.

Model:
TAC-72-LD

Vertical Air Curtains: Refrigerator with LED Lighting



STANDARD FEATURES

DESIGN

- Designed using the highest quality materials and components to provide the user with colder product temperatures and lower utility costs in an attractive merchandiser that brilliantly displays packaged food and beverages.

REFRIGERATION SYSTEM

- Factory engineered, self-contained, capillary tube system using environmentally friendly (CFC free) R404A refrigerant.
- Time-initiated, time-terminated off cycle defrost system.
- Extra large evaporator coil and condensers balanced with higher horsepower compressor; maintains cabinet temperatures of 35°F to 40°F (1.6°C to 4.4°C) for the best in food preservation.
- Sealed, cast iron, self-lubricating evaporator fan motors.
- Bottom mounted condensing units positioned for easy maintenance.
- Patented reversing condenser fan motors. Fan motors reverse during defrost off cycles to help keep condenser coil free from dirt, dust and debris. Keeping coils clean optimizes the unit's performance providing colder holding temperatures and increased energy efficiency. Regularly scheduled thorough cleaning of coils still recommended.

CABINET CONSTRUCTION

- Exterior - durable and permanent non-peel or chip white vinyl front and sides with matching white aluminum back.
- Plexiglass lower front panel; durable and break resistant.
- Interior - attractive, NSF approved, white aluminum liner. Stainless steel interior floor and deck pans.

- Insulation - entire cabinet structure is foamed-in-place using a high density, polyurethane insulation that has zero ozone depletion potential (ODP) and zero global warming potential (GWP).
- Welded, heavy duty steel frame rail, black powder coated for corrosion protection.
- Frame rail fitted with leg levelers.
- Illuminated exterior sign panel. Variety of sign options available.

SHELVING

- Eight (8) adjustable, white, heavy duty, cantilevered shelves 33 1/4" L x 17" D (845 mm x 432 mm).
- Shelf support pilasters made of stainless steel; shelves are adjustable on 1" (26 mm) increments.

LIGHTING

- LED interior lighting provides more even lighting throughout the cabinet. Safety shielded.

MODEL FEATURES

- Perforated interior back wall for more efficient airflow.
- Listed under NSF/ANSI Standard 7 for the storage and/or display of packaged or bottled product.

ELECTRICAL

- Unit completely pre-wired at factory and ready for final connection to a 208-230V / 60 Hz single phase, 20 amp dedicated outlet.
- Unit utilizes a dual compressor system rated at 3/4 HP each.
- Cord and plug set included.



208-230/60/1
NEMA-6-20R

RECOMMENDED OPERATING CONDITIONS

- Designed to operate in an environment where temperature and humidity do not exceed 75°F (24°C) and 55% relative humidity.

- Unit should not be installed near HVAC vents, fans or doorways that will disrupt the air curtain and compromise the function of the cabinet. Unit should not be installed in direct sunlight.
- Model will run most efficiently when completely loaded with product.
- Drain plumbing hookup recommended.
- Please be advised Air Curtain models are substantially louder than standard refrigeration models.

OPTIONAL FEATURES/ACCESSORIES

Upcharge and lead times may apply.

- 4" (102 mm) diameter castors (set of 6).
- 5" (127 mm) diameter castors (set of 6).
- Variety of sign panels - see our website for the latest color and sign offerings.
- Black exterior.
- Stainless steel exterior.
- Black interior liner with black shelves.
- White cantilevered shelves.
- Stainless steel cantilevered shelves. Require two shelves per level.
- Night cover.
- Vandal panel.
- White locking security cover. Standard with flat sign panel. Adds 6 3/4" (171 mm) to cabinet height. (Factory Installed with some Field assembly required.)
- Silver locking security cover. Standard with flat sign panel. Adds 6 3/4" (171 mm) to cabinet height. (Factory Installed with some Field assembly required.)
- Black/bronze locking security cover. Standard with flat sign panel. Adds 6 3/4" (171 mm) to cabinet height. (Factory Installed with some Field assembly required.)

PLAN VIEW

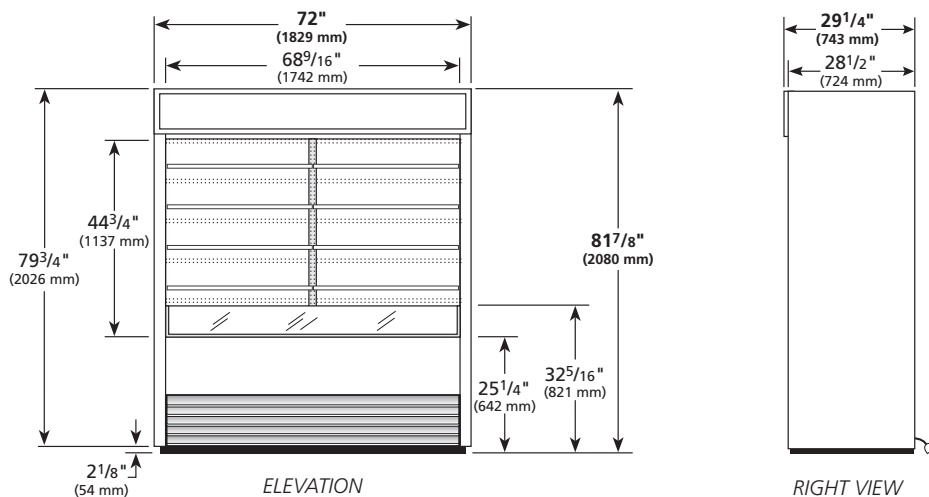

WARRANTY

Three year warranty on all parts and labor and an additional 2 year warranty on compressor. (U.S.A. only)

METRIC DIMENSIONS ROUNDED UP TO THE NEAREST WHOLE MILLIMETER

SPECIFICATIONS SUBJECT TO CHANGE WITHOUT NOTICE



Model	Elevation	Right	Plan	3D	Back
TAC-72-LD	TFDX029E	TFDX029S	TFDX030P	TFDX0303	

TRUE MANUFACTURING CO., INC.

2001 East Terra Lane • O'Fallon, Missouri 63366-4434 • (636)240-2400 • Fax (636)272-2408 • Toll Free (800)325-6152 • Intl. Fax# (001)636-272-7546 • www.truefmfg.com