

HOBART701 S Ridge Avenue, Troy, OH 45374
1-888-4HOBART • www.hobartcorp.com**LXe
HOT AND COLD****HOBART****STANDARD FEATURES**

- 32 racks per hour – LXeH
- 34 racks per hour – LXeC
- .74 gallons of water per rack
- Hot water or chemical sanitation units available
- Low chemical alert indicators
- Sense-A-Temp™ booster heater capable of 70° rise, provided on LXeH models
- Delime notification with cycle
- Chemical pump “auto-prime”
- Service diagnostics
- Deep drawn stainless steel tank
- Microcomputer, top mounted controls with digital cycle/temperature display
- Revolving upper and lower anti-clogging wash arms
- Revolving upper and lower rinse arms
- Removable stainless steel scrap screen
- Corrosion resistant pump
- Automatic pumped drain
- 17" door opening
- Automatic fill
- Detergent and rinse aid pumps standard (plus sanitizer pump on chemical machine)
- Electric tank heat
- Two dishracks – one peg and one combination type

STANDARD VOLTAGES

- 120/208-240(3W)/60/1 (LXeH model only)
- 120/60/1 (LXeC model only)

OPTIONS AT EXTRA COST

- 208-240(2W)/60/1 (LXeH model only)
- 208-240/60/3 (LXeH model only)

MODELS

- LXeC
- LXeH

ACCESSORIES

- Power cord kits
- Stainless steel base with 6" legs
- 17" stainless steel stand with storage
- External caster kit
- DWT-LXe drain water tempering kit

Specifications, Details and Dimensions on Back.

**LXe HOT AND COLD**

NOTICE

Required flowing water pressure to the dishmachine is 15-65 PSIG. If pressures higher than 65 PSIG are present, a pressure regulating valve must be installed in the water line to the dishmachine (by others). Pressure gauge not required on pumped rinse machines.

Important: The chemical containers should be placed no higher than 10" above floor.

If chemical containers are to be placed in cabinet adjacent to machine, a 1/2" dia. hole is required in the cabinet to run chemical supply line.

Notes:

- All vertical machine dimensions taken from floor may be increased by 1".
- Moist air escapes from the door. Use only moisture resistant materials adjacent to dishmachine sides and top.
- A vent hood is not recommended above the undercounter dishmachine since it does not produce excessive vapors.

Plumbing notes:

- Water hammer arrestor (meeting ASSE-1010 Standard or equivalent) to be supplied (by others) in common water supply line at service connection.
- Recommended water hardness to be 3 grains or less for best results.
- If drain hose is looped above a sink, the loop must not exceed 38" AFF.

CONNECTION INFORMATION (AFF = ABOVE FINISHED FLOOR)

LEGEND

- E1 ELECTRICAL CONNECTION: 1-3/8" DIA. HOLE FOR 1" TRADE SIZE CONDUIT; 4-5/8" AFF.
- P1 SINGLE FILL AND RINSE CONNECTION: 3/4" FEMALE GARDEN HOSE FITTING ON 6' LONG HOSE SUPPLIED WITH MACHINE.; 110°F WATER MIN FOR LXeH
- P2 DRAIN CONNECTION: 5/8" BARB FITTING WITH 6' LONG HOSE SUPPLIED WITH MACHINE.

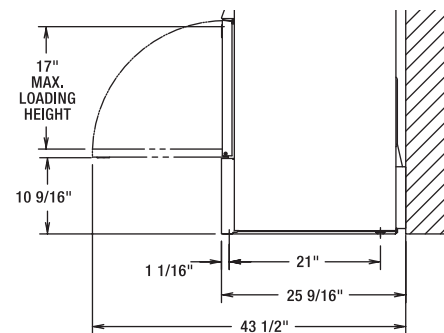
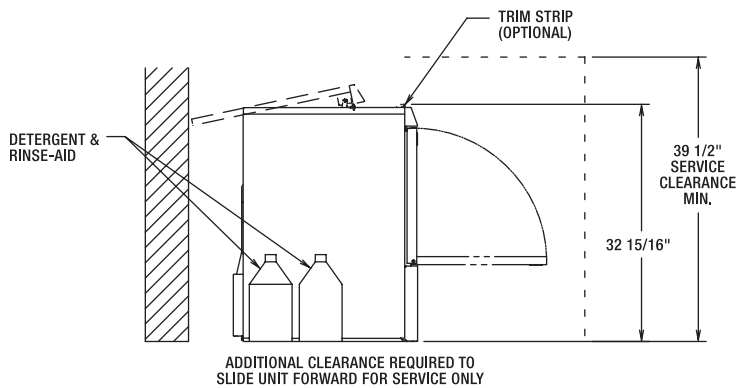
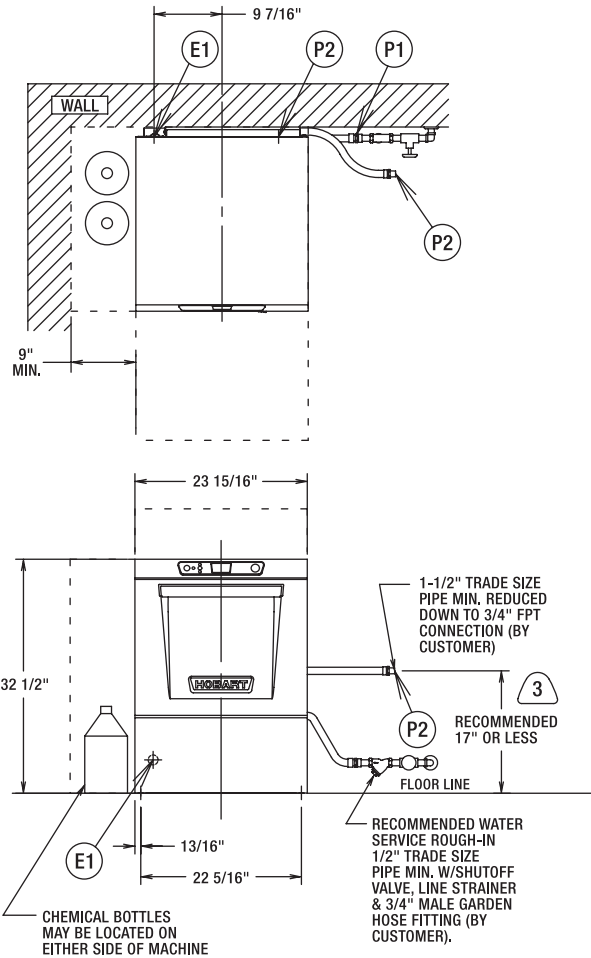

HEAT OUTPUT, BTU/HR		
MODEL	LATENT	SENSIBLE
LXeH	4600	4000

SHIPPING WEIGHTS		LXeH
NET WEIGHT OF MACHINE		150 LBS
DOMESTIC SHIPPING WEIGHT		170 LBS

MODEL	VOLTS/HERTZ/PHASE	RATED AMPS	MIN SUPPLY CKT CONDUCTOR AMPACITY	MAX PROTECTIVE DEVICE
LXeH	208-240/60/1	30.5	40	40
	120/208-240(3W)/60/1*	30.5	40	40
	120/208(3W)/60/1**	20.9	30	30
	208-240/60/3	23.9	30	30
	220-240/50/1	30.5	40	40

NOTE: FOR SUPPLY CONNECTIONS, USE COPPER WIRE ONLY RATED AT 90°C MINIMUM.
* THIS SYSTEM REQUIRES THREE POWER WIRES WHICH INCLUDES A CURRENT CARRYING NEUTRAL, AN ADDITIONAL FOURTH WIRE MUST BE PROVIDED FOR MACHINE GROUND.
** ORDER MODEL LXEH-30 (BOOSTER AND TANK HEATER NOT ENERGIZED CONCURRENTLY).
ACCESSORY CORD KIT AVAILABLE FOR ALL MACHINES

⚠ WARNING

Electrical and grounding connections must comply with the applicable portions of the National Electrical Code and/or other local electrical codes.

Plumbing connections must comply with applicable sanitary, safety and plumbing codes. Drain and fill line configurations vary, some methods are shown on this drawing.

MODELS:
LXeH
00-947871
REV C



701 S Ridge Avenue, Troy, OH 45374
1-888-4HOBART • www.hobartcorp.com

**LXeC
COLD**

⚠ WARNING

**Do not premix other chemicals and sodium hypochlorite (liquid bleach).
Mixing may cause hazardous gas to form.**

NOTICE

Required flowing water pressure to the dishmachine is 15-65 PSIG. If pressures higher than 65 PSIG are present, a pressure regulating valve must be installed in the water line to the dishmachine (by others). Pressure gauge not required on pumped rinse machines.

Important: Chemical containers should be placed no higher than 10" above floor.

If chemical containers are to be placed in cabinet adjacent to machine, a 1/2" dia. hole is required in the cabinet to run chemical supply line.

Use only 6% or 8.4% sodium hypochlorite (liquid bleach) as sanitizing chemical to insure proper operation of dishmachine.

Certain materials including silver plate, aluminum and pewter are attacked by sodium hypochlorite (liquid bleach). See instructional manual.

Notes:

- All vertical machine dimensions taken from floor may be increased by 1".
- Moist air escapes from the door. Use only moisture resistant materials adjacent to dishmachine sides and top.
- A vent hood is not recommended above the undercounter dishmachine since it does not produce excessive vapors.

Plumbing notes:

- Water hammer arrestor (meeting ASSE-1010 Standard or equivalent) to be supplied (by others) in common water supply line at service connection.
- Recommended water hardness to be 3 grains or less for best results.
- If drain hose is looped above a sink, the loop must not exceed 38" AFF.

**CONNECTION INFORMATION
(AFF = ABOVE FINISHED FLOOR)**

LEGEND

- E1 ELECTRICAL CONNECTION: 1-3/8" DIA. HOLE FOR 1" TRADE SIZE CONDUIT; 4-5/8" AFF.
- P1 SINGLE FILL AND RINSE CONNECTION: 3/4" FEMALE GARDEN HOSE FITTING ON 6' LONG HOSE SUPPLIED WITH MACHINE.; 120°F WATER MIN. FOR LXeC, 140°F RECOMMENDED.
- P2 DRAIN CONNECTION: 5/8" BARB FITTING WITH 6' LONG HOSE SUPPLIED WITH MACHINE.

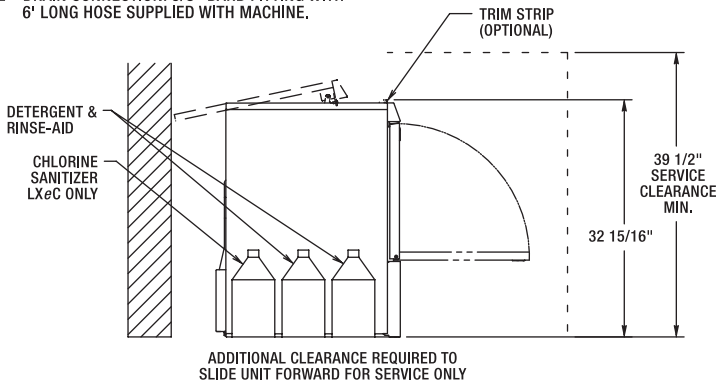

ADDITIONAL CLEARANCE REQUIRED TO SLIDE UNIT FORWARD FOR SERVICE ONLY

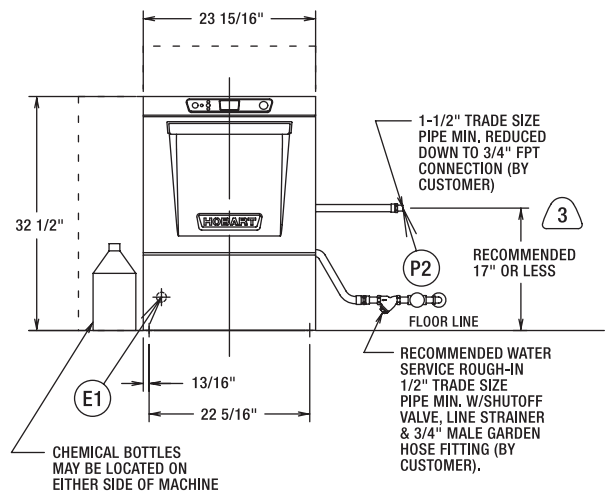
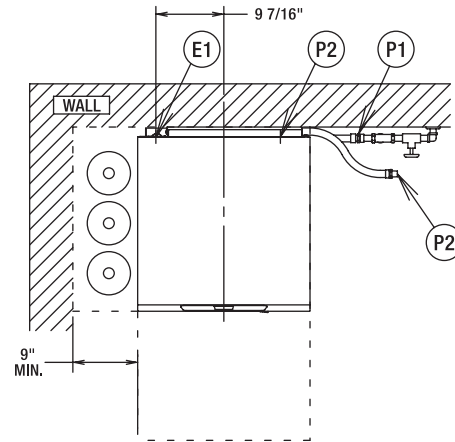

CHEMICAL BOTTLES MAY BE LOCATED ON EITHER SIDE OF MACHINE

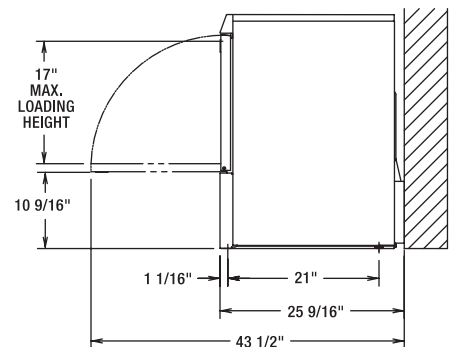

HEAT OUTPUT, BTU/HR		
MODEL	LATENT	SENSIBLE
LXeC	1900	800

SHIPPING WEIGHTS		LXeC
NET WEIGHT OF MACHINE		150 LBS
DOMESTIC SHIPPING WEIGHT		170 LBS

MODEL	VOLTS/HERTZ/PHASE	RATED AMPS	MIN SUPPLY CKT CONDUCTOR AMPACITY	MAX PROTECTIVE DEVICE
LXeC	120/60/1	13.4	20	20

NOTE: FOR SUPPLY CONNECTIONS, USE COPPER WIRE ONLY RATED AT 90°C MINIMUM.
ACCESSORY CORD KIT AVAILABLE FOR ALL MACHINES

⚠ WARNING

Electrical and grounding connections must comply with the applicable portions of the National Electrical Code and/or other local electrical codes.

Plumbing connections must comply with applicable sanitary, safety and plumbing codes. Drain and fill line configurations vary, some methods are shown on this drawing.

**MODELS:
LXeC
00-947871
REV C**

SPECIFICATIONS

DESIGN: Front opening, equipped for installation in either freestanding or undercounter-type operations.

CONSTRUCTION: 300 series stainless steel tank, door and top panel.

PUMP: Centrifugal-type, integral with motor, horizontally mounted. Pump capacity 38 gpm.

MOTOR: Single phase, furnished for all electrical specifications. Factory sealed lubrication. Inherent overload protection with auto reset.

WASH AND RINSE CYCLE: Complete automatic type, controlled by solid-state electronics. Cycle may be interrupted any time by opening door. Cycle continues when door is closed.

- Initial cycle fills wash tank, to be recirculated each wash cycle. Some wash water is drained off before rinse cycle. Rinse cycle refreshes wash water and tank heat.

RINSE PUMP: Powered by a single phase motor, the rinse pump is made of high strength engineered composite material.

RINSE AND SANITATION:

- LXeH:** Sanitation is accomplished by means of a built-in booster heater designed to raise temperature of water to a minimum of 180°F from an incoming water temperature of 110°F.

- LXeC:** Sanitation is accomplished by injection of proper amount of sodium hypochlorite solution (liquid bleach) into final rinse water to achieve a minimum of 50PPM sanitizing solution. Injection of sodium hypochlorite is accomplished by a built-in sanitizing chemical pump.

PUMPED DRAIN: Machine automatically drains water through a built-in pump. Maximum 38" drain height permitted.

RACKING: Machines accommodate racks from 10" x 20" to 20" x 20". Also accepts 16" x 18" cafeteria trays.

NOTE: Certain materials, including silver, aluminum and pewter are attacked by Sodium Hypochlorite solution in the chemical sanitizing mode of operation.

SPECIFICATIONS: Listed by Underwriters Laboratories Inc. and NSF International.

MACHINE RATINGS	LXeC	LXeH
Racks per Hour Rate	34	32
Dishes per Hour (25 per Rack Avg.)	850	800
Glasses per Hour (36 per Rack Avg.)	1224	1152
Controls	Microcomputer	
Tank Capacity - Gallons	2.9	
Overall Dimensions - H x W x D	32½" x 23 ¹⁵ / ₁₆ " x 25 ⁹ / ₁₆ "	
Cycle Time - Seconds	105	109
Tank Heat	1.8 KW	
Electric Booster Heater	N/A	4.9 KW
Water Usage Per Rack - Gallons	.74	
Drain Design	Pumped	
Door Opening Height	17"	
Detergent Pump	Standard	
Rinse-Aid Pump	Standard	
Sanitizer Pump	Standard	N/A
Chemical Prime (auto prime)	Standard	
Peak Drain Flow - GPM	4.0	
Service Diagnostics	Standard	
70° Rise Sense-A-Temp™ Booster Heater	N/A	Standard
Incoming Water Temperature Required (minimum)	120°	110°

As continued product improvement is a policy of Hobart, specifications are subject to change without notice.