



Flav-R-Savor® Large Capacity Display Cabinets

Models: WFST-1X, -2X,
LFST-48-1X, -2X

Hatco's Large Capacity Display Cabinets help you maintain more food at proper serving temperatures. The left and right side heat sources create a "blanket" effect around the food. The air flow rate enables the cabinets to rapidly recover temperature after opening and closing the door. Single-door or two-door option gives you ease of self-serve applications or pass-thru convenience.

WFST (humidified). Prepare food in advance of peak periods and place product straight from the oven into the full-view cabinets to increase impulse sales. The use of controlled moisturized heat maintains serving temperature and texture longer than conventional holding equipment.

LFST (non-humidified) models are perfect for holding wrapped or boxed products side-by-side, increasing visibility and easy access.

Standard features

- Hold standard sheet pans 18" x 26" (457 x 660 mm)
- Tempered glass doors and side panels provide maximum heat retention and allow for full cabinet display
- Shatter-resistant incandescent lights enhance product displays while safeguarding food products from bulb breakage
- Standard multi-purpose rack with adjustable shelves in 2" (51 mm) increments to fit multiple foodservice uses with slant or horizontal shelves

WATER QUALITY REQUIREMENTS (WFST only)

Incoming water in excess of 3.0 grains of hardness per gallon (GPG) (.75 grains of hardness per liter) must be treated and softened before being supplied to booster heater(s). Water containing over 3.0 GPG (.75 GPL) will decrease the efficiency and reduce the operating life of the unit.

Note: Product failure caused by liming or sediment buildup is not covered under warranty.

For operation, location and safety information, please refer to the Installation & Operating Manual.

Project _____

Item # _____

Quantity _____



WFST-1X in standard Unfinished Metal and accessory decals



LFST-2X in Designer Black

Options (available at time of purchase only)

Designer Colors – Non-standard colors are non-returnable

- Unfinished Metal standard on WFST
- Black standard on LFST
- Clear Anodized Aluminum (LFST only)
- Warm Red Black Gray Granite White Granite
- Navy Blue Hunter Green Antique Copper

Self-Closing Sliding Doors (WFST-2X only, in lieu of Hinged Doors on one side only)

Self-Closing French Doors (WFST models only)

60 Watt Halogen Bulb in lieu of Standard Display Light

Accessories

4" (102 mm) Adjustable Legs (WFST models only)



HATCO CORPORATION | P.O. Box 340500 Milwaukee, WI 53234-0500 U.S.A.
(800) 558-0607 | (414) 671-6350 | www.hatcocorp.com | support@hatcocorp.com



Flav-R-Savor® Large Capacity Display Cabinets

Models: WFST-1X, -2X, LFST-48-1X, -2X

WFST MODELS

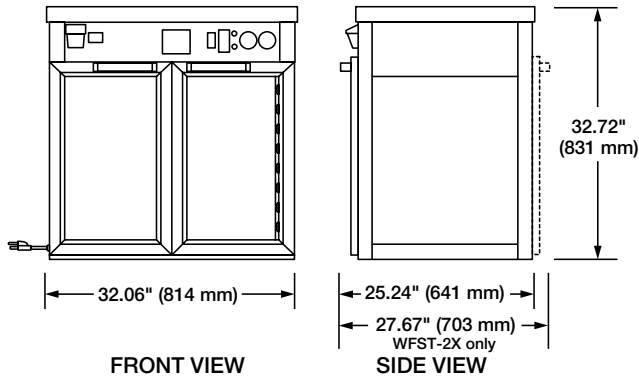

LFST MODELS

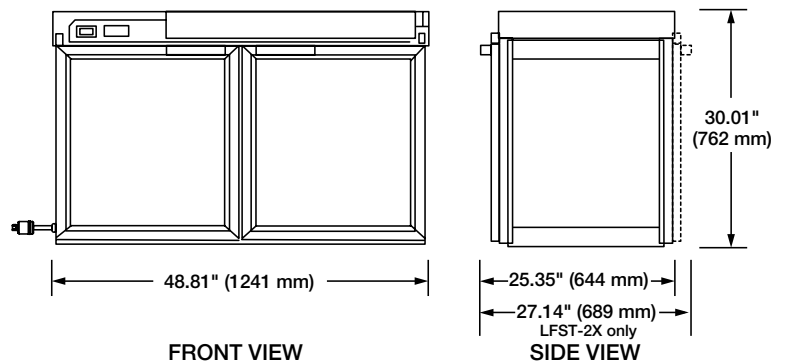

SPECIFICATIONS Large Capacity Holding Cabinets - Humidified

The shaded areas contain electrical information for international models

Model	Bulbs	Description	Dimensions (W x D x H)	Cabinet Opening (W x H)	Volts	Hz	Watts	Amps	Plug	Ship Weight*
WFST-1X	4	2 Doors with 4-shelf rack	32.06" x 25.24" x 32.72" (814 x 641 x 831 mm)	28" x 21.94" (711 x 557 mm)	120	60	1790	14.9	NEMA 5-15P ^F	182 lbs. (83 kg)
					220	50/60	1750	8.0	CEE 7/7 Schuko	
					240	50/60	1790	7.5	BS-1363	
					220-230	50/60	1750-1907	8.0-8.3	CEE 7/7 Schuko	
					230-240	50/60	1650-1790	7.2-7.5	BS-1363	
WFST-2X	4	4 Doors with 4-shelf rack	32.06" x 27.67" x 32.72" (814 x 703 x 831 mm)	28" x 21.94" (711 x 557 mm)	120	60	1790	14.9	NEMA 5-15P ^F	188 lbs. (85 kg)
					220	50/60	1750	8.0	CEE 7/7 Schuko	
					240	50/60	1790	7.5	BS-1363	
					220-230	50/60	1750-1907	8.0-8.3	CEE 7/7 Schuko	
					230-240	50/60	1650-1790	7.2-7.5	BS-1363	

Large Capacity Holding Cabinets - Non-Humidified

Model	Bulbs	Description	Dimensions (W x D x H)	Cabinet Opening (W x H)	Volts	Hz	Watts	Amps	Plug	Ship Weight*
LFST-48-1X	6	2 Doors with 3-shelf rack	48.81" x 25.35" x 30.01" (1240 x 644 x 762 mm)	44" x 22" (1118 x 559 mm)	120/208-240	60	2150	14.6	NEMA L14-20P	222 lbs. (101 kg)
LFST-48-2X	6	4 Doors with 3-shelf rack	48.81" x 27.14" x 30.01" (1240 x 689 x 762 mm)	44" x 22" (1118 x 559 mm)	120/208-240	60	2150	14.6	NEMA L14-20P	230 lbs. (104 kg)

* Shipping weight includes packaging.
^F Canada, use NEMA 5-20P.

WATER TANK CAPACITY

WFST models: ¾ gallon (2.8 liters).

CORD LOCATION

Facing controls, left-hand side panel, lower right corner.

PLUG CONFIGURATIONS

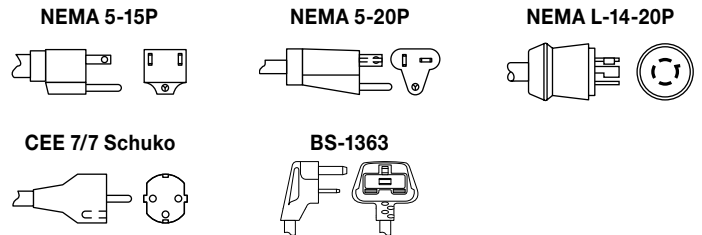

PRODUCT SPECS Large Capacity Display Cabinets

The Large Capacity Display Cabinet shall be a Flav-R-Savor® Model ..., rated at ... volts and ... watts, as manufactured by the Hatco Corporation, Milwaukee, WI 53234 U.S.A.

The WFST cabinet shall have ... door(s), tempered glass sides, adjustable rack, stacking hardware, and incandescent display lights. It shall include a water reservoir, humidity selector switch, temperature selector dial, On/Off switch, indicating lights, and a 6' (1829 mm) cord with plug attached.

Accessories shall include adjustable legs and pans.

The LFST cabinet shall have ... self closing French-style glass doors, incandescent display lights, tempered glass sides, sign holders on all four sides, and removable adjustable rack. It shall include a temperature selector dial, On/Off switch, indicating lights, and a 6' (1829 mm) cord with plug attached.

Accessories shall include pans.

Warranty consists of 24/7 parts and service assistance (US and Canada only).

HATCO CORPORATION | P.O. Box 340500 Milwaukee, WI 53234-0500 U.S.A.
 (800) 558-0607 | (414) 671-6350 | www.hatcocorp.com | support@hatcocorp.com