



Glo-Ray® Designer Horizontal Merchandising Display Warmers

Models: GR2SDH-24, -30, -36, -42, -48, -54, -60
GR2SDH-24D, -30D, -36D, -42D, -48D, -54D, -60D

Hatco's Glo-Ray® Designer Horizontal Merchandising Display Warmers are designed specifically to hold hot wrapped or boxed product safely, and at proper serving temperatures while enhancing your setting with style and color. With pre-focused infrared top heat and a thermostatically-controlled hardcoated heated base, they excel at extending the holding times of most food, offering the convenience of self-serve and the efficiency of kitchen-to-server holding.

Standard features

- Models have pre-focused infrared top heat directing heat to the outer edges of the holding surface where heat loss is the greatest
- Thermostatically-controlled, hardcoated heated base has a temperature range of 185°- 200°F (85°- 93°C)
- Coated shatter-resistant incandescent lights enhance product display while safeguarding food products from bulb breakage
- NSF requires units over 36" (914 mm) in width or weighing more than 80 lbs. (36 kg) to be either sealed to the installation surface or raised with the 4" (102 mm) legs included
- Standard units shipped with: tempered glass side panels, a thermostatically controlled heated base, infrared upper heating elements, incandescent lights, product divider rods, 4" (102 mm) legs and a 6' (1829 mm) cord with plug

Project _____
 Item # _____
 Quantity _____



GR2SDH-30
Horizontal single shelf in optional Designer White Granite and standard Black insets



GR2SDH-30D
Horizontal dual shelf in standard Clear Anodized Aluminum and standard Black insets

Options (available at time of purchase only)

Designer Colors

Non-standard colors are non-returnable –

Clear Anodized Aluminum standard

- Warm Red Black Gray Granite White Granite
 Navy Blue Hunter Green Antique Copper

Designer Inset Panel Colors

Non-standard colors are non-returnable – Black standard

- Warm Red Gray Granite White Granite
 Navy Blue Hunter Green Antique Copper

- Dark Gray Corner Caps – Non-standard colors are non-returnable – Black standard
- 5" (127 mm) Sneeze Guard
- Plexi-Glass Flip Up Doors (split-door on models G2SDH-48 and larger)
- Front Glass in lieu of channel dividers and divider rods. Cannot have Sneeze Guards or Flip-up doors
- 60 Watt Halogen Bulb in lieu of Standard Display Light (not available on export voltages)
- Indicating Temperature Control (LED) (adds 1 7/8" [48 mm] to unit depth)

Accessories

- Stainless Steel Rods
- Flip-up Control Cover

For operation, location and safety information, please refer to the Installation & Operating Manual.





Glo-Ray® Designer Horizontal Merchandising Display Warmers

Models: GR2SDH-24, -30, -36, -42, -48, -54, -60
GR2SDH-24D, -30D, -36D, -42D, -48D, -54D, -60D

HORIZONTAL SINGLE SHELF

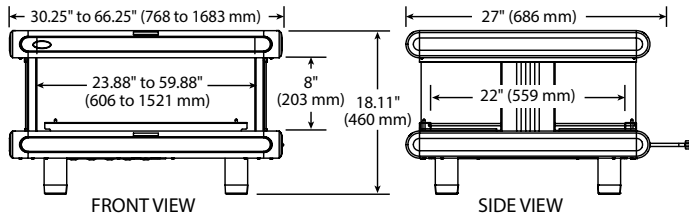

HORIZONTAL DUAL SHELF

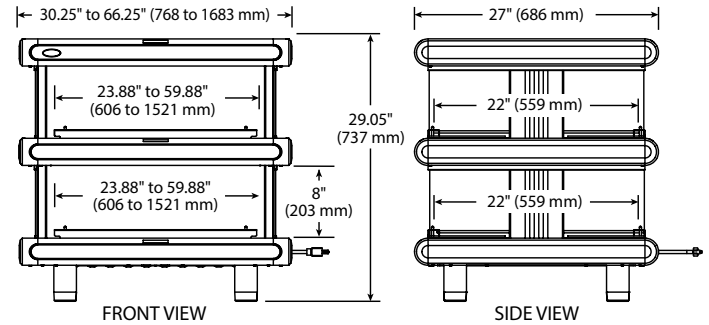

SPECIFICATIONS

Single Shelf – Horizontal Merchandising Display Warmers

The shaded areas contain electrical information for International models

Model	No. of Bulbs, Divider Rods	Dimensions (W x D x H) includes legs	Usable Heated Shelf Space (W x D)	Average Chute Width	Volts	Watts	Amps	Plug	Ship Weight*
GR2SDH-24	2, 5	30.25" x 27" x 18.11" (768 x 686 x 460 mm)	23.87" x 22" (606 x 559 mm)	3.73" (95 mm)	120	820	6.8	NEMA 5-15P	87 lbs. (39 kg)
					220	800	3.6	CEE 7/7 Schuko, BS-1363	
					240	820	3.4	BS-1363, AS 3112	
					220-230 (CE)	800-875	3.6-3.8	CEE 7/7 Schuko, BS-1363	
					230-240 (CE)	753-820	3.3-3.4	BS-1363	
GR2SDH-30	2, 6	36.25" x 27" x 18.11" (921 x 686 x 460 mm)	29.87" x 22" (759 x 559 mm)	4.02" (102 mm)	120	1020	8.5	NEMA 5-15P	120 lbs. (55 kg)
					220	1000	4.5	CEE 7/7 Schuko, BS-1363	
					240	1020	4.3	BS-1363, AS 3112	
					220-230 (CE)	1000-1093	4.5-4.8	CEE 7/7 Schuko, BS-1363	
					230-240 (CE)	937-1020	4.1-4.3	BS-1363	
GR2SDH-36	2, 7	42.25" x 27" x 18.11" (1073 x 686 x 460 mm)	35.87" x 22" (911 x 559 mm)	4.23" (107 mm)	120	1220	10.2	NEMA 5-15P	129 lbs. (59 kg)
					220	1200	5.5	CEE 7/7 Schuko, BS-1363	
					240	1220	5.1	BS-1363, AS 3112	
					220-230 (CE)	1200-1312	5.5-5.7	CEE 7/7 Schuko, BS-1363	
					230-240 (CE)	1120-1220	4.9-5.1	BS-1363	
GR2SDH-42	4, 8	48.25" x 27" x 18.11" (1226 x 686 x 460 mm)	41.87" x 22" (1064 x 559 mm)	4.40" (111 mm)	120	1490	12.4	NEMA 5-15P [▲]	138 lbs. (63 kg)
					220	1450	6.6	CEE 7/7 Schuko, BS-1363	
					240	1490	6.2	BS-1363, AS 3112	
					220-230 (CE)	1450-1585	6.6-6.9	CEE 7/7 Schuko, BS-1363	
					230-240 (CE)	1368-1490	6.0-6.2	BS-1363	
GR2SDH-48	4, 9	54.25" x 27" x 18.11" (1378 x 686 x 460 mm)	47.87" x 22" (1216 x 559 mm)	4.54" (115 mm)	120	1690	14.1	NEMA 5-15P [▲]	160 lbs. (73 kg)
					220	1650	7.5	CEE 7/7 Schuko, BS-1363	
					240	1690	7.1	BS-1363, AS 3112	
					220-230 (CE)	1650-1804	7.5-7.8	CEE 7/7 Schuko, BS-1363	
					230-240 (CE)	1552-1690	6.8-7.1	BS-1363	
GR2SDH-54	4, 10	60.25" x 27" x 18.11" (1530 x 686 x 460 mm)	53.87" x 22" (1368 x 559 mm)	4.65" (118 mm)	120	1890	15.8	NEMA 5-20P	172 lbs. (78 kg)
					220	1850	8.4	CEE 7/7 Schuko, BS-1363	
					240	1890	7.9	BS-1363, AS 3112	
					220-230 (CE)	1850-2022	8.4-8.8	CEE 7/7 Schuko, BS-1363	
					230-240 (CE)	1736-1890	7.6-7.9	BS-1363	
GR2SDH-60	6, 12	66.25" x 27" x 18.11" (1683 x 686 x 460 mm)	59.87" x 22" (1521 x 559 mm)	4.36" (110 mm)	120	2210	18.4	NEMA 5-30P	200 lbs. (91 kg)
					220	2150	9.8	CEE 7/7 Schuko, BS-1363	
					240	2210	9.2	BS-1363, AS 3112	
					220-230 (CE)	2150-2350	9.8-10.2	CEE 7/7 Schuko, BS-1363	
					230-240 (CE)	2030-2210	8.8-9.2	BS-1363	

* Shipping weight includes packaging.

▲ Canadian models use NEMA 5-20P.

HATCO CORPORATION | P.O. Box 340500 Milwaukee, WI 53234-0500 U.S.A.
(800) 558-0607 | (414) 671-6350 | www.hatcocorp.com | support@hatcocorp.com



Glo-Ray® Designer Horizontal Merchandising Display Warmers

Models: GR2SDH-24, -30, -36, -42, -48, -54, -60
GR2SDH-24D, -30D, -36D, -42D, -48D, -54D, -60D

SPECIFICATIONS Dual Shelf — Horizontal Merchandising Display Warmers

The shaded areas contain electrical information for International models

Model	No. of Bulbs, Divider Rods	Dimensions (W x D x H) includes legs	Usable Heated Shelf Space (W x D)	Average Chute Width	Volts	Watts	Amps	Plug	Ship Weight*
GR2SDH-24D	4, 10	30.25" x 27" x 29.05" (768 x 686 x 737 mm)	23.87" x 22" (606 x 559 mm)	3.73" (95 mm)	120	1640	13.7	NEMA 5-15P [▲]	126 lbs. (57 kg)
					220	1600	7.3	CEE 7/7 Schuko, BS-1363	
					240	1640	6.8	BS-1363, AS 3112	
					220-230 (CE)	1600-1749	7.3-7.6	CEE 7/7 Schuko, BS-1363	
					230-240 (CE)	1506-1640	6.6-6.8	BS-1363	
GR2SDH-30D	4, 12	36.25" x 27" x 29.05" (921 x 686 x 737 mm)	29.87" x 22" (759 x 559 mm)	4.02" (102 mm)	120/208	2040	8.5	NEMA L14-20P	158 lbs. (72 kg)
					120/240	2040	8.5	NEMA L14-20P	
					220	2000	9.1	CEE 7/7 Schuko, BS-1363	
					240	2040	8.5	BS-1363, AS 3112	
					220-230 (CE)	2000-2186	9.1-9.5	CEE 7/7 Schuko, BS-1363	
GR2SDH-36D	4, 14	42.25" x 27" x 29.05" (1073 x 686 x 737 mm)	35.87" x 22" (911 x 559 mm)	4.23" (107 mm)	120/208	2440	10.2	NEMA L14-20P	205 lbs. (93 kg)
					120/240	2440	10.2	NEMA L14-20P	
					220	2400	10.9	CEE 7/7 Schuko, BS-1363	
					240	2440	10.2	BS-1363, AS 3112	
					220-230 (CE)	2400-2623	10.9-11.4	CEE 7/7 Schuko, BS-1363	
GR2SDH-42D	8, 16	48.25" x 27" x 29.05" (1226 x 686 x 737 mm)	41.87" x 22" (1064 x 559 mm)	4.40" (111 mm)	120/208	2980	12.4	NEMA L14-20P	225 lbs. (102 kg)
					120/240	2980	12.4	NEMA L14-20P	
					220	2900	13.2	CEE 7/7 Schuko, No Plug	
					240	2980	12.4	BS-1363, AS 3112	
					220-230 (CE)	2900-3170	13.2-13.8	CEE 7/7 Schuko, No Plug	
GR2SDH-48D	8, 18	54.25" x 27" x 29.05" (1378 x 686 x 737 mm)	47.87" x 22" (1216 x 559 mm)	4.54" (115 mm)	120/208	3380	14.1	NEMA L14-20P	254 lbs. (115 kg)
					120/240	3380	14.1	NEMA L14-20P	
					220	3300	15.0	CEE 7/7 Schuko, No Plug	
					240	3380	14.1	AS 3112, No Plug	
					220-230 (CE)	3300-3607	15.0-15.7	CEE 7/7 Schuko, No Plug	
GR2SDH-54D	8, 20	60.25" x 27" x 29.05" (1530 x 686 x 737 mm)	53.87" x 22" (1368 x 559 mm)	4.65" (118 mm)	120/208	3780	15.8	NEMA L14-20P	274 lbs. (124 kg)
					120/240	3780	15.8	NEMA L14-20P	
					220	3700	16.8	No Plug	
					240	3780	15.8	No Plug	
					220-230 (CE)	3700-4044	16.8-17.6	No Plug	
GR2SDH-60D	12, 24	66.25" x 27" x 29.05" (1683 x 686 x 737 mm)	59.87" x 22" (1521 x 559 mm)	4.36" (110 mm)	120/208	4420	18.4	NEMA L14-30P	328 lbs. (149 kg)
					120/240	4420	18.4	NEMA L14-30P	
					220	4300	19.6	No Plug	
					240	4420	18.4	No Plug	
					220-230 (CE)	4300-4700	19.6-20.4	No Plug	
					230-240 (CE)	4049-4420	17.6-18.4	No Plug	

* Shipping weight includes packaging. ▲ Canadian models use NEMA 5-20P.

PLUG CONFIGURATIONS

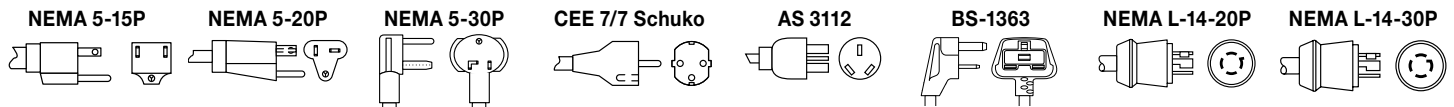

CORD LOCATION

Back of unit, top right side.

PRODUCT SPECS

Glo-Ray® Designer Horizontal Merchandising Warmers

The Designer Merchandising Warmer shall be a Glo-Ray® Model ... as manufactured by the Hatco Corporation, Milwaukee, WI 53234 U.S.A.

The warmer shall be rated at ... watts, ... volts, and be ... inches (millimeters) in overall width. It shall consist of a thermostatically-controlled hardcoated heated base, infrared heat from above, full view tempered glass sides, adjustable divider rods, Designer

color inset panels and incandescent display lights. The infrared heating element shall be tubular metal sheathed and the warmer shall have a 6' (1829 mm) cord with plug attached.

Accessories shall include control covers and additional stainless steel dividers rods.

Warranty consists of 24/7 parts and service assistance (US and Canada only).

HATCO CORPORATION | P.O. Box 340500 Milwaukee, WI 53234-0500 U.S.A.
(800) 558-0607 | (414) 671-6350 | www.hatcocorp.com | support@hatcocorp.com