



Project _____
 Item # _____
 Quantity _____

FR2 Hydro-Heater Food Rethermalizers / Bain-Marie Heaters

Models: FR2-3, -4, -6, -9,
 FR2-3B, -4B, -6B, -9B

The patented Hatco FR2 Hydro-Heater Food Rethermalizers / Bain-Marie Heaters are designed to supply temperature-controlled water to a sink mounted above the heater. Utilizing "free-flow" technology to ensure a responsive and efficient operation, the FR2 models can heat or hold foods at safe-serving temperatures between 140°F (60°C) to 190°F (88°C).

Standard features

- An electronic controller with digital display maintains an accurate setpoint temperature
- Features a tubular water chamber with a spiral heating element wrapped outside the flow tube so elements do not come in direct contact with the water
- Unit includes a stainless steel front, powdercoated body, low-water cut-off system, convenient drain outlet and clean-out caps



FR2-6

Options (available at time of purchase only)

- All Stainless Steel Body and Base
- Auto-fill Solenoid
- Remote Mounted Control
- Security Package (Torx® Screws and Control Cover)

Accessories

- Flush Kit (Flush Hose, Cleaning Brush, Stopper and Adapter)

FOOD RETHERMALIZING REQUIREMENTS

NSF Standard 4 has added performance requirements for food rethermalizing. The requirements mirror the requirements for food rethermalizing in the FDA Food Code. The basic requirement is that food reaches a temperature of 165°F (74°C) in a time period of two hours or less.

Appliances that are manufactured for the purpose of rethermalizing food will need to meet these performance requirements in order to be listed to NSF Standard 4.

The Hatco FR2 series Hydro-Heater is specifically made to be used for food rethermalizing, however, the heating unit is designed to be incorporated into a hot water bath rethermalizer. Hatco does not supply the vessel that contains the water, nor the system which determines how food is placed and held in the vessel. The Hatco FR2 unit simply attaches to the bottom of the vessel and supplies hot water to the vessel.

Hatco does supply sizing recommendations to enable the appliance manufacturer to correctly size the FR2 unit to the vessel. However, there are variables in the way that the vessel is manufactured that affect its ability to pass the NSF performance requirements. The Hatco FR2 unit is UL Classified on NSF 4 for construction only. Due to the fact that the FR2 is only a portion of a larger system, it is impossible to do performance testing until the FR2 unit is incorporated onto the water vessel.

The result is that it is the responsibility of the vessel manufacturer to have the entire rethermalizing appliance tested and listed in accordance with NSF Standard 4.

For operation, location and safety information, please refer to the Installation & Operating Manual.



ANSI/NSF 4



HATCO CORPORATION | P.O. Box 340500 Milwaukee, WI 53234-0500 U.S.A.
 (800) 558-0607 | (414) 671-6350 | www.hatcocorp.com | support@hatcocorp.com



FR2 Hydro-Heater Food Rethermalizers / Bain-Marie Heaters

Models: FR2-3, -4, -6, -9, FR2-3B, -4B, -6B, -9B

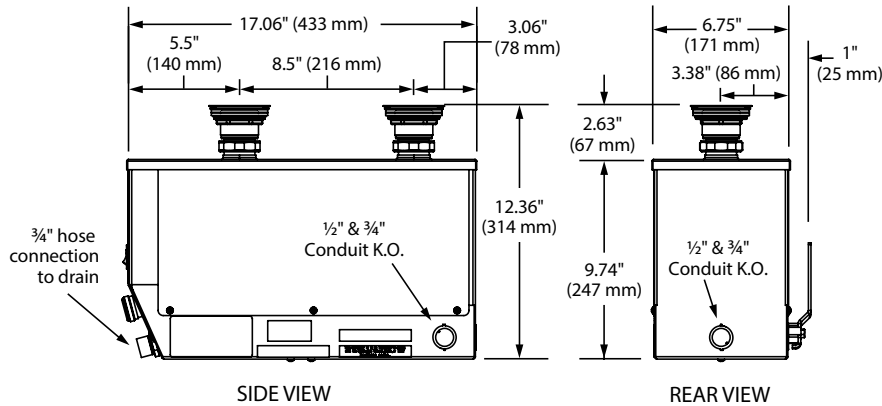

SIZING INFORMATION

For a Bain-Marie or Steam Table: MINIMUM 750 WATTS PER SQUARE FOOT (0.8 WATTS PER SQUARE CM) of vessel top.

For a Food Rethermalizer: MINIMUM 2000 WATTS PER SQUARE FOOT (2.2 WATTS PER SQUARE CM) of vessel top.

Use one FR2 for a Bain-Marie up to 6' (1829 mm) long. Over 6', minimum two required.

MUST BE INSTALLED WITH A PERFORATED WATER BAFFLE. This baffle is not supplied with heater. The FR2 should be positioned with no more than 3" (914 mm) on either side when mounted in holding vessel. Consult factory or installation manual for fabricating details.

SPECIFICATIONS

FR2 Hydro-Heater Food Rethermalizers / Bain-Marie Heaters

Model	Dimensions (Width x Depth x Height)	Voltage	Hertz	kW	Phase	Amps	Wiring Sizing AWG [†]	Fuse or Circuit Breaker [†]	Ship Weight [*]		
FR2-3	7.75" x 17.06" x 12.36" (197 x 433 x 314 mm)	208	50/60	3.0	Single	14.4	12	20	34 lbs. (15 kg)		
FR2-4		208		4.0		19.2		30			
		240		16.7							
FR2-6		208		6.0	28.8	10	40				
FR2-3B		208		Three (Bal.)	3.0	14	8.4	15			
		240			7.3						
FR2-4B		208			4.0		11.2				
		240			9.6						
FR2-6B		208			6.0		16.7			12	30
		240			14.5		20				
FR2-9B	208	9.0	25	10	40						

[‡] Wire size is based on THHN copper wire for branch circuit protection at 0.91 derate factor. Circuit breakers and fused disconnects are to be mounted remote and wired by contractor. Sizes are based on the 2002 NEC table 310-16. Conduit size based on conductors plus ground wire sizing per Table C1 from Appendix C.

[†] Based upon THHN wire rated 90°C.

* Shipping weight includes packaging.

PLUG CONFIGURATIONS

NEMA 6-20P
(Available for FR2-3 only)

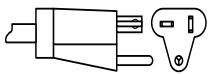

NEMA 6-30P
(Available for FR2-4 only)

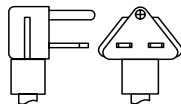

WATER QUALITY REQUIREMENTS

Incoming water in excess of 3.0 grains of hardness per gallon (GPG) (.75 grains of hardness per liter) must be treated and softened before being supplied to hot water dispenser(s). Water containing over 3.0 GPG (.75 GPL) will decrease efficiency and reduce the operating life of the unit.

Note: Product failure caused by liming or sediment buildup is not covered under warranty.

PRODUCT SPECS

FR2 Hydro-Heater Food Rethermalizers / Bain-Marie Heaters

The electric heater shall be a Hydro-Heater Model manufactured by the Hatco Corporation, Milwaukee, WI 53234 U.S.A.

The electric heater shall be rated at ... kW, ... volts, ... phase. The heater shall be complete with all internal plumbing and wiring ready for external installation to the bottom of the holding vessel.

The heater shall consist of 1 to 3 stainless steel tubes wrapped with external heating elements. Each tube may be accessed for cleaning purposes. The unit may be emptied easily by a convenient drain.

The heater shall be equipped with an electronic temperature controller adjustable from 140°F to 190°F (60° to 88°C), an on-off switch, a low-water cut-off, and a digital temperature display.

The heater shall consist of powdercoated black hammertone front and body (or optional stainless steel body and base).

Warranty consists of 24/7 parts and service assistance (US and Canada only).

HATCO CORPORATION | P.O. Box 340500 Milwaukee, WI 53234-0500 U.S.A.
(800) 558-0607 | (414) 671-6350 | www.hatcocorp.com | support@hatcocorp.com