



Project _____

Item # _____

Quantity _____

Cold Shelves Undermount and Built-In Flush Top

Models: CSU-24-F, -24-I, -24-S, -36-F, -36-I, -36-S, -48-F, -48-I, -48-S

CSBF-24-F, -24-I, -24-S, -36-F, -36-I, -36-S, -48-F, -48-I, -48-S

Hatco's Cold Shelves Undermount and Built-In Flush Top are designed to keep your products in the perfect chill zone.

Undermount shelves offer the same great performance as the Built-In Flush Top model, but can be installed under the counter top of your choice!

Standard features

- R-513A refrigerant available for California only, please contact Hatco for more information
- Long, flexible refrigerant line (ability to pullout condensing unit) for service
- Patented thermal break reduces condensation and temperature transfer on CSBF models
- CSBF models have an aluminum hard coat surface, while CSU models have an aluminum surface
- The CSBF Cold Built-In Shelves match the GRSBF Heated Built-In Shelves for a fully integrated look
- For CSU models: mount under a granite or quartz countertop .75" to 1.19" (20 to 30 mm) thick or less for a seamless look*
- Models shipped with Electronic Temperature Control and Condensing Unit
- Control box can be mounted on the front of the cabinet, 4' (1219 mm) from center of shelf
- Condensing unit may be mounted up to 4' (1219 mm) away from the center of shelf
- Shelf construction utilizes R-404A refrigerant
- Easy serviceability with a sight glass, service valves, dryer/filter, and a receiver

* Make structural modifications or add bracing underneath the countertop to ensure countertop will support the weight of the unit and its contents.

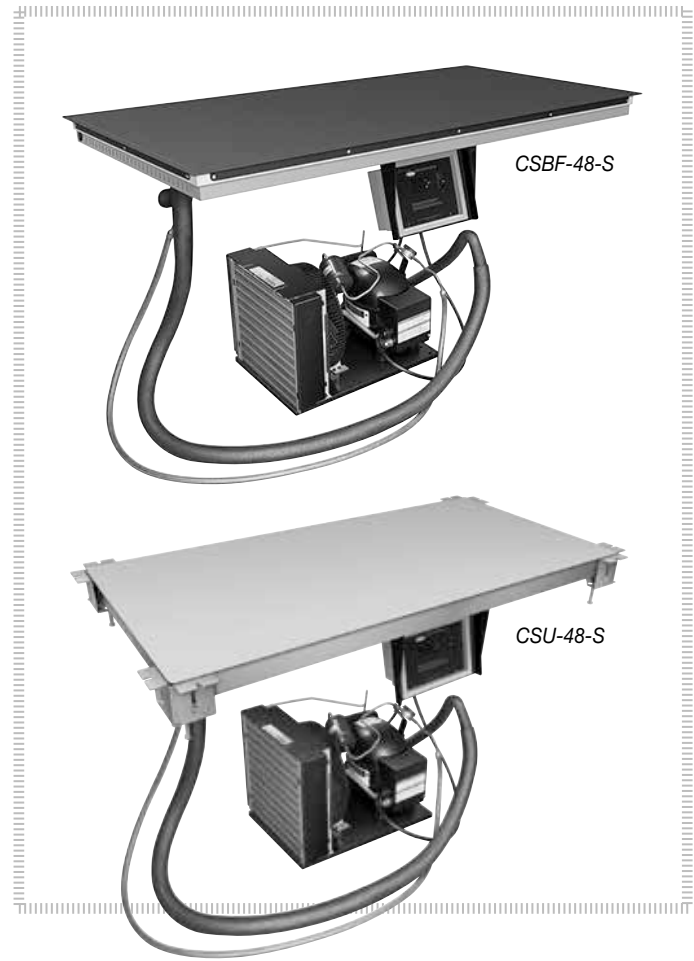

Options (available at time of purchase only)

- Additional four year parts only warranty on the compressor available at time of purchase (U.S. and Canada only)

For operation, location and safety information, please refer to the Installation & Operating Manual.



HATCO CORPORATION | P.O. Box 340500 Milwaukee, WI 53234-0500 U.S.A.
(800) 558-0607 | (414) 671-6350 | www.hatcocorp.com | support@hatcocorp.com



Cold Shelves Undermount and Built-In Flush Top

Models: CSU-24-F, -24-I, -24-S, -36-F, -36-I, -36-S, -48-F, -48-I, -48-S

CSBF-24-F, -24-I, -24-S, -36-F, -36-I, -36-S, -48-F, -48-I, -48-S

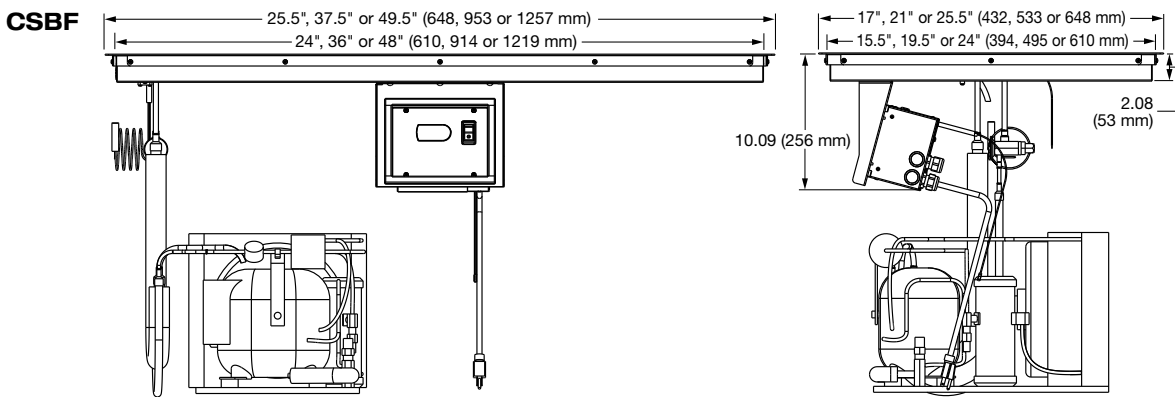
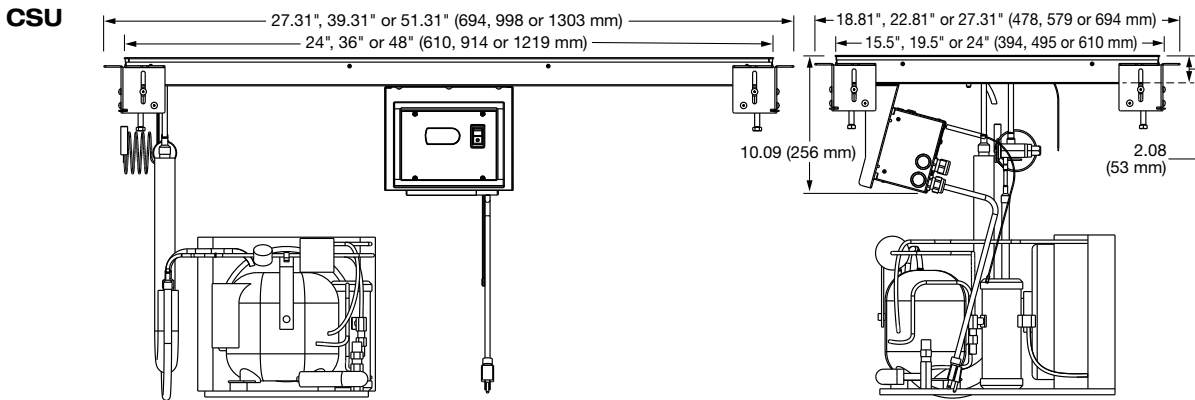

Contact Hatco for R-513A refrigerant specifications.

SPECIFICATIONS

Cold Shelves Undermount*

The shaded areas contain electrical information for International models

Model	Overall Dimensions W x D x H	Usable Shelf Space W x D	Compressor Size HP	Volts*	Watts	Amps	Hz	Plug	Approximate Ship Weight
CSU-24-F	27.31" x 18.81" x 10.09" (694 x 478 x 256 mm)	24" x 15.5" (610 x 394 mm)	1/4	120	804	6.7	60	NEMA 5-15P	118 lbs. (54 kg)
				1/3	220	616	2.8	50	
			230		667	2.9	60	BS-1363	
			240		744	3.1			
			220		686	3.1	60	BS-1363	
			230	749	3.3				
240	816	3.4							
CSU-24-I	27.31" x 22.81" x 10.09" (694 x 579 x 256 mm)	24" x 19.5" (610 x 495 mm)	1/4	120	804	6.7	60	NEMA 5-15P	115 lbs. (52 kg)
				1/3	220	616	2.8	50	
			230		667	2.9	60	BS-1363	
			240		744	3.1			
			220		686	3.1	60	BS-1363	
			230	749	3.3				
240	816	3.4							
CSU-24-S	27.31" x 27.31" x 10.09" (694 x 694 x 256 mm)	24" x 24" (610 x 610 mm)	1/4	120	804	6.7	60	NEMA 5-15P	130 lbs. (59 kg)
				1/3	220	616	2.8	50	
			230		667	2.9	60	BS-1363	
			240		744	3.1			
			220		686	3.1	60	BS-1363	
			230	749	3.3				
240	816	3.4							

*All voltages non-CE

* Contact Hatco for R-513A refrigerant specifications.

(continued on next page)

HATCO CORPORATION

(800) 558-0607 | (414) 671-6350

P.O. Box 340500 Milwaukee, WI 53234-0500 U.S.A.

www.hatcocorp.com | support@hatcocorp.com



Cold Shelves Undermount and Built-In Flush Top

Models: CSU-24-F, -24-I, -24-S, -36-F, -36-I, -36-S, -48-F, -48-I, -48-S
 CSBF-24-F, -24-I, -24-S, -36-F, -36-I, -36-S, -48-F, -48-I, -48-S

SPECIFICATIONS

Cold Shelves Undermount* (continued from previous page)

The shaded areas contain electrical information for International models

Model	Overall Dimensions W x D x H	Usable Shelf Space W x D	Compressor Size HP	Volts*	Watts	Amps	Hz	Plug	Approximate Ship Weight
CSU-36-F	39.31" x 18.81" x 10.09" (998 x 478 x 256 mm)	36" x 15.5" (914 x 394 mm)	1/4	120	804	6.7	60	NEMA 5-15P	143 lbs. (65 kg)
			1/3	220	616	2.8	50	CEE 7-7 Schuko, BS-1363, AS3112	
				230	667	2.9			
				240	744	3.1			
			1/3	220	686	3.1	60	BS-1363	
				230	749	3.3			
240	816	3.4							
CSU-36-I	39.31" x 22.81" x 10.09" (998 x 579 x 256 mm)	36" x 19.5" (914 x 495 mm)	1/3	120	468	6.5	60	NEMA 5-15P	140 lbs. (64 kg)
			3/8	220	807	3.7	50	CEE 7-7 Schuko, BS-1363, AS3112	
				230	882	3.8			
				240	960	4.0			
			1/3	220	686	3.1	60	BS-1363	
				230	749	3.3			
240	816	3.4							
CSU-36-S	39.31" x 27.31" x 10.09" (998 x 694 x 256 mm)	36" x 24" (914 x 610 mm)	1/3	120	468	6.5	60	NEMA 5-15P	144 lbs. (66 kg)
			3/8	220	807	3.7	50	CEE 7-7 Schuko, BS-1363, AS3112	
				230	882	3.8			
				240	960	4.0			
			1/3	220	686	3.1	60	BS-1363	
				230	749	3.3			
240	816	3.4							
CSU-48-F	51.31" x 18.81" x 10.09" (1303 x 478 x 256 mm)	48" x 15.5" (1219 x 394 mm)	1/3	120	468	6.5	60	NEMA 5-15P	141 lbs. (64 kg)
			3/8	220	807	3.7	50	CEE 7-7 Schuko, BS-1363, AS3112	
				230	882	3.8			
				240	960	4.0			
			1/3	220	686	3.1	60	BS-1363	
				230	749	3.3			
240	816	3.4							
CSU-48-I	51.31" x 22.81" x 10.09" (1303 x 579 x 256 mm)	48" x 19.5" (1219 x 495 mm)	1/3	120	468	6.5	60	NEMA 5-15P	154 lbs. (70 kg)
			3/8	220	807	3.7	50	CEE 7-7 Schuko, BS-1363, AS3112	
				230	882	3.8			
				240	960	4.0			
			1/3	220	686	3.1	60	BS-1363	
				230	749	3.3			
240	816	3.4							
CSU-48-S	51.31" x 27.31" x 10.09" (1303 x 694 x 256 mm)	48" x 24" (1219 x 610 mm)	1/2	120	1380	11.5	60	NEMA 5-15P	176 lbs. (80 kg)
			1/2	220	1190	5.4	50	CEE 7-7 Schuko, BS-1363, AS3112	
				230	1300	5.7			
				240	1416	5.9			
			1/2	220	1210	5.5	60	BS-1363	
				230	1322	5.8			
240	1440	6.0							

*All voltages non-CE

* Contact Hatco for R-513A refrigerant specifications.



Cold Shelves Undermount and Built-In Flush Top

Models: CSU-24-F, -24-I, -24-S, -36-F, -36-I, -36-S, -48-F, -48-I, -48-S
 CSBF-24-F, -24-I, -24-S, -36-F, -36-I, -36-S, -48-F, -48-I, -48-S

SPECIFICATIONS

Cold Shelves Built-In Flush Top*

The shaded areas contain electrical information for International models

Model	Overall Dimensions W x D x H	Usable Shelf Space W x D	Compressor Size HP	Volts*	Watts	Amps	Hz	Plug	Approximate Ship Weight
CSBF-24-F	25.5" x 17" x 10.09" (648 x 432 x 256 mm)	24" x 15.5" (610 x 394 mm)	1/4	120	804	6.7	60	NEMA 5-15P	108 lbs. (49 kg)
			1/3	220	616	2.8	50	CEE 7-7 Schuko, BS-1363, AS3112	
				230	667	2.9			
				240	744	3.1			
			1/3	220	686	3.1	60	BS-1363	
				230	749	3.3			
240	816	3.4							
CSBF-24-I	25.5" x 21" x 10.09" (648 x 533 x 256 mm)	24" x 19.5" (610 x 495 mm)	1/4	120	804	6.7	60	NEMA 5-15P	116 lbs. (53 kg)
			1/3	220	616	2.8	50	CEE 7-7 Schuko, BS-1363, AS3112	
				230	667	2.9			
				240	744	3.1			
			1/3	220	686	3.1	60	BS-1363	
				230	749	3.3			
240	816	3.4							
CSBF-24-S	25.5" x 25.5" x 10.09" (648 x 648 x 256 mm)	24" x 24" (610 x 610 mm)	1/4	120	804	6.7	60	NEMA 5-15P	124 lbs. (56 kg)
			1/3	220	616	2.8	50	CEE 7-7 Schuko BS-1363, AS3112	
				230	667	2.9			
				240	744	3.1			
			1/3	220	686	3.1	60	BS-1363	
				230	749	3.3			
240	816	3.4							
CSBF-36-F	37.5" x 17" x 10.09" (953 x 432 x 256 mm)	36" x 15.5" (914 x 394 mm)	1/4	120	804	6.7	60	NEMA 5-15P	121 lbs. (55 kg)
			1/3	220	616	2.8	50	CEE 7-7 Schuko, BS-1363, AS3112	
				230	667	2.9			
				240	744	3.1			
			1/3	220	686	3.1	60	BS-1363	
				230	749	3.3			
240	816	3.4							
CSBF-36-I	37.5" x 21" x 10.09" (953 x 533 x 256 mm)	36" x 19.5" (914 x 495 mm)	1/3	120	468	6.5	60	NEMA 5-15P	137 lbs. (62 kg)
			3/8	220	807	3.7	50	CEE 7-7 Schuko, BS-1363, AS3112	
				230	882	3.8			
				240	960	4.0			
			1/3	220	686	3.1	60	BS-1363	
				230	749	3.3			
240	816	3.4							
CSBF-36-S	37.5" x 25.5" x 10.09" (953 x 648 x 256 mm)	36" x 24" (914 x 610 mm)	1/3	120	468	6.5	60	NEMA 5-15P	151 lbs. (69 kg)
			3/8	220	807	3.7	50	CEE 7-7 Schuko, BS-1363, AS3112	
				230	882	3.8			
				240	960	4.0			
			1/3	220	686	3.1	60	BS-1363	
				230	749	3.3			
240	816	3.4							
CSBF-48-F	49.5" x 17" x 10.09" (1257 x 432 x 256 mm)	48" x 15.5" (1219 x 394 mm)	1/3	120	468	6.5	60	NEMA 5-15P	138 lbs. (63 kg)
			3/8	220	807	3.7	50	CEE 7-7 Schuko, BS-1363, AS3112	
				230	882	3.8			
				240	960	4.0			
			1/3	220	686	3.1	60	BS-1363	
				230	749	3.3			
240	816	3.4							
CSBF-48-I	49.5" x 21" x 10.09" (1257 x 533 x 256 mm)	48" x 19.5" (1219 x 495 mm)	1/3	120	468	6.5	60	NEMA 5-15P	157 lbs. (71 kg)
			3/8	220	807	3.7	50	CEE 7-7 Schuko, BS-1363, AS3112	
				230	882	3.8			
				240	960	4.0			
			1/3	220	686	3.1	60	BS-1363	
				230	749	3.3			
240	816	3.4							
CSBF-48-S	49.5" x 25.5" x 10.09" (1257 x 648 x 256 mm)	48" x 24" (1219 x 610 mm)	1/2	120	1380	11.5	60	NEMA 5-15P	177 lbs. (80 kg)
			1/2	220	1190	5.4	50	CEE 7-7 Schuko, BS-1363, AS3112	
				230	1300	5.7			
				240	1416	5.9			
			1/2	220	1210	5.5	60	BS-1363	
				230	1322	5.8			
240	1440	6.0							

*All voltages non-CE

* Contact Hatco for R-513A refrigerant specifications.

HATCO CORPORATION | P.O. Box 340500 Milwaukee, WI 53234-0500 U.S.A.
 (800) 558-0607 | (414) 671-6350 | www.hatcocorp.com | support@hatcocorp.com



Cold Shelves Undermount and Built-In Flush Top

Models: CSU-24-F, -24-I, -24-S, -36-F, -36-I, -36-S, -48-F, -48-I, -48-S
 CSBF-24-F, -24-I, -24-S, -36-F, -36-I, -36-S, -48-F, -48-I, -48-S

PLUG CONFIGURATION

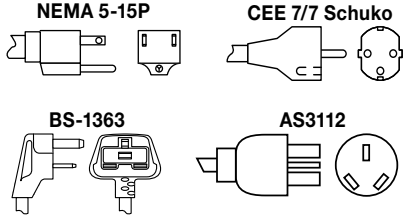

COUNTERTOP CUTOUT DIMENSIONS

See Installation and Operating Manual for more information

Model	Width		Depth	
	Minimum	Maximum	Minimum	Maximum
CSBF-24-F	24.6" (625 mm)	25.0" (635 mm)	16.125" (409 mm)	16.5" (419 mm)
CSBF-24-I	24.6" (625 mm)	25.0" (635 mm)	20.125" (511 mm)	20.5" (521 mm)
CSBF-24-S	24.6" (625 mm)	25.0" (635 mm)	24.6" (625 mm)	25.0" (635 mm)
CSBF-36-F	36.6" (930 mm)	37.0" (940 mm)	16.125" (409 mm)	16.5" (419 mm)
CSBF-36-I	36.6" (930 mm)	37.0" (940 mm)	20.125" (511 mm)	20.5" (521 mm)
CSBF-36-S	36.6" (930 mm)	37.0" (940 mm)	24.6" (625 mm)	25.0" (635 mm)
CSBF-48-F	48.6" (1234 mm)	49.0" (1245 mm)	16.125" (409 mm)	16.5" (419 mm)
CSBF-48-I	48.6" (1234 mm)	49.0" (1245 mm)	20.125" (511 mm)	20.5" (521 mm)
CSBF-48-S	48.6" (1234 mm)	49.0" (1245 mm)	24.6" (625 mm)	25.0" (635 mm)
Model	Width <i>(should not exceed)</i>		Height <i>(should not exceed)</i>	
Control Box	7.44" (189 mm)		5.6" (143 mm)	

PRODUCT SPECS

Cold Shelves Undermount and Built-In Flush Top

The Cold Shelves Undermount and Built-In Flush Top, patent pending, shall be model ... as manufactured by the Hatco Corporation, Milwaukee, WI 53234 U.S.A.

The Cold Shelves Undermount and Built-In Flush Top shall be rated at ... watts, ... volts, and ... inches (millimeters) in overall width.

It shall utilize R-404A or R-513A refrigerant and consist of food-safe material (CSBF

model only – CSU models will be mounted under foodsafe material), Condenser attached to Evaporator with 5 foot (1524 mm) flexible tubing, adjustable bracket with cord and plug attached.

Warranty consists of 24/7 parts and service assistance (U.S. and Canada only).

HATCO CORPORATION | P.O. Box 340500 Milwaukee, WI 53234-0500 U.S.A.
 (800) 558-0607 | (414) 671-6350 | www.hatcocorp.com | support@hatcocorp.com