

Project Name: _____ AIA#: _____

Model #: _____ Location: _____

SIS#: _____ Item #: _____ Quantity: _____



Premium Heavy-Duty Manual Slicer

Precise - Powerful - Premium Construction

The all-new, heavy-duty S-Series line of premium slicers from Globe delivers **precision, performance, industry-leading convenience, superior cleanability and lasting value.**



S13

NEW! Removable Knife makes cleanup easier while providing more operator protection



Model

S13 (Standard Model)

S13 Standard Features

- Patented anodized aluminum design & construction for quick and easy cleaning
- Patent-pending indexing system enables accurate and precise slice thickness adjustment up to 1-1/8"
- 13" steel knife with hardened edge provides quality slices and higher yield
- Tilting carriage accommodates up to 13.75" H, 8" dia., 11" W large products, like prosciutto, mortadella and bacon
- Advanced meat grip design for superior product hold
- 1/2 HP continuous use knife motor combined with the high efficiency knife drive system delivers optimum power
- No Voltage Release prevents inadvertent reactivation of slicer in the event of interlock or power interruption
- Interlock prevents slicer from operating without the knife cover in place
- Top mounted, removable sharpening system utilizes long-lasting synthetic diamond surfaces and enables quick and easy sharpening and cleaning
- Kickstand to facilitate ease of cleaning

Warranty

- Two year parts and labor
- Lifetime warranty on sharpening stones

Factory Installed Options

- **NEW!** KNIFE-RMV - Removable Knife includes removal tool
- **NEW!** CARRIAGE-RMV - Removable Carriage
- FRZN - Serrated knife in lieu of standard knife and additional modifications, single speed at 30 strokes per minute
- CORR - Correctional Package
- MEATROOM - High moisture applications (w/ stainless steel knife)
- SSK - Stainless Steel Knife in lieu of Carbon Steel

Optional Accessories

- S-FENCE - Food Fence
- S-VEGHOP - Vegetable Hopper
- SC-LARGE - Slicer Cover
- S-SLAWTRAY - Slaw Tray
- S-LEGS - 2.5" Extension Legs
- S-XDSLML - Extended Warranty

To select factory-installed options and accessories, see back



Approved by: _____ Date: _____

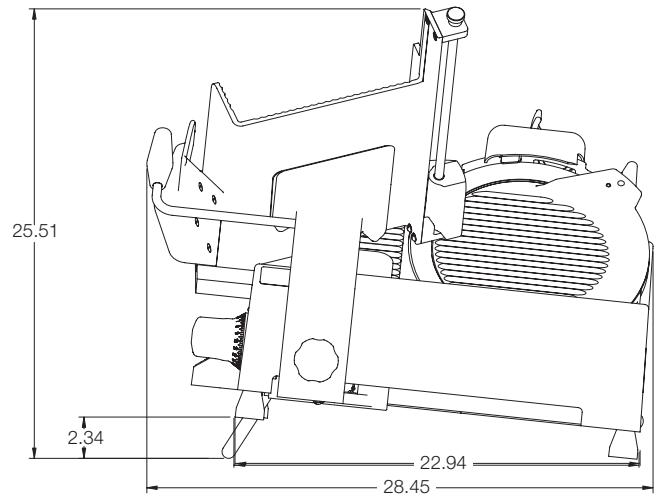
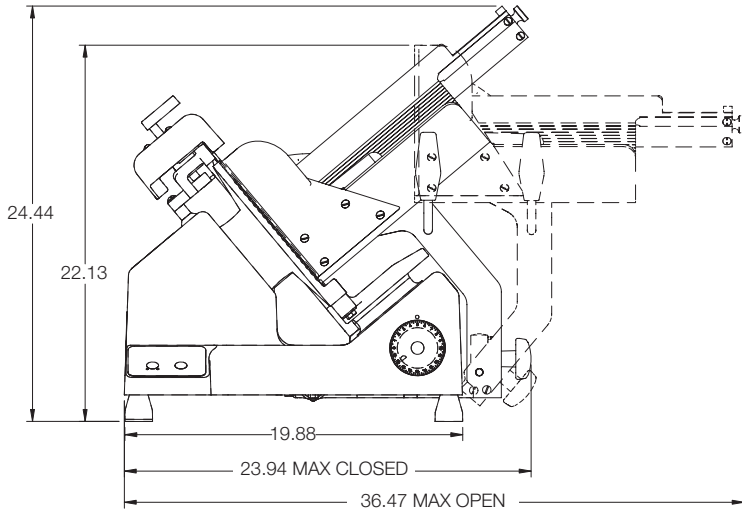

UNIT: Inches

Drawings available through KCL. www.kclcad.com

SPECIFICATIONS

Model	Motor	Volts	Amps	NEMA Plug Type	Drive Type	Slicing Vol. / Day	Cheese Slicing	Blade Diameter	Max Slice	Product Cutting Capacity		
										D (Diameter)	H (Height)	W (Width)
S13	1/2 HP	115-60-1	2	5-15	Poly-V Belt	All Day		13" (33.02 cm)	1-1/8" (2.857 cm)	8" (20.32 cm)	13.75" (35 cm)	11" (27.94 cm)
S13-05	1/2 HP	220-60-1	1	6-15P	Poly-V Belt	All Day		13" (33.02 cm)	1-1/8" (2.857 cm)	8" (20.32 cm)	13.75" (35 cm)	11" (27.94 cm)
S13-07	1/2 HP	220-50-1	1	CEE7/7	Poly-V Belt	All Day		13" (33.02 cm)	1-1/8" (2.857 cm)	8" (20.32 cm)	13.75" (35 cm)	11" (27.94 cm)

Cord & Plug: Attached 7 ft. flexible 3-wire cord with molded plug fits a grounded receptacle. *Please specify desired plug configuration when ordering.*

DIMENSIONS | SHIPPING INFORMATION

Reinforced carton for shipping. The weight and dimensions of this reinforced carton are included below and may vary from shipment to shipment.

Shipped on a pallet. Freight class 85.

Model	Max Overall Dimensions	Net Weight	Shipping Dimensions	Shipping Weight
S13	36.47" W x 29.56" D x 25.51" H (92.63 cm x 75.08 cm x 64.8 cm)	114 lbs. (51.71 kg)	31.5" W x 31.5" D x 31.5" H (80 cm x 80 cm x 80 cm)	135 lbs. (61.24 kg)

FACTORY INSTALLED OPTIONS:

- NEW!** KNIFE-RMV - Removable Knife includes removal tool
- NEW!** CARRIAGE-RMV - Removable Carriage
- FRZN - Serrated knife in lieu of standard knife and additional modifications
- CORR - Correctional Package
- MEATROOM - High moisture application (w/ stainless steel knife)
- SSK - Stainless steel knife in lieu of Carbon Steel

OPTIONAL ACCESSORIES:

- S-FENCE - Food Fence
- S-VEGHOP - Vegetable Hopper
- SC-LARGE - Slicer Cover
- S-SLAWTRAY - Slaw Tray
- S-LEGS - 2.5" Extension Legs
- S-XDSLML - Extended Warranty



KNIFE-RMV



CARRIAGE-RMV

Constructed of anodized aluminum with built-in control panel. 1/2 HP motor with overload protection and 13" hardened steel knife. Patent-pending indexing system with slice thickness adjustment up to 1-1/8". Top mounted removable sharpener with synthetic diamond stone wheel and plate. Tilting carriage accommodates up to 13.75" H, 8" dia., 11" W large products. Slicer is ETL listed. No Voltage Release and Knife Cover Interlock. Two year parts and labor slicer warranty, lifetime warranty on sharpening stones.