



Specifications

F.O.B Sedalia, Missouri 65301



DPAH-3-CP

OPTIONS:

- Beaded 12" x 20" openings
- Tray shelves
- Fluorescent lights
- Incandescent bullet lights
- Legs in lieu of casters
- Adapter bars
- False bottom
- Body latches
- Tray shelf on end

AGENCY LISTINGS:



DUKE MANUFACTURING CO.
 2305 N. Broadway
 St. Louis, MO 63102

800.735.3853 Toll Free
314.231.5074 Fax
www.dukemfg.com

SS-DM-00043-EMB-05

Approval Stamp(s):

PRODUCT INFORMATION:

PROJECT: _____

ITEM: _____

QUANTITY: _____

MODEL:

Econo Mate™ Buffet Units Cold Pan - Ice Cooled

- DPAH-2-CP/OPAH-2-CP** Portable (floor models) 2-well cold pan
- DPAH-3-CP/OPAH-3-CP** Portable (floor models) 3-well cold pan
- DPAH-4-CP/OPAH-4-CP** Portable (floor models) 4-well cold pan
- TAH-2-CP** Table Top - 2 cold pan wells
- TAH-3-CP** Table Top - 3 cold pan wells
- TAH-4-CP** Table Top - 4 cold pan wells

BODY:

- Heavy gauge paint grip steel
- Choice of (12) powder coat paint colors (must choose one)

<input type="checkbox"/> #217105 - Bright White	<input type="checkbox"/> #217103 - Natural Almond
<input type="checkbox"/> #217150 - Orange Red	<input type="checkbox"/> #217154 - Racing Red
<input type="checkbox"/> #217107 - Hollyberry Red	<input type="checkbox"/> #217120 - Sky Blue
<input type="checkbox"/> #217127 - Fence Green	<input type="checkbox"/> #217152 - Stone Gray
<input type="checkbox"/> #217102 - Duke Silver	<input type="checkbox"/> #217113 - Brown Kickplate
<input type="checkbox"/> #217101 - Semi Gloss Black	<input type="checkbox"/> #217125 - Textured Black
- Heavy gauge; 300 Series stainless steel top
- Clear plexiglass canopy, with black powder coat steel brackets with end enclosures

BASES:

- Choice of
 - Open base - O
 - Closed base - D
 - Table Top - T
- 5" NSF listed black swivel casters, 2 with locks

COLD PAN:

- 5" deep liner, sloping to 1" brass drain and plug
- Fully insulated stainless steel pan
- Width of 19-7/8"

SHORT FORM SPECIFICATIONS:

Duke Econo Mate Cold Pan Units - Ice Cooled. Portable Buffet with heavy gauge painted steel bodies, open or closed style, with 300 series stainless steel heavy gauge tops, sectional 5"D ice cooled s/s cold pans w/ drain, enclosed steel base w/powder coat finish & sliding doors, clear acrylic canopy, 5" NSF approved black casters, 2 w/ locks, 6' cord & plug. Table top models available.

Econo-Mate®

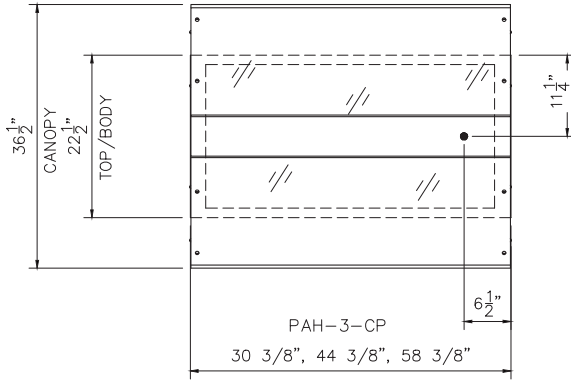

TOP VIEW

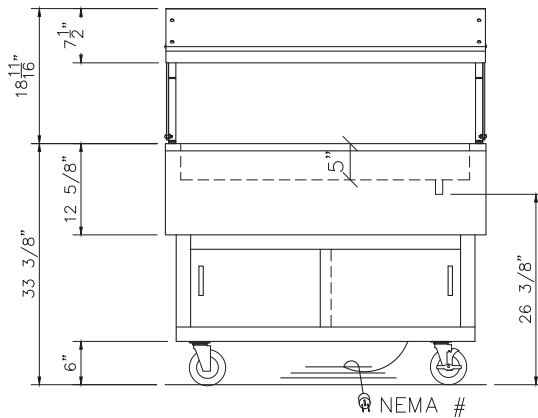

FRONT VIEW

Econo Mate Buffet Units Cold Pan - Ice Cooled

- DPAH-2-CP/OPAH-2-CP** Portable (floor models) 2-well cold pan
- DPAH-3-CP/OPAH-3-CP** Portable (floor models) 3-well cold pan
- DPAH-4-CP/OPAH-4-CP** Portable (floor models) 4-well cold pan
- TAH-2-CP** Table Top - 2 cold pan wells
- TAH-3-CP** Table Top - 3 cold pan wells
- TAH-4-CP** Table Top - 4 cold pan wells

LEGEND	
•	- DRAIN LOCATION
When ordering storage bases, precede model number with "O" for Open Base or "D" for closed base with doors. Example: OPAH-2-BC for open base unit.	

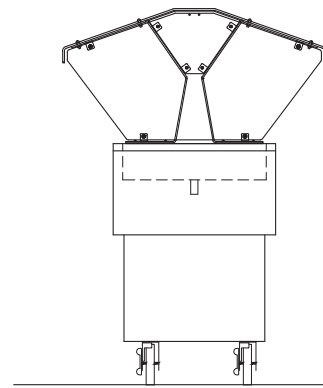

SIDE VIEW

DIMENSIONS:

Portable Ice Cooled Cold Pan Units

FREIGHT CLASS: 100

Model	Length		Width		Height		Liner Dimensions in.			Cube ft. Crated	Weight	
	in.	cm	in.	cm.	in.	cm	L	W	D		lbs.	kg
DPAH-2-CP/OPAH-2-CP	30-3/8	77.2	22-1/2	57.2	33-3/8	84.8	26	19-7/8	5	23.1	204/200	92.7/90.9
DPAH-3-CP/OPAH-3-CP	44-3/8	112.8	22-1/2	57.2	33-3/8	84.8	40	19-7/8	5	32.0	261/257	118.6/116.8
DPAH-4-CP/OPAH-4-CP	58-3/8	148.3	22-1/2	57.2	33-3/8	84.8	54	19-7/8	5	40.9	282/278	128.2/126.4

Table Top Ice Cooled Cold Pan Units

FREIGHT CLASS: 100

Model	Length		Width		Height		Liner Dimensions in.			Cube ft. Crated	Weight	
	in.	cm	in.	cm.	in.	cm	L	W	D		lbs.	kg
TAH-2-CP	30-3/8	77.2	22-1/2	57.2	13-5/8	34.7	26	19-7/8	5	12.1	142	64.6
TAH-3-CP	44-3/8	112.8	22-1/2	57.2	13-5/8	34.7	40	19-7/8	5	16.7	183	83.2
TAH-4-CP	58-3/8	148.3	22-1/2	57.2	13-5/8	34.7	54	19-7/8	5	21.4	208	94.6

*NOTE: Canopy adds 12-3/4" (32.4) to width and 20" (50.8 cm) to height.



DUKE MANUFACTURING CO.

2305 N. Broadway
St. Louis, MO 63102

800.735.3853 Toll Free
800.231.1130 In Missouri
314.231.5074 Fax
www.dukemfg.com

Specification subject to change