

CONNERTON

American Made Since 1936

Model CN36 Restaurant Gas Range

Date:

Project:

Quantity:



Connerton cooking systems restaurant range family of products feature stainless steel fronts, sides, and riser with removable high shelf. Performance profile is driven by 28,000 Btu open burners via energy saving flashtubes versus individual pilot lights.

Heavy duty, cast iron burner grates include flame enhancing bowl configuration. CN model griddles are finely polished 1" thick steel. The CN ranges include full depth 'bake and roast' ovens of 35,000 Btu's and incorporate a burner-baffle match for unique heat distribution supporting the operator's need to either bake or roast.

STANDARD FEATURES

- Stainless Steel front, sides, riser, lift-off high shelf
- 6" stainless steel adjustable legs
- Six open top burners of 28,000 Btu's each
- Energy saving flash tube pilot systems (i.e. one pilot per two burners)
- Heavy Duty cast iron grates
- Full depth, pull out crumb tray
- Bake n' Roast oven @ 35,000 Btu's; fits full sized sheet pans
- One oven rack with three positions
- One year parts & labor warranty

ACCESSORIES

- Casters (set of four)
- Extra oven rack
- 12" stainless steel stub back

OPTIONS

- 12" wide x 1" thick griddle
- 24" wide x 1" thick griddle



Connerton

11990 Rivera Rd., Santa Fe Springs, CA 90670
Telephone: (714) 547-9218 Fax: (714) 547-1969
www.connertoncooking.com

Model CN36 GAS Range

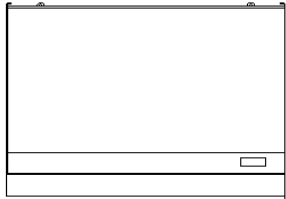
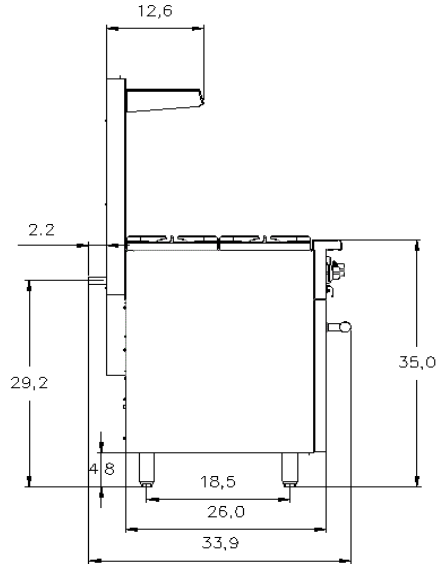
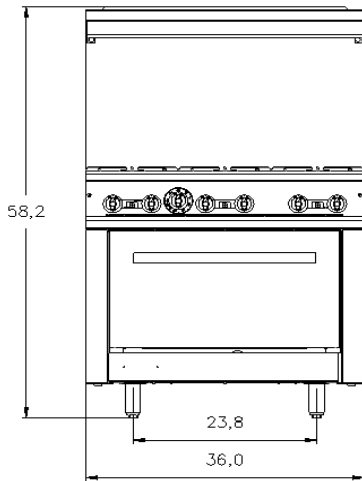

CN36-36G

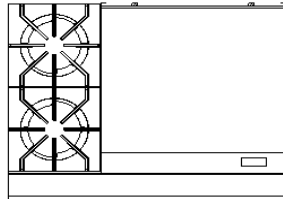

CN36-2-24G

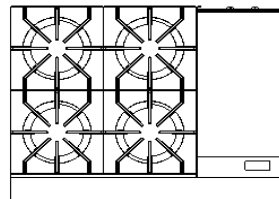

CN36-4-12G

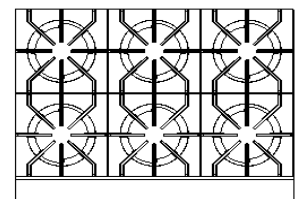

CN36-6

INSTALLATION INSTRUCTIONS

1. A pressure regulator sized for this unit is included.
Natural gas 5.0" W.C., propane gas 10.0" W.C.
2. Gas line connecting to range must be 3/4" or larger. If flexible connectors are used, the inside diameter must be 3/4" or larger.
3. An adequate ventilation system is required for Commercial cooking equipment. Information may be obtained by writing to the National Fire Protection Association, 1 Batterymarch Park, Quincy, MA 02269, www.NFPA.org. When writing, refer to NFPA No. 96.
4. These units are manufactured for installation in accordance ANSZ223.1A (latest edition), National Fuel Gas Code. Copies may be obtained from American Gas Association, 400 N Capital St. NW, Washington, DC 20001, www.AGA.org.

- | | | |
|---------------------------------|---------|-------|
| 5. Clearances | Rear | Sides |
| Combustible | 6" | 10" |
| Standard Oven Non-combustible | 0" | 0" |
| Convection Oven Non-combustible | Min. 4" | 0" |
6. For proper combustion, install equipment on adjustable legs or casters provided with unit.

**Specify type of gas when ordering.
Specify altitude when above 2,000 feet**



Connerton reserves the right, without notice, to make changes and revisions in product specifications, materials and design, which in our opinion will provide better performance, durability and efficiency.

Connerton

Telephone: (714) 547-9218

Fax: (714) 547-1969