

THE
MALT
HANDBOOK



CONTENTS

05 CRISP

- 05 Introduction To Crisp
 - 06 Crisp History
 - 07 The Crisp Team
 - 08 Technical Support
 - 09 The Growing Year
 - 10 Maris Otter®: A Norfolk Heirloom
 - 12 Making The Finest Malt
 - 14 Your Guide to a Quality Malt
 - 16 Master Specification Tables
-

23 BASE MALTS

- 24 Finest Maris Otter® Ale Malt
 - 26 Extra Pale Maris Otter® Malt
 - 29 Chevallier® and The Heritage Malt Revival
 - 30 Chevallier® Heritage Malt
 - 32 Best Ale Malt
 - 34 Extra Pale Malt
 - 36 Europils Malt
 - 38 German Pilsen Malt
 - 40 Clear Choice® Malt
 - 42 Clear Choice® Malt Extra Pale
 - 44 Vienna Malt
-

47 COLOURED MALTS

- 48 Amber Malt
- 49 Brown Malt
- 50 Low Colour Chocolate Malt
- 51 Chocolate Malt
- 52 Black Malt
- 53 Roast Barley
- 54 Extra Light Crystal (Crystal 100)
- 55 Light Crystal (Crystal 150)
- 56 Medium Crystal (Crystal 240)
- 57 Dark Crystal (Crystal 400)
- 58 Crystal Rye Malt
- 59 Cara Gold Malt
- 60 Cara Malt

63 SPECIALITY MALTS

- 64 Light Munich Malt
 - 65 Dark Munich Malt
 - 66 Dextrin Malt
 - 67 Wheat Malt
 - 68 Rye Malt
 - 69 Naked Oat Malt
-

70 FLOOR MALT

- 72 N° 19 Maris Otter® Ale Malt
-

74 ORGANIC MALTS

77 NON-MALTED CEREALS

- 78 Torrefied Wheat
 - 79 Flaked Torrefied Barley
 - 80 Flaked Torrefied Maize
 - 81 Flaked Torrefied Rice
 - 82 Flaked Torrefied Oats
-

85 DISTILLING MALT

- 86 Premium Pot Still Malt
 - 87 Peated Pot Still Malt
 - 88 High Diastatic Power (HDP) Malt
-

90 OUR DISTRIBUTION NETWORK

92 PRODUCT PACKAGING

95 RECIPES

123 GET IN TOUCH



When you visit our little part of the world there is a common place in every town and village that brings people together. When the weather is fine and the beer garden is bathed in sunshine, or even when it's wet and cold outside with the fireplace crackling away, we gather in the local pub to celebrate and commiserate with friends and family over a pint of beer.

As the tap is pulled back and the rush of foam enters the glass, that sound makes you anticipate the beautifully presented pint that is to follow. From the first sip, when the hops give way to the rich malt body of a well-crafted beer, we can't help but raise our glass to you, the brewer, whose passion and talent we celebrate right to the bottom of the glass.

We love great beer and without great malt you couldn't do what you do. Within these pages we're proud to present our range of malts that we have crafted and passed to you for your consideration. Use them, play around with them, create new and exciting beers with them and when that tap opens we will be toasting your labour of love.

CHEERS!

CRISP HISTORY



Frederick Edgar Smith

Crisp started out in 1870 when two brothers, Frederick and George Smith, recognised the unmatched quality of the barley in their home county of Norfolk and established a maltings at Great Ryburgh. Our Norfolk maltings is still our home and from our traditional floors, modern

maltings and new Speciality Malt Plant we produce a huge range of malts for imaginative brewers, not just in the UK but all over the world. Wherever there is craft beer you'll find us.

Through our wholesale partners here in the UK and by direct delivery, we can fulfil any size of order from a few kilos to bulk truck loads. No matter what size your brewery, our team of brewers and maltsters will work with you to provide the technical back up to get the very best from our premium grains.



George Jacobs-Smith

THE CRISP TEAM

Our team may be a collection of maltsters, brewers, distillers, engineers, food scientists, lab techs and logistics specialists, but the one thing that unites us is a love of great beer and a desire to produce the great malt for your brewing needs. Here they are...



TECHNICAL SUPPORT

Our central lab in Norfolk is where all of our quality control takes place. We analyse every load of incoming barley, and every batch of malt we make, to ensure consistency and quality. These same services can be utilised by you to improve your processes or troubleshoot problems in the brewhouse. Grist analysis, spent grains analysis, micromalting, benchtop mashing and enzyme analysis are just some of the lab services we offer.



Our technical brewing team, Carl and Colin, have over 50 years in the industry between them and can assist with brewhouse optimisation, process improvement and recipe development. If you're starting up then we are more than happy to come along and help brew a batch to set you on the right path. We've helped countless customers fix issues and we are always here at the end of the phone or email to advise you on brewing techniques and best practice. We are constantly learning with our customers and we love to pass that knowledge along.

THE GROWING YEAR

Based in East Anglia, we are constantly reminded of the role of farming in our local community. If you've visited us in Norfolk, we're sure you'll have experienced being stuck behind tractors and combine harvesters as they roll slowly down the narrow roads of the county; a reminder of the important role of agriculture in our corner of the UK.

In winter the fields are covered in a carpet of Maris Otter®, just itching to get going once there is enough heat and light in the day. By spring the stalks have started to form and the barley proudly rises out of the ground throwing out its tillers that will eventually go to seed. Finally, there are those summer weeks when the whole of Norfolk seems to be covered in a shimmering sea of golden barley, ready to be harvested, dried and stored for another year of malting.

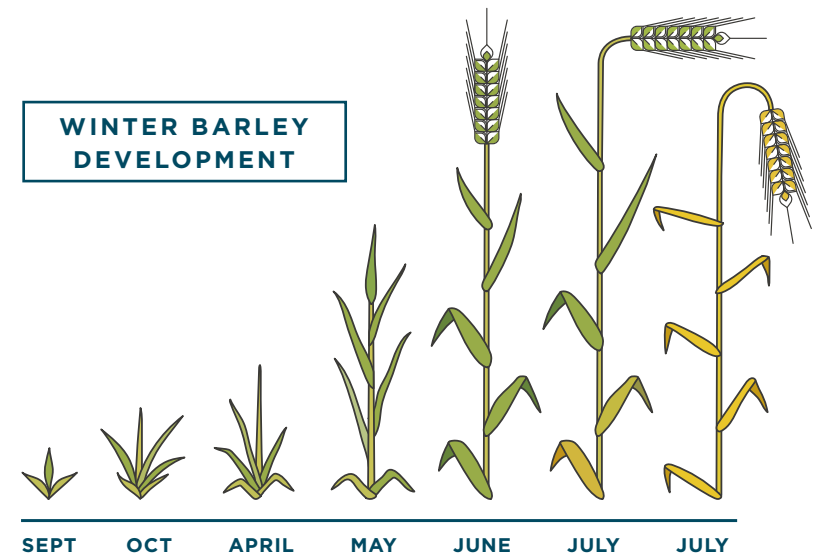

MARIS OTTER® A NORFOLK HEIRLOOM

Tony Bambridge has been farming Maris Otter® on four hundred acres of North Norfolk land for 40 years, just 18 miles from our maltings. We asked him what makes Maris Otter® so special to this part of the world.



Tony Bambridge

“Norfolk, and especially this area in the north close to the sea, is one of the best places for growing malting barley in the world. We jut out into the North Sea which means we get a maritime climate that regulates the summer temperatures and provides moist air. This ensures a long, slow maturation of the barley with no intense heat. The other factor that makes for superb barley is the light, sandy, free draining soil. This means the soil doesn’t hold onto nitrogen and results in a very low protein crop. We also have lots of naturally high levels of phosphate which aids in plant health.”

“We work with Crisp, and our merchant Banhams, because of the personal relationships we’ve built up over the years. It feels like very much a team effort. We are proud of the fact that the crop

is local, has low food miles and is a named barley that goes into named products. We produce other crops and we don’t know where they will eventually end up, but with our Maris Otter® we can see the beers in the pub and that is rewarding. All the better when we occasionally get to drink some of it!”

“A lot of care and attention goes into growing Maris Otter®. It’s not easy and the farm yield is poor compared to other malting barleys but those relationships, the ability of this terroir to produce consistently superior grain year in year out means we will be growing Maris Otter® for a long time to come. “

“
Norfolk, and especially this area in the north close to the sea, is one of the best places for growing malting barley in the world.

MAKING THE FINEST MALT

TRADITIONAL FLOOR MALTING

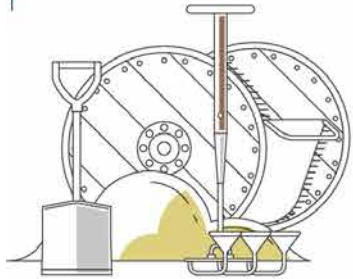

STAGE ONE STEEPING

A batch of barley is selected and hydrated using up to three immersions in fresh water. We adjust the temperatures and the timing of wet and dry stages depending on the type and maturity of the barley and the final specification of malt we want.

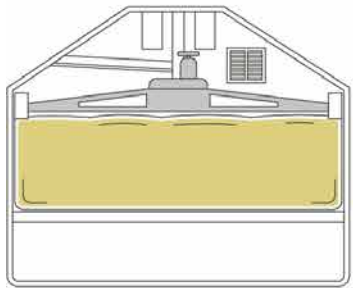

MODERN MALTING

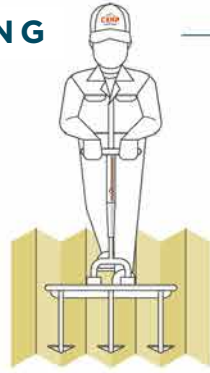

STAGE TWO GERMINATION

The sprouting barley is moved to a malting floor or vessel and allowed to grow for four to five days. The moisture and temperatures are controlled to a recipe we have tailored for the type of malt. This process naturally modifies the barley structure breaking down cell walls and protein, releasing starch and producing enzymes. During germination the 'green malt' must be turned to stop the rootlets matting.

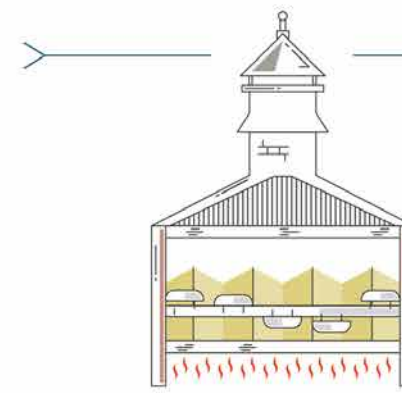
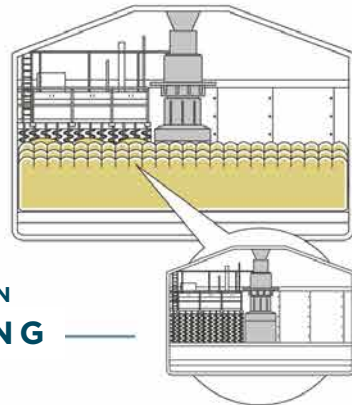

STAGE THREE KILNING

Germination is stopped by gently drying on a kiln for up to three days. We use a stepped programme of temperatures and varying airflows to protect the enzymes within the grain and create the colour and flavour we are looking for. The rootlets are removed and the final malt is back to looking a little like barley but inside it now has all the extract, enzymes and nutrients essential to making great beer and whisky.

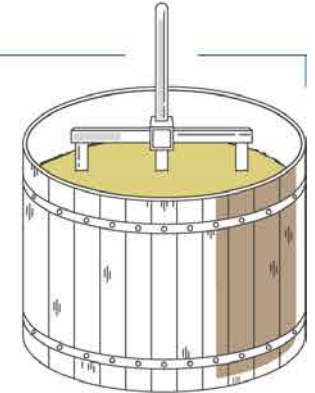
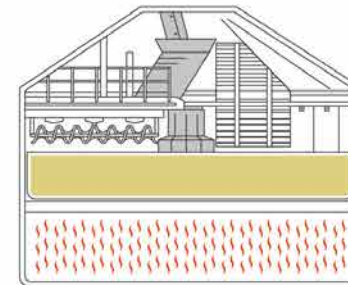

AT THE BREWERY MASHING

The malt is crushed at the maltings or at the brewery and then mashed to convert the malt starch into sugars to create the wort. With the infinite number of malt and cereal combinations this is the starting point for a myriad of different flavours, colours and styles.

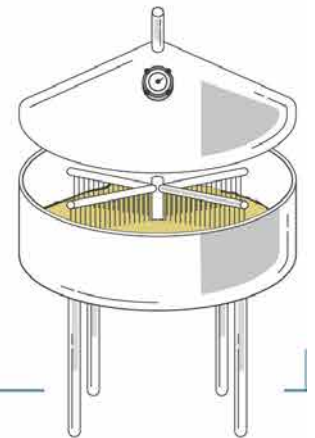

YOUR GUIDE TO A QUALITY MALT



Every Crisp customer has access to the Certificate of Analysis (COA) for the malt they have ordered.

This handy guide should help you get what you need from your COA.

Also view your COA online or by scanning the QR Code using our Crisp App!



SOLUBLE NITROGEN

The nitrogen (protein) that has been broken down in the malting process. Soluble nitrogen will aid head retention, provide yeast nutrition and add body and mouthfeel to the beer.



SOLUBLE NITROGEN RATIO (SNR)

The ratio of total to soluble nitrogen and gives a very good indication of the modification of the malt. We are looking for 38-42 for ale malt.



FRIABILITY

A measure of how easily the malt will mill. It is also a good measure of the extent of cell wall modification of the barley. A minimum of 85% is expected. If friability changes then you may need to adjust your milling regime.



DIASTATIC POWER

A measure of some of the starch degrading enzyme activity in the grain; the higher the DP the greater the conversion rate from starch to fermentable sugar. A minimum figure of 40 IoB is expected for base malts. If you're using lots of speciality malt or un-malted cereals then a higher DP may be beneficial to conversion.

MOISTURE

This measures how much water there is in the malt. A higher kilned malt will have a lower moisture. Typical maximum is 3.5% for Pale Malt and 4.5% for Extra Pale Malts. Remember to store grains in a dry environment for maximum shelf life.

TOTAL NITROGEN

(DRY BASIS)
An important measure of the nitrogen (protein) in the grain. The higher the protein, the lower the extract and vice versa. High protein will cause issues with clarity and fermentation. Ale malt should be around 1.35-1.55% and up to 1.75% for lager malt.

EXTRACT

(AS IS)
This is the amount of soluble material within the malt. The IoB method mashes the grain for 60 min at 65°C so it strongly approximates the infusion method of brewing. The EBC mashing method uses a stepped temperature programme so is more representative of a typical continental mashing process. This is the extract value used in calculations in the brewhouse.

(DRY BASIS)
This expression of extract takes into account the moisture content of the malt and allows direct comparison of extract between different malts. Base malts typically have a minimum 305 L°/kg extract dry basis.

CRISP MALT, GREAT RYBURGH, FAKENHAM, NORFOLK, NR21 7AS

Analysis of Batch

Crushed Maris Otter® Ale Malt

Customer:					
Batch Number:	SS14580	Your Reference:			
Bag Reference:	SS14580	Our Order No:			
Parameters		Min	Target	Max	Analysis
Moisture	%			3.5	3.5
IOB Extract 0.7mm as is basis	l deg/kg				301
IOB Extract 0.7mm dry basis	l deg/kg	305			312
IOB Colour Visual	deg EBC	5.0		6.5	5.0
Total Nitrogen dry basis	%	1.35		1.58	1.38
IOB Total Soluble Nitrogen dry basis	%				0.99
IOB Soluble Nitrogen Ratio	%	39.0		43.0	42.8
Friability	%	85.0			98.3
Homogeneity	%	95.0			99.7
Diastatic Power as is basis	deg IOB	40		85	59
Best Before:	31/12/2020				

CRAFT BREWING PRODUCT RANGE			TYPICAL IoB ANALYSIS								ATTRIBUTES	
PRODUCT NAME	WHOLE	CRUSHED	MOISTURE MAX	EXTRACT TYPICAL	COLOUR RANGE		TOTAL NITROGEN RANGE		SNR RANGE			
BASE MALTS												
FINEST MARIS OTTER® ALE MALT	✓	✓	3.5	308	5.0	7.0	1.30	1.60	38	43	The consistently reliable Maris Otter® continues to provide the qualities expected by the brewer	
EXTRA PALE MARIS OTTER® MALT	✓	✓	4.5	308	2.5	3.5	1.30	1.60	38	43	Lower colour version of Maris Otter® Ale Malt suitable for lager and golden ale brewing	
CHEVALLIER® HERITAGE MALT	✓	✓	3.5	300	5.0	7.0	1.80		45		First malted in the 1820s, Chevallier® provides rich malty flavours to heritage and modern beer styles	
BEST ALE MALT	✓	✓	3.5	310	5.0	7.0	1.40	1.65	38	43	The principal ingredient in cask and bottled ales, porters and stouts	
EXTRA PALE MALT	✓	✓	4.5	310	2.5	3.5	1.40	1.65	38	43	Lower colour version of Best Ale Malt suitable for lager and golden ale brewing	
EUROPILS MALT	✓	✓	4.5	308	2.5	3.5	1.50	1.75	33	37	Traditional European-style malt suitable for all pilsner types	
GERMAN PILSEN MALT	✓	✓	4.5	302	3.0	4.0	1.52	1.90	32	38	Pilsen Malt produced at our Tivoli maltings in Hamburg suitable for continental-style brewing processes	
CLEAR CHOICE MALT® ALE	✓	✓	4.0	308	5.5	7.5	1.45	1.80	37	46	Free from polyphenols thus reducing the risk of haze formation, increasing shelf life and reducing cold conditioning costs	
CLEAR CHOICE MALT® EXTRA PALE	✓	✓	4.5	308	2.5	4.0	1.45	1.80	37	46		
VIENNA MALT	✓	✓	4.5	302	5.0	9.0	1.40	1.65			Vienna Malt is produced on a conventional kiln and provides a light golden hue	
COLOURED MALTS												
AMBER MALT	✓	✓	2.0	275	55	75					Gives a dry, biscuity flavour to ales and provides red hue	
BROWN MALT	✓	✓	2.0	275	110	135					Provides a smoothness to porters and other dark beers	
LOW COLOUR CHOCOLATE MALT	✓	✓	2.0	272	400	600					A lighter version of our Chocolate Malt	
CHOCOLATE MALT	✓	✓	2.0	272	850	1050					Gives dry, toasty flavours to rich, dark beers	
BLACK MALT	✓	✓	2.0	270	1100	1400					Used to provide full, rich flavour to range of darker beer styles	
ROAST BARLEY	✓	✓	2.0	270	1100	1400					Provides characteristic sharp, bitter flavour to stouts and some porters	
EXTRA LIGHT CRYSTAL (CRYSTAL 100)	✓	✓	5.5	271	90	110					Provides sweet flavours and a light golden hue	
LIGHT CRYSTAL (CRYSTAL 150)	✓	✓	5.0	271	145	165					Provides sweet, caramel flavours and a golden hue	
MEDIUM CRYSTAL (CRYSTAL 240)	✓	✓	3.5	270	225	265					Used to adjust colour and flavour of ales, giving deep golden to red hues	
DARK CRYSTAL (CRYSTAL 400)	✓	✓	3.0	270	380	435					Used to adjust colour and flavour of ales, giving red to deep red hues	
CRYSTAL RYE MALT	✓	✓	5.0	270	200	400					Used to provide colour and spicy flavour	
CARA GOLD MALT	✓	✓	6.5	280	12	16					Provides the opportunity to add body to beer with little impact on colour	
CARA MALT	✓	✓	6.0	277	23	32					Used to adjust colour and flavour of light coloured beers	
SPECIALITY MALTS												
LIGHT MUNICH MALT	✓	✓	4.5	299	15	25	1.60	1.80				
DARK MUNICH MALT	✓	✓	4.5	299	35	45	1.60	1.80			Vienna and Munich malts are produced on a conventional kiln and provide light golden through to orange hues	
DEXTRIN MALT	✓	✓	7.0	300	2.0	3.0	1.40	2.00	26	35	Used to provide extra body to beer and to improve head retention	
WHEAT MALT	✓	✓	6.5	320	2.5	5.0	2.20		38	46	Even when used in small quantities will improve foam and head retention in all beers	
RYE MALT	✓	✓	6.0	328	12.0	32.0	1.60		37	46	Provides spicy complexity to ales and lagers	
NAKED OAT MALT	✓	✓	5.5	245	2.0	7.0	2.70		11	14	Used in oatmeal stout, but can also provide smooth finish to ales	
FLOOR MALTS	✓	✓									A range of bespoke ale, lager and distilling malts produced in our historic N° 19 floor maltings®	
ORGANIC MALTS												
ORGANIC ALE MALT	✓	✓	4.0	308	4.5	7.0	1.70		37	44		
ORGANIC EXTRA PALE MALT	✓	✓	4.5	308	2.5	4.0	1.70		37	44	Malts produced from organic barley with full supply-chain traceability guaranteed	
ORGANIC CRYSTAL	✓	✓	5.0	270	150	170						
NON-MALTED CEREALS												
TORREFIED WHEAT	✓	✓	10.0	310							Pre-cooked, non-malted cereals provide the brewer with the opportunity for product differentiation. Flaked products can be added directly to the mash without the need for milling.	
TORREFIED BARLEY	✓	✓	8.0	308								
FLAKED TORREFIED BARLEY		(Flaked)	10.0	308								
FLAKED TORREFIED MAIZE		(Flaked)	8.5	328								
FLAKED TORREFIED RICE		(Flaked)	8.5	305								
FLAKED TORREFIED OATS		(Flaked)	11.0	292								

CRAFT BREWING PRODUCT RANGE			TYPICAL EBC ANALYSIS								ATTRIBUTES	
PRODUCT NAME	WHOLE	CRUSHED	MOISTURE MAX	EXTRACT TYPICAL	COLOUR RANGE		TOTAL PROTEIN RANGE		KI RANGE			
BASE MALTS												
FINEST MARIS OTTER® ALE MALT	✓	✓	3.5	81.5	5.5	7.5	8.0	10.0	43	48	The consistently reliable Maris Otter® continues to provide the qualities expected by the brewer	
EXTRA PALE MARIS OTTER® MALT	✓	✓	4.5	81.5	2.8	4.0	8.0	10.0	43	48	Lower colour version of Maris Otter® Ale Malt suitable for lager and golden ale brewing	
CHEVALLIER® HERITAGE MALT	✓	✓	3.5	80.0	5.5	7.5	11.3		50		First malted in the 1820s, Chevallier® provides rich malty flavours to heritage and modern beer styles	
BEST ALE MALT	✓	✓	3.5	82.0	5.5	7.5	8.8	10.3	43	48	The principal ingredient in cask and bottled ales, porters and stouts	
EXTRA PALE MALT	✓	✓	4.5	82.0	2.8	4.0	8.8	10.3	43	48	Lower colour version of Best Ale Malt suitable for lager and golden ale brewing	
EUROPILS MALT	✓	✓	4.5	81.5	2.8	4.0	9.4	11.0	38	42	Traditional European-style malt suitable for all pilsner types	
GERMAN PILSEN MALT	✓	✓	4.5	81.5	3.5	4.5	9.5	12.0	37	43	Pilsen Malt produced at our Tivoli maltings in Hamburg suitable for continental-style brewing processes	
CLEAR CHOICE MALT® ALE	✓	✓	4.0	81.5	6.5	8.5	9.0	11.3	42	52	Free from polyphenols thus reducing the risk of haze formation, increasing shelf life and reducing cold conditioning costs	
CLEAR CHOICE MALT® EXTRA PALE	✓	✓	4.5	81.5	2.8	4.5	9.0	11.3	42	52		
VIENNA MALT	✓	✓	4.5	80.0	5.5	10.0	8.8	10.3			Vienna Malt is produced on a conventional kiln and provides a light golden hue	
COLOURED MALTS												
AMBER MALT	✓	✓	2.0	73.0	60	85					Gives a dry, biscuity flavour to ales and provides red hue	
BROWN MALT	✓	✓	2.0	73.0	120	150					Provides a smoothness to porters and other dark beers	
LOW COLOUR CHOCOLATE MALT	✓	✓	2.0	72.0	440	660					A lighter version of our Chocolate Malt	
CHOCOLATE MALT	✓	✓	2.0	72.0	930	1155					Gives dry, toasty flavours to rich, dark beers	
BLACK MALT	✓	✓	2.0	71.0	1210	1540					Used to provide full, rich flavour to range of darker beer styles	
ROAST BARLEY	✓	✓	2.0	71.0	1210	1540					Provides characteristic sharp, bitter flavour to stouts and some porters	
EXTRA LIGHT CRYSTAL (CRYSTAL 100)	✓	✓	5.5	72.0	100	120					Provides sweet flavours and a light golden hue	
LIGHT CRYSTAL (CRYSTAL 150)	✓	✓	5.0	72.0	160	180					Provides sweet, caramel flavours and a golden hue	
MEDIUM CRYSTAL (CRYSTAL 240)	✓	✓	3.5	71.0	245	290					Used to adjust colour and flavour of ales, giving deep golden to red hues	
DARK CRYSTAL (CRYSTAL 400)	✓	✓	3.0	71.0	420	480					Used to adjust colour and flavour of ales, giving red to deep red hues	
CRYSTAL RYE MALT	✓	✓	5.0	71.0	220	440					Used to provide colour and spicy flavour	
CARA GOLD MALT	✓	✓	6.5	74.0	13	18					Provides the opportunity to add body to beer with little impact on colour	
CARA MALT	✓	✓	6.0	73.0	25	35					Used to adjust colour and flavour of light coloured beers	
SPECIALITY MALTS												
LIGHT MUNICH MALT	✓	✓	4.5	79.0	16.5	27.5	10.0	11.3			Vienna and Munich malts are produced on a conventional kiln and provide light golden through to orange hues	
DARK MUNICH MALT	✓	✓	4.5	79.0	38	50	10.0	11.3				
DEXTRIN MALT	✓	✓	7.0	80.0	2.2	3.3	8.8	12.5	30	40	Used to provide extra body to beer and to improve head retention	
WHEAT MALT	✓	✓	6.5	84.0	2.8	5.5	12.5		43	52	Even when used in small quantities will improve foam and head retention in all beers	
RYE MALT	✓	✓	6.0	86.5	13	35	10.0		42	52	Provides spicy complexity to ales and lagers	
NAKED OAT MALT	✓	✓	5.5	65.0	2.2	7.8	17.0		14	17	Used in oatmeal stout, but can also provide smooth finish to ales	
FLOOR MALTS	✓	✓									A range of bespoke ale, lager and distilling malts produced in our historic N° 19 floor maltings®	
ORGANIC MALTS												
ORGANIC ALE MALT	✓	✓	4.0	81.5	5.0	7.5	10.6		42	50	Malts produced from organic barley with full supply-chain traceability guaranteed	
ORGANIC EXTRA PALE MALT	✓	✓	4.5	81.5	2.8	4.5	10.6		42	50		
ORGANIC CRYSTAL	✓	✓	5.0	72.0	165	190						
NON-MALTED CEREALS												
TORREFIED WHEAT	✓	✓	10.0	82.0							Pre-cooked, non-malted cereals provide the brewer with the opportunity for product differentiation. Flaked products can be added directly to the mash without the need for milling.	
TORREFIED BARLEY	✓	✓	8.0	81.0								
FLAKED TORREFIED BARLEY		(Flaked)	10.0	81.0								
FLAKED TORREFIED MAIZE		(Flaked)	8.5	86.5								
FLAKED TORREFIED RICE		(Flaked)	8.5	80.5								
FLAKED TORREFIED OATS		(Flaked)	11.0	77.0								

CRAFT BREWING PRODUCT RANGE			TYPICAL ASBC ANALYSIS								ATTRIBUTES	
PRODUCT NAME	WHOLE	CRUSHED	MOISTURE MAX	EXTRACT TYPICAL	COLOUR RANGE		TOTAL PROTEIN RANGE		S/T RANGE			
BASE MALTS												
FINEST MARIS OTTER® ALE MALT	✓	✓	3.5	81.5	2.5	3.3	8.0	10.0	43	48	The consistently reliable Maris Otter® continues to provide the qualities expected by the brewer	
EXTRA PALE MARIS OTTER® MALT	✓	✓	4.5	81.5	1.5	2.0	8.0	10.0	43	48	Lower colour version of Maris Otter® Ale Malt suitable for lager and golden ale brewing	
CHEVALLIER® HERITAGE MALT	✓	✓	3.5	80.0	2.5	3.3	11.3		50		First malted in the 1820s, Chevallier® provides rich malty flavours to heritage and modern beer styles	
BEST ALE MALT	✓	✓	3.5	82.0	2.5	3.3	8.8	10.3	43	48	The principal ingredient in cask and bottled ales, porters and stouts	
EXTRA PALE MALT	✓	✓	4.5	82.0	1.5	2.0	8.8	10.3	43	48	Lower colour version of Best Ale Malt suitable for lager and golden ale brewing	
EUROPILS MALT	✓	✓	4.5	81.5	1.5	2.0	9.4	11.0	38	42	Traditional European-style malt suitable for all pilsner types	
GERMAN PILSEN MALT	✓	✓	4.5	81.5	1.5	2.0	10.0	11.0	38	42	Pilsen Malt produced at our Tivoli maltings in Hamburg suitable for continental-style brewing processes	
CLEAR CHOICE MALT® ALE	✓	✓	4.0	81.5	3.0	4.0	9.0	11.3	42	52	Free from polyphenols thus reducing the risk of haze formation, increasing shelf life and reducing cold conditioning costs	
CLEAR CHOICE MALT® EXTRA PALE	✓	✓	4.5	81.5	1.5	2.2	9.0	11.3	42	52		
VIENNA MALT	✓	✓	4.5	80.0	2.5	4.2	8.8	10.3			Vienna Malt is produced on a conventional kiln and provides a light golden hue	
COLOURED MALTS												
AMBER MALT	✓	✓	2.0	73.0	23.0	85.0					Gives a dry, biscuity flavour to ales and provides red hue	
BROWN MALT	✓	✓	2.0	73.0	45.7	57.0					Provides a smoothness to porters and other dark beers	
LOW COLOUR CHOCOLATE MALT	✓	✓	2.0	72.0	166.5	249.5					A lighter version of our Chocolate Malt	
CHOCOLATE MALT	✓	✓	2.0	72.0	351.5	436.5					Gives dry, toasty flavours to rich, dark beers	
BLACK MALT	✓	✓	2.0	71.0	457.0	582.0					Used to provide full, rich flavour to range of darker beer styles	
ROAST BARLEY	✓	✓	2.0	71.0	457.0	582.0					Provides characteristic sharp, bitter flavour to stouts and some porters	
EXTRA LIGHT CRYSTAL (CRYSTAL 100)	✓	✓	5.5	72.0	38.2	45.7					Provides sweet flavours and a light golden hue	
LIGHT CRYSTAL (CRYSTAL 150)	✓	✓	5.0	72.0	60.8	68.4					Provides sweet, caramel flavours and a golden hue	
MEDIUM CRYSTAL (CRYSTAL 240)	✓	✓	3.5	71.0	93.0	110.0					Used to adjust colour and flavour of ales, giving deep golden to red hues	
DARK CRYSTAL (CRYSTAL 400)	✓	✓	3.0	71.0	159.0	182.0					Used to adjust colour and flavour of ales, giving red to deep red hues	
CRYSTAL RYE MALT	✓	✓	5.0	71.0	83.5	166.5					Used to provide colour and spicy flavour	
CARA GOLD MALT	✓	✓	6.5	74.0	5.4	17.2					Provides the opportunity to add body to beer with little impact on colour	
CARA MALT	✓	✓	6.0	73.0	9.9	13.7					Used to adjust colour and flavour of light coloured beers	
SPECIALITY MALTS												
LIGHT MUNICH MALT	✓	✓	4.5	79.0	6.7	10.8	10.0	11.3				
DARK MUNICH MALT	✓	✓	4.5	79.0	14.8	19.3	10.0	11.3			Vienna and Munich malts are produced on a conventional kiln and provide light golden through to orange hues	
DEXTRIN MALT	✓	✓	7.0	80.0	1.3	1.7	8.8	12.5	30	40	Used to provide extra body to beer and to improve head retention	
WHEAT MALT	✓	✓	6.5	84.0	1.5	2.5	12.5		43	52	Even when used in small quantities will improve foam and head retention in all beers	
RYE MALT	✓	✓	6.0	86.5	5.4	13.7	10.0		42	52	Provides spicy complexity to ales and lagers	
NAKED OAT MALT	✓	✓	5.5	65.0	1.3	3.4	17.0		14	17	Used in oatmeal stout, but can also provide smooth finish to ales	
FLOOR MALTS	✓	✓									A range of bespoke ale, lager and distilling malts produced in our historic N° 19 floor maltings®	
ORGANIC MALTS												
ORGANIC ALE MALT	✓	✓	4.0	81.5	2.3	3.3	10.6		42	50		
ORGANIC EXTRA PALE MALT	✓	✓	4.5	81.5	1.5	2.2	10.6		42	50	Malts produced from organic barley with full supply-chain traceability guaranteed	
ORGANIC CRYSTAL	✓	✓	5.0	72.0	165	190						
NON-MALTED CEREALS												
TORREFIED WHEAT	✓	✓	10.0	82.0							Pre-cooked, non-malted cereals provide the brewer with the opportunity for product differentiation. Flaked products can be added directly to the mash without the need for milling.	
TORREFIED BARLEY	✓	✓	8.0	81.0								
FLAKED TORREFIED BARLEY		(Flaked)	10.0	81.0								
FLAKED TORREFIED MAIZE		(Flaked)	8.5	86.5								
FLAKED TORREFIED RICE		(Flaked)	8.5	80.5								
FLAKED TORREFIED OATS		(Flaked)	11.0	77.0								



BASE MALTS

These are the workhorses of the mash; the ultimate source of your fermentable sugars, enzymes and nitrogenous compounds required for producing excellent beer. They need to deliver these each and every time you brew. Crisp have a wide range of base malts to provide you with a broad palate of flavours to build your beers upon. From the malt forward Maris Otter®, through our Best Ale and authentic German Pils to our honey-sweet Clear Choice®; we've got a range to suit every beer style and brewing method. Try them individually or mix them up to create something unique to you.

Some base malts, including Vienna and Dextrin, are made using the conventional kilning technique as described on pages 12 and 13. Using differing steeping, germination and kilning times and temperatures we can manipulate the flavours and colour formed in the malts.

— FINEST —
MARIS OTTER®
 ALE MALT

TASTING NOTES
 MALTY, SWEET, BISCUIT



COLOUR (IoB)

5.0 – 7.0

BEER STYLES

*Light, dark & strong
 milds, English ales,
 IPAs, stouts, porters,
 barley wines,
 golden ales*

USAGE RATE

Up to 100%

RECIPE

*Crisp English ESB
 See page 112*

Maris Otter® Ale Malt is prized all over the world for the incredibly rich and moreish ales that it helps create. Our brewers tell us it is always flavourful, easy to brew with and returns that characteristic malt body that has made it famous over more than 50 years of barley cultivation.

Bred at PBI in Cambridge by Dr GDH Bell, the variety was taken up by Crisp farmers from the very beginning, since the barley thrives in the chalk soils and moist sea air of the North Norfolk coast.

TYPICAL ANALYSIS

PARAMETER	IoB	EBC	ASBC
MOISTURE	3.5% max	3.5% max	3.5% max
EXTRACT	308 L°/kg	81.5%	81.5%
COLOUR	5.0-7.0 EBC	5.5-7.5 EBC	2.5-3.3 °L
TN/TP	1.30-1.60%	8.0-10.0%	8.0-10.0%
SNR/KI/ST RATIO	38-43	43-48	43-48
DP/DPWK/LINTNER	45 min IoB	140 min WK	50 min °L

—EXTRA PALE—
MARIS OTTER®
 MALT

TASTING NOTES

MALTY, SWEET



COLOUR (IoB)
 2.5 – 3.5

BEER STYLES	USAGE RATE	RECIPE
Blondes, pale ales	Up to 100%	Crisp IPA See page 106

At Crisp we also malt a low colour (Extra Pale) version of the Maris Otter® barley. This was originally developed for low colour beer production in traditional breweries where a higher level of modification is demanded for both efficient extract delivery and good brewhouse performance.

Due to the pale colour this can also be used for light continental styles or even cut with our Europils Malt to form a slight malt base for fuller lager styles.

TYPICAL ANALYSIS

PARAMETER	IoB	EBC	ASBC
MOISTURE	4.5% max	4.5% max	4.5% max
EXTRACT	308 L°/kg	81.5%	81.5%
COLOUR	2.5-3.5 EBC	2.8-4.0 EBC	1.5-2.0 °L
TN/TP	1.30-1.60%	8.0-10.0%	8.0-10.0%
SNR/KI/ST RATIO	38-43	43-48	43-48
DP/DPWK/LINTNER	50 min IoB	150 min WK	55 min °L

CHEVALLIER® AND THE HERITAGE MALT REVIVAL

One day in 1824, a nineteenth century labourer found an ear of barley in his boot and planted the seeds in the farm garden of his employer, the Reverend Dr John Chevallier. They sprouted and grew into such splendid specimens of the cereal that the good doctor embarked on a project to propagate the plants in earnest.

So fine were the grains, so good the malting, and so successful the brewing that the Reverend's barley became the mother-crop for generations of the cereal. For nearly 100 years, Chevallier® was the main barley variety in Britain, loved by maltsters and used by brewers across the nation.

Nearly 200 years later, Crisp is working with New Heritage Barley Ltd to revive and grow Chevallier® barley once again. Every year we produce small batches of this exquisite grain to showcase its uniquely rich and biscuit flavours and aromas.





Alternative malt for Maris Otter® Ale Malt

TASTING NOTES

DEEPLY MALTY,
MARMALADE SWEETNESS



COLOUR (IoB)
5.0 – 7.0

BEER STYLES	USAGE RATE	RECIPE
Golden ales, barley wines, IPAs, DIPAs	80 – 100%*	Crisp Victorian Steampunk Ale See page 108

Crisp Chevallier® is characterised by warm cracker and biscuit aromas with a full flavour. Compared to many modern barleys its aroma and flavour are quite pronounced.

Suitable for any malt-forward ale such as a big robust barley wine. Alternatively, it can be used in modern recipes where there is a need to balance a high bitter hop load such as in a Double India Pale Ale.

**Let the heritage malt come through, go light on specials.*

TYPICAL ANALYSIS

PARAMETER	IoB	EBC	ASBC
MOISTURE	3.5% max	3.5% max	3.5% max
EXTRACT	300 L°/kg	80.0%	80.0%
COLOUR	5.0-7.0 EBC	5.5-7.5 EBC	2.5-3.3 °L
TN/TP	1.80%	11.3%	11.3%
SNR/KI/ST RATIO	45	50	50
DP/DPWK/LINTNER	55 min IoB	150 min WK	60 min °L

BEST ALE MALT

TASTING NOTES

BALANCED MALT
 SWEETNESS



COLOUR (IoB)
 5.0 – 7.0

BEER STYLES

*Light, dark & strong
 milds, English ales,
 IPAs, stouts, porters,
 barley wines*

USAGE RATE

Up to 100%

RECIPE

*Crisp Golden Ale
 See page 105*

Our Best Ale Malt is the workhorse of many a brewery and is at home in a variety of beer styles. The 2-row winter barley varieties that go into our Best Ale have been planted in the light, sandy soils of North Norfolk. We source the lowest nitrogen barley from our farmers.

During malting, high cast moistures and a balance of optimal germination time and temperature results in an even, well modified malt with a rich colour and balanced sweet, malt flavour which is ideally suited to ale brewing.

TYPICAL ANALYSIS

PARAMETER	IoB	EBC	ASBC
MOISTURE	3.5% max	3.5% max	3.5% max
EXTRACT	310 L°/kg	82.0%	82.0%
COLOUR	5.0-7.0 EBC	5.5-7.5 EBC	2.5-3.3 °L
TN/TP	1.40-1.65%	8.8-10.3%	8.8-10.3%
SNR/KI/ST RATIO	38-43	43-48	43-48
DP/DPWK/LINTNER	45 min IoB	140 min WK	50 min °L

EXTRA PALE MALT

TASTING NOTES
 SUBTLE MALT SWEETNESS



COLOUR (IoB)
 2.5 – 3.5

BEER STYLES	USAGE RATE	RECIPE
Golden ales, blondes, lagers, pale ales	Up to 100%	Crisp IPA See page 106

Crisp have developed a low colour Extra Pale Malt for low colour beer styles such as lager, blondes and pale ales. Made from the same barley as our Best Ale Malt you can be assured it is Norfolk born and bred.

It is perfectly suited to the traditional UK brewing style where a single strike temperature is used as the malt has a moderate to high level of modification which gives excellent extract, flavour and run-off.

Use it at 100% for lagers and pale ales or mix in some speciality malts for just about any hop driven beer style.

TYPICAL ANALYSIS

PARAMETER	IoB	EBC	ASBC
MOISTURE	4.5% max	4.5% max	4.5% max
EXTRACT	310 L°/kg	82.0%	82.0%
COLOUR	2.5-3.5 EBC	2.8-4.0 EBC	1.5-2.0 °L
TN/TP	1.40-1.65%	8.8-10.3%	8.8-10.3%
SNR/KI/ST RATIO	38-43	43-48	43-48
DP/DPWK/LINTNER	50 min IoB	145 min WK	55 min °L

EUROPILS MALT

Also known as Lager Malt

TASTING NOTES

SWEET, NON-MALTY



COLOUR (IoB)

2.5 – 3.5

BEER STYLES	USAGE RATE	RECIPE
All lagers & light ales	80 – 100%	Crisp Pre-prohibition Lager See page 98

We take English spring barley with a slightly higher protein than our Best Ale Malt and the subsequent low temperature kilning produces Lager Malt with a sweet but not "malty" character.

Lager malts from continental Europe tend to be higher in protein, have less modification and a lower SNR which means the malt then requires processing in a rising temperature programme. This is the reason that decoction and heated mash vessels are the dominant brewing system on the continent.

However, Europils has been optimised for UK brewing and so it works comfortably in a UK single strike temperature brewery or on a continental system.

TYPICAL ANALYSIS

PARAMETER	IoB	EBC	ASBC
MOISTURE	4.5% max	4.5% max	4.5% max
EXTRACT	308 L°/kg	81.5%	81.5%
COLOUR	2.5-3.5 EBC	2.8-4.0 EBC	1.5-2.0 °L
TN/TP	1.50-1.75%	9.4-11.0%	9.4-11.0%
SNR/KI/ST RATIO	33-37	38-42	38-42
DP/DPWK/LINTNER	60 min IoB	200 min WK	66 min °L

GERMAN PILSEN MALT

TASTING NOTES

SWEET, GRASSY, GRAINY



COLOUR (IoB)
 2.5 – 3.5

BEER STYLES

*Continental
 lager malt*

USAGE RATE

Up to 100%

RECIPE

*Crisp German Pilsner
 See page 97*

At our Hamburg maltings we malt Danish and German spring barley to produce a classic German Pilsen style malt for lager production.

With a high protein content this malt benefits from a rising temperature programme and lautering, but our customers have also used it successfully in traditional UK brewhouses.

The higher molecular weight proteins give excellent head retention and mouthfeel. High levels of speciality malt and non-malted cereals can be used with this malt while maintaining fermentation vigour. This malt can be used in single temperature mashing but you may need to increase finings rates to drop out the additional protein.

TYPICAL ANALYSIS

PARAMETER	IoB	EBC	ASBC
MOISTURE	4.5% max	4.5% max	4.5% max
EXTRACT	302 L°/kg	81.5%	81.5%
COLOUR	3.0-4.0 EBC	3.5-4.5 EBC	1.5-2.0 °L
TN/TP	1.52-1.90%	9.5-12.0%	10.0-11.0%
SNR/KI/ST RATIO	32-38	37-43	38-42
DP/DPWK/LINTNER	65 min IoB	230 min WK	70 min °L



ALE

TASTING NOTES

HONEY MALTY,
 SWEETNESS



COLOUR (IoB)
 5.5 – 7.5

BEER STYLES	USAGE RATE	RECIPE
All ale styles	80 – 100%	Crisp NEIPA See page 107

Clear Choice® is a unique offering from Crisp. Our specially selected barley variety has no proanthocyanidins; these are flavonoid polyphenols that impart astringency and also form chill haze with proteins in the final beer. After fining or filtration, the result is a super clear, shelf stable wort with beautiful honey sweetness.

We also recommend using Clear Choice® for cloudy beers where oxidative darkening of polyphenols is a concern. The clarity benefits of Clear Choice® are not just evident in bottle, can and keg, but also help produce extremely bright cask beer too.

TYPICAL ANALYSIS

PARAMETER	IoB	EBC	ASBC
MOISTURE	4.0% max	4.0% max	4.0% max
EXTRACT	308 L°/kg	81.5%	81.5%
COLOUR	5.5-7.5 EBC	6.5-8.5 EBC	3.0-4.0 °L
TN/TP	1.45-1.80%	9.0-11.3%	9.0-11.3%
SNR/KI/ST RATIO	37-46	42-52	42-52
DP/DPWK/LINTNER	45 min IoB	140 min WK	50 min °L



EXTRA PALE

TASTING NOTES

HONEY SWEETNESS



COLOUR (IoB)
 2.5 – 4.0

BEER STYLES	USAGE RATE	RECIPE
Golden ales & lagers	80 – 100%	Crisp German Kolsch See page 101

This is the low colour version of our Clear Choice® Ale Malt. Kilned to a lower temperature than our regular Clear Choice® results in a lighter colour and a delicate sweetness which acts as the perfect base to build robust IPA hop profiles on.

Since heavily hopped beers can contribute high levels of polyphenol content, by eliminating this from the barley (which typically contributes 80% of polyphenol in a regular beer) we can ensure a malt that will aid in the production of bright, heavily-hopped IPAs.

TYPICAL ANALYSIS

PARAMETER	IoB	EBC	ASBC
MOISTURE	4.5% max	4.5% max	4.5% max
EXTRACT	308 L°/kg	81.5%	81.5%
COLOUR	2.5-4.0 EBC	2.8-4.5 EBC	1.5-2.2 °L
TN/TP	1.45-1.80%	9.0-11.3%	9.0-11.3%
SNR/KI/ST RATIO	37-46	42-52	42-52
DP/DPWK/LINTNER	50 min IoB	150 min WK	55 min °L

VIENNA MALT



TASTING NOTES

SUBTLE MALT SWEETNESS
 & TOAST OR BREAD NOTES

BEER STYLES

Vienna lager, altbier,
 kellerbier, kolsch

USAGE RATE

Up to 100%

RECIPE

Crisp Vienna Lager
 See page 99

In the 1840s English maltsters developed air kilning techniques that would pave the way for light coloured beers. German brewers took this technique back to Vienna and Munich respectively and the malt styles were born.

Our Vienna Malt is made from English 2-row spring barley and is kilned to a slightly higher temperature than our Best Ale Malt. The result is a golden hued wort with a sweet, bread like aroma and flavour. Since it is a conventionally kilned malt, Vienna can be used as a base and is perfect creating its namesake, Vienna lager, in addition to other styles.

TYPICAL ANALYSIS

PARAMETER	IoB	EBC	ASBC
MOISTURE	4.5% max	4.5% max	4.5% max
EXTRACT	302 L°/kg	80.0%	80.0%
COLOUR	5.0-9.0 EBC	5.5-10.0 EBC	2.5-4.2 °L
TN/TP	1.40-1.65%	8.8-10.3%	8.8-10.3%

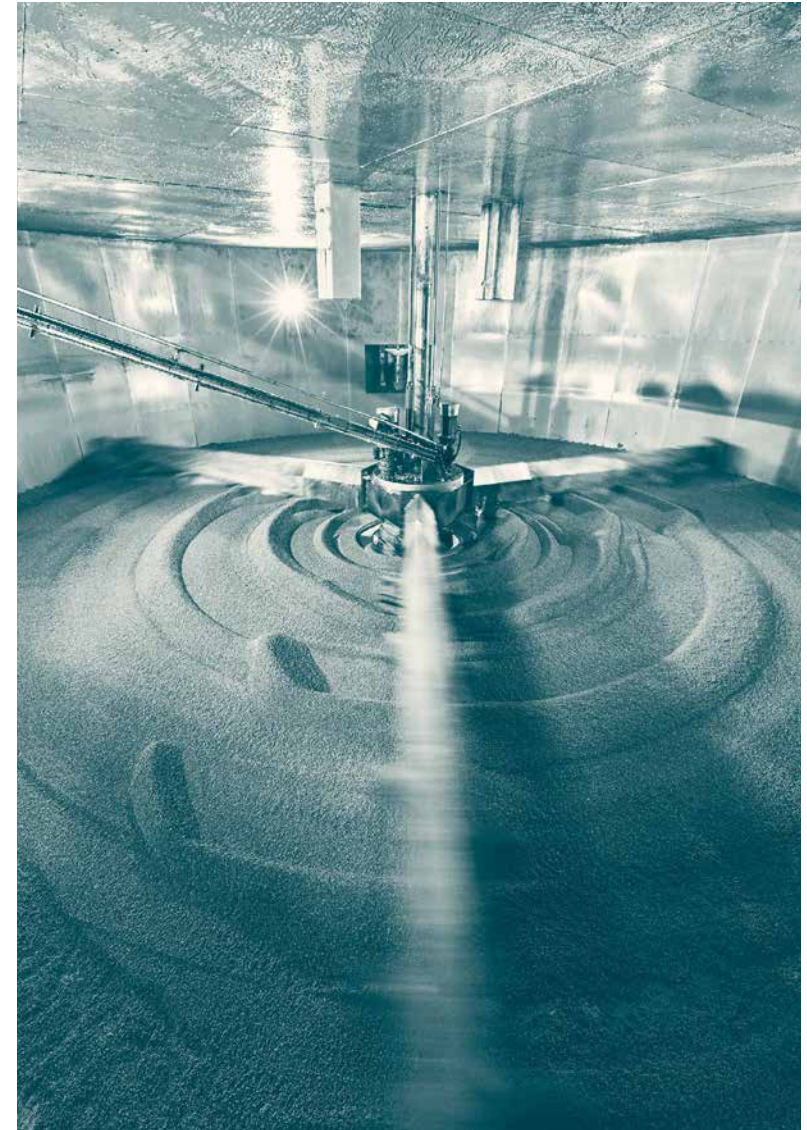



COLOURED MALTS

Leaving the world of conventional kilning behind, we move on to a range of malt where major increases in process temperature are required. The higher colours and stronger flavours of our roasted malts are a result of the same Maillard chemistry that forms the intense aromas and colour of roast coffee, or the delicate biscuit taste in a beautifully baked loaf of bread.

We manage this transformation inside our Speciality Malt Plant by carefully controlling the temperature of the heated surfaces that the grain comes into contact with. Our RevTech speciality malt process is the first of its kind in the UK and gives us unparalleled control over colour formation and flavour profile. It uses less energy than a conventional roasting drum and the grains don't come in contact with combustion gasses due to its all electric nature. The gentle transport of the grain through the column means we can roast just about any cereal, not just malted barley.

AMBER MALT

Also known as Biscuit Malt



TASTING NOTES

DRY, BISCUIT, BREADY,
 SLIGHTLY TOASTED, NO
 RESIDUAL SWEETNESS

BEER STYLES

Old ales, mild ales, brown
 ales, bitters, dark ales

USAGE RATE

Up to 5%

RECIPE

Crisp Amber Ale
 See page 109

This is the palest malt made using a roasting technique. After conventional kilning, the malt is dry and pale in colour hence it is known as “white malt”. It is transferred to our Speciality Malt Plant and passes through the roasting column where the flavour is transformed through the application of heat. The temperatures used through the column determine the colour and flavour of the roasted malt.

Amber Malt is typified by a dry, toasted biscuit finish and can add an amber hue to the beer.

TYPICAL ANALYSIS

PARAMETER	IoB	EBC	ASBC
MOISTURE	2.0% max	2.0% max	2.0% max
EXTRACT	275 L°/kg	73.0%	73.0%
COLOUR	55-75 EBC	60-85 EBC	23-85 °L

BROWN MALT



TASTING NOTES

TOASTED BREAD, DRY,
 NON-SWEET, RICH

BEER STYLES

Old ales, mild ales,
 brown ales, bitters,
 dark ales, porters

USAGE RATE

Up to 5%

RECIPE

Crisp Brown Ale
 See page 117

The next stage up from Amber Malt is our Brown Malt. The colour is produced in the same manner as Amber, but is roasted for that bit longer to give a nutty roast dryness with a light brown hue, perfect for brown ales and milds.

Remember that when assessing roasted malts, it is the resultant colour and flavour of the wort and beer that is important rather than the colour of the outer barley husk of the malt in your hand.

Different varieties of barley may give roasted malts with differing husk colour, but will produce wort with the expected colour and flavour when mashed.

TYPICAL ANALYSIS

PARAMETER	IoB	EBC	ASBC
MOISTURE	2.0% max	2.0% max	2.0% max
EXTRACT	275 L°/kg	73.0%	73.0%
COLOUR	110-135 EBC	120-150 EBC	45.7-57.0 °L

LOW COLOUR CHOCOLATE MALT



TASTING NOTES
 SUBTLE CHOCOLATE, COFFEE
 AROMAS & COLOUR

BEER STYLES	USAGE RATE	RECIPE
Stouts, porters, strong mild	Up to 5%	Crisp Dark Mild See page 114

Another step up in colour into the chocolate range, so called because of the flavour it produces in the final beer, not due to the presence of actual chocolate.

Low Colour Chocolate Malt imparts a delicate chocolate aroma and taste much like a mellow cold brew coffee. This malt type lacks the astringency of the more darkly roasted malts.

TYPICAL ANALYSIS

PARAMETER	IoB	EBC	ASBC
MOISTURE	2.0% max	2.0% max	2.0% max
EXTRACT	272 L°/kg	72.0%	72.0%
COLOUR	400-600 EBC	440-660 EBC	166.5-249.5°L

CHOCOLATE MALT



TASTING NOTES
 DEEP CHOCOLATE, COFFEE
 AROMAS & COLOUR

BEER STYLES	USAGE RATE	RECIPE
Stouts, porters, strong mild	Up to 5%	Crisp London Porter See page 118

Chocolate Malt shares many of the characteristics of Black Malt, but because it is roasted for a shorter period of time and to a lower final temperature, it lacks the astringency of Black Malt.

Its main use is in darker beers that require a depth of colour to tend the eye and entice the palate. Chocolate Malt has been used in Irish stout for years and the marriage of Chocolate Malt and Roasted Barley in varying proportions can give rise to a range of flavours from sweet and mellow to acrid and bitter.

TYPICAL ANALYSIS

PARAMETER	IoB	EBC	ASBC
MOISTURE	2.0% max	2.0% max	2.0% max
EXTRACT	272 L°/kg	72.0%	72.0%
COLOUR	850-1050 EBC	930-1155 EBC	351.5-436.5°L

BLACK MALT

Also known as Patent Malt



TASTING NOTES
ROASTED COFFEE,
LIQUORICE, CURRANTS

BEER STYLES

Porters, stouts

USAGE RATE

Up to 3%

RECIPE

*Crisp Imperial Stout
See page 121*

The darkest of our roasted malts. When you need an intensely dark colour for stouts and porters this is an excellent malt to use. Despite its reputation as a highly astringent malt, nothing could be further from the truth. This malt brings with it a roasted character with some bitterness and astringency, but also flavours of currants and berries.

This malt can also be used for the colour adjustment of pale beers either in the mash or by sprinkling on top of the mash at the sparge stage, to impart a ruby hue.

TYPICAL ANALYSIS

PARAMETER	IoB	EBC	ASBC
MOISTURE	2.0% max	2.0% max	2.0% max
EXTRACT	270 L°/kg	71.0%	71.0%
COLOUR	1100-1400 EBC	1210-1540 EBC	457.0-582.0 °L

ROAST BARLEY



TASTING NOTES
ROASTED COFFEE, BURNT/
BITTER FLAVOURS
(AT HIGHER %)

BEER STYLES

Stouts

USAGE RATE

Up to 5%

RECIPE

*Crisp Irish Stout
See page 119*

Roast Barley is our darkest grain and it is made from unmalted barley. The colour produced can be almost opaque and the flavour is similar to a dark, bitter roast coffee. In stouts a combination of Chocolate, Black Malt and Roast Barley gives excellent complexity and balance.

Remember that these dark grains will have an acidifying effect on the mash, so ensure your salts have been adjusted adequately.

TYPICAL ANALYSIS

PARAMETER	IoB	EBC	ASBC
MOISTURE	2.0% max	2.0% max	2.0% max
EXTRACT	270 L°/kg	71.0%	71.0%
COLOUR	1100-1400 EBC	1210-1540 EBC	457.0-582.0 °L

EXTRA LIGHT CRYSTAL (CRYSTAL 100)



TASTING NOTES
 SUBTLE CARAMEL FLAVOUR

BEER STYLES	USAGE RATE	RECIPE
Milds, bitters, best bitters	Up to 10%	Crisp Mild See page 113

Crystal and Cara Malts are so named for the caramelisation and crystallization of the sugars present in the barley kernel. We take green malt from germination and by applying heat while maintaining the moisture content we are able to liquify the endosperm of the barley, transforming the starch into sugars. Heat is then applied and the caramelisation begins.

In the case of Crystal Malts, when the endosperm cools, sugar crystals are formed. When you cut across the grain the glassy sheen of crystalized sugar can be seen.

Each Crystal Malt imparts a clean, nutty, caramel-like sweetness to your beers. Extra Light Crystal gives a subtle caramel flavour.

TYPICAL ANALYSIS

PARAMETER	IoB	EBC	ASBC
MOISTURE	5.5% max	5.5% max	5.5% max
EXTRACT	271 L°/kg	72.0%	72.0%
COLOUR	90-110 EBC	100-120 EBC	38.2-45.7 °L

LIGHT CRYSTAL (CRYSTAL 150)



TASTING NOTES
 INTENSE CARAMEL FLAVOUR

BEER STYLES	USAGE RATE	RECIPE
Bitters, best bitters, milds	Up to 10%	Crisp Best Bitter See page 111

To make Light Crystal we increase the temperature further and the endosperm darkens and flavours develop further. Think of Crystal Malts like you would make caramel at home. With Light Crystal the crystalised sugars present imparts an intense caramel flavour. Light Crystal will also impart a reddish hue to the beer and it works very well in Bitters and Ruby beers.

The number after the word Crystal refers to the EBC colour of the malt if you mashed at 100% of the grain bill. To get a rough conversion to Lovibond, just divide by two.

TYPICAL ANALYSIS

PARAMETER	IoB	EBC	ASBC
MOISTURE	5.0% max	5% max	5% max
EXTRACT	271 L°/kg	72.0%	72.0%
COLOUR	145-165 EBC	160-180 EBC	60.8-68.4 °L

MEDIUM CRYSTAL (CRYSTAL 240)



TASTING NOTES
 TREACLE TOFFEE,
 DARK CARAMEL

BEER STYLES	USAGE RATE	RECIPE
Best bitters, milds, porters, (not stouts)	Up to 10%	Crisp Strong Mild See page 115

With Medium Crystal those intense caramel flavours of thick treacle toffee are developed. To achieve these kinds of flavours the temperature is raised a further step from Light Crystal and the sugars darken further still giving the beer a deep copper hue.

Remember that Crystal Malts have no enzymes or FAN preserved so be careful with the addition rate in your mash. You want to add enough to get the depth of flavour desired, but not so much that you will have issues in fermentation due to a lack of nutrients.

TYPICAL ANALYSIS

PARAMETER	IoB	EBC	ASBC
MOISTURE	3.5% max	3.5% max	3.5% max
EXTRACT	270 L°/kg	71.0%	71.0%
COLOUR	225-265 EBC	245-290 EBC	93-110 °L

DARK CRYSTAL (CRYSTAL 400)



TASTING NOTES
 DRIED FRUITS

BEER STYLES	USAGE RATE	RECIPE
Ruby, porters	Up to 10%	Crisp Ruby See page 116

Dark Crystal Malt has the highest degree of caramelisation. The flavours are now transformed into sultanas, raisins, plums and dark, dried fruits. By now the sugars are actually being broken down by chemical processes and so the residual sweetness that the other Crystal Malts impart are being replaced by an increase in bitter flavours.

Crystal Malt sugars are non-fermentable so add a level of dextrin sugars that are preserved through to the final beer.

TYPICAL ANALYSIS

PARAMETER	IoB	EBC	ASBC
MOISTURE	3.0% max	3.0% max	3.0% max
EXTRACT	270 L°/kg	71.0%	71.0%
COLOUR	380-435 EBC	420-480 EBC	159-182 °L

CRYSTAL RYE MALT



TASTING NOTES

SWEET, SPICY, WARMING
CHARACTER

BEER STYLES

*Rye IPAs, rye pale ales,
red ale, roggenbier*

USAGE RATE

Up to 10%

By passing still moist malted rye through the crystallisation process, we can accentuate the spicy flavours that are characteristic of the grain. Not only is the flavour enhanced, but the sugars present take on a red hue, a much sought after attribute in red ales.

Try it in a variety of styles including traditional Irish reds, German roggenbier or in modern hop forward IPA and DIPAs.

TYPICAL ANALYSIS

PARAMETER	IoB	EBC	ASBC
MOISTURE	5.0% max	5.0% max	5.0% max
EXTRACT	270 L°/kg	71.0%	71.0%
COLOUR	200-400 EBC	220-440 EBC	83.5-166.5 °L

CARA GOLD MALT



TASTING NOTES

FRUITY

BEER STYLES

*All beer styles
(foam and mouthfeel)*

USAGE RATE

Up to 15%

RECIPE

*Crisp Golden Ale
See page 105*

Cara Gold is the lowest colour of the crystallised malts. Cara Gold yields fruity and toffee flavour notes that are carried through to the beer.

This low malt colour produces a golden orange lager with increased body and fullness, and a softer, rounder mouthfeel with improved drinkability.

TYPICAL ANALYSIS

PARAMETER	IoB	EBC	ASBC
MOISTURE	6.5% max	6.5% max	6.5% max
EXTRACT	280 L°/kg	74.0%	74.0%
COLOUR	12-16 EBC	13.0-18.0 EBC	5.4-17.2 °L

CARA MALT



TASTING NOTES
 SWEET CARAMEL, MALTY

BEER STYLES

All beer styles
 (foam and mouthfeel)

USAGE RATE

Up to 15%

RECIPE

Crisp Session Bitter
 See page 110

Cara Malt is a very low colour Crystal Malt which has an almost completely glassy endosperm. It contains a greater degree of sweetness than Crystal Malt and the harsher nutty roasted flavours are not present.

It greatly improves body, foam retention and beer stability whilst adding little colour. It has therefore, become very popular in the production of lagers where it is used to assist in enhancing flavour and character. For this reason it has also become a common constituent in low alcohol beers.

TYPICAL ANALYSIS

PARAMETER	IoB	EBC	ASBC
MOISTURE	6.0% max	6.0% max	6.0% max
EXTRACT	277 L°/kg	73.0%	73.0%
COLOUR	23-32 EBC	25.0-35.0 EBC	9.9-13.7 °L





SPECIALITY MALTS

If you're looking for something different, try some of our specialist malt. Using rye, wheat or oats can help to enhance the body and improve head retention, whilst creating deep flavours and spice to the beer.

By malting these grains using a variety of techniques, including our RevTech Speciality Malt Plant, our maltsters are able to elevate these humble grains into malts that are bursting with flavour and mouthfeel.

As new beer styles emerge it is often the malts that shine bright; from the creamy body of a NEIPA created by adding our Naked Oat Malt, to the deep red tone and spice notes in a Rye IPA from our high colour Rye Malt, our speciality malts are here to add that something extra.

LIGHT MUNICH MALT



TASTING NOTES
RICH MALTY & BREAD
CRUST FLAVOURS

BEER STYLES

Marzen, maibock

USAGE RATE

Up to 100%

RECIPE

*Crisp German Maibock
See page 102*

Our Light Munich Malt is created by taking Vienna Malt a stage further in the kiln. The additional heat promotes melanoidin reactions to produce rich bread crust flavours. Again, Light Munich Malt can be used as a base since the enzymes are suitably preserved in this malt.

The use of Munich and Vienna Malts are not just for German style beers, they add a beautiful subtle complexity to many beer styles.

TYPICAL ANALYSIS

PARAMETER	IoB	EBC	ASBC
MOISTURE	4.5% max	4.5% max	4.5% max
EXTRACT	299 L°/kg	79.0%	79.0%
COLOUR	15-25 EBC	16.5-27.5 EBC	6.7-10.8 °L
TN/TP	1.60-1.80%	10.0-11.3%	10.0-11.3%

DARK MUNICH MALT



TASTING NOTES
RICH MALT, BREAD
CRUST, GRAINY

BEER STYLES

*Dunkel, bock,
doppelbock*

USAGE RATE

*We recommend
15-20%**

A magical thing happens when amino acids and reducing sugars combine at critical temperatures; the Maillard reaction. Starting with higher protein spring barley we germinate to higher levels of modification then adjust early kilning conditions to utilise the malt enzymes to hydrolyse protein and convert starch in sugars.

Finally, a long drying phase with a higher temperature results in the Maillard reaction taking place to produce pronounced rich malt, freshly baked bread crust and the characteristic Munich bite at the back of the palate.

**Up to 100% (lower DP and extract than light Munich so at 100% less speciality malt can be added).*

TYPICAL ANALYSIS

PARAMETER	IoB	EBC	ASBC
MOISTURE	4.5% max	4.5% max	4.5% max
EXTRACT	299 L°/kg	79.0%	79.0%
COLOUR	35-45 EBC	38-50 EBC	14.8-19.3 °L
TN/TP	1.60-1.80%	10.0-11.3%	10.0-11.3%

DEXTRIN MALT

Alternative malt for CaraPils, CaraFoam, Torrefied Wheat



TASTING NOTES
NEUTRAL (UP TO 10%)

BEER STYLES

Added as a foam and body enhancer

USAGE RATE

5-15%

RECIPE

Crisp Table Beer
See page 100

Dextrin Malt is produced by constraining the germination phase, which results in retention of higher molecular weight polysaccharides which will provide positive attributes to the finished beer in terms of greater body and mouthfeel. These dextrans will contribute positively to head formation.

This malt can be particularly beneficial when brewing with well modified Extra Pale Malt to produce golden ales or pilsner-style beers. The low colour permits usage rates of up to 15% without impacting on final product colour. It can be useful in a low gravity beer such as a session IPA that is trying to emulate a higher gravity beer in terms of body.

TYPICAL ANALYSIS

PARAMETER	IoB	EBC	ASBC
MOISTURE	7.0% max	7.0% max	7.0% max
EXTRACT	300 L ^o /kg	80.0%	80.0%
COLOUR	2.0-3.0 EBC	2.2-3.3 EBC	1.3-1.7 °L
TN/TP	1.40-2.00%	8.8-12.5%	8.8-12.5%
SNR/KI/ST RATIO	26-35	30-40	30-40

WHEAT MALT



TASTING NOTES
TOUCH OF ACIDITY, GENTLE,
REFRESHING & CREAMY

BEER STYLES

Hefeweizen, wheat beers, wit

USAGE RATE

Up to 50% - huskless so watch run off

RECIPE

Crisp Irish Stout
See page 119

In brewing, Wheat Malt can be used as the base malt at around 55% inclusion for wheat beers.

When mixed with barley malt, Wheat Malt can improve head retention, improve mouthfeel and introduce flavour changes in other beer types.

TYPICAL ANALYSIS

PARAMETER	IoB	EBC	ASBC
MOISTURE	6.5% max	6.5% max	6.5% max
EXTRACT	320 L ^o /kg	84.0%	84.0%
COLOUR	2.5-5.0 EBC	2.8-5.5 EBC	1.5-2.5 °L
TN/TP	2.20%	12.5%	12.5%
SNR/KI/ST RATIO	38-46	43-52	43-52
DP/DPWK/LINTNER	130 min IoB	400 min WK	143 min °L

RYE MALT



TASTING NOTES

EARTHY, SPICY
AFTER-TASTE

BEER STYLES

Rye IPAs, rye pale ales,
red ale, roggenbier

USAGE RATE

Up to 15%*

RECIPE

Crisp London Porter
See page 118

In brewing, when mixed with barley malt, Rye Malt can improve head retention, improve mouthfeel and introduce flavour changes of a toffee/caramel note at lower inclusion rates and a spicy after-palate at higher inclusion rates.

Most notably, Rye Malt will also impart a reddish hue to beers.

**Rye Malt is higher in beta glucans which can cause issues at higher rates. Recommend rice hulls.*

TYPICAL ANALYSIS

PARAMETER	IoB	EBC	ASBC
MOISTURE	6.0% max	6.0% max	6.0% max
EXTRACT	328 L°/kg	86.5%	86.5%
COLOUR	12.0-32.0 EBC	13-35 EBC	5.4-13.7 °L
TN/TP	1.60%	10.0%	10.0%
SNR/KI/ST RATIO	37-46	42-52	42-52
DP/DPWK/LINTNER	45 min IoB	180 min WK	62 min °L

NAKED OAT MALT



TASTING NOTES

CREAMY, OATY

BEER STYLES

NEIPAs, oatmeal
stout, oaty pale ales

USAGE RATE

Up to 30%

SEE RECIPE

Crisp Oaty Pale Ale
See page 104

Crisp Naked Oat Malt has become a stalwart of the NEIPA recipe. We malt naturally naked oats to increase potential extract. Naked Oat Malt gives a lovely creaminess and mouthfeel in all styles of beer and is especially suited to juicy hop bombs and heavy beers. They also impart a toasted, biscuit aroma and palate.

Oats are high in β -glucan and for both brewing and baking uses Naked Oat Malt can contribute beta-glucans (soluble fibre) to add an extra property.

If run-off is a concern at higher addition rates, mix 50/50% with our Flaked Torrefied Oats.

TYPICAL ANALYSIS

PARAMETER	IoB	EBC	ASBC
MOISTURE	5.5% max	5.5% max	5.5% max
EXTRACT	245 L°/kg	65.0%	65.0%
COLOUR	2.0-7.0 EBC	2.2-7.8 EBC	1.3-3.4 °L
TN/TP	2.70%	17.0%	17.0%
SNR/KI/ST RATIO	11-14	14-17	14-17
DP/DPWK/LINTNER	500-1200 min IoB	730-1750 min WK	730-1750 min °L

19

No.19
FLOOR
MALT®

Crisp has a long and proud tradition of producing the highest quality floor malt which continues to this day with malt still being produced in our No 19 floor malting at Great Ryburgh.

We produce small batch, handcrafted malt using techniques which date back to when the malting floors were built in the 1870s.

Our floor malting is one of the last still operating within the UK and the malt it produces is highly prized by brewers worldwide.



FLOOR



Floor malted Maris Otter® remains the quintessential ale brewing malt.

Although traditional in nature, the malt produced in No 19 is subject to the same stringent process and quality control procedures as the malt produced in our modern malting plants.

A full range of bespoke ale, lager and distilling floor malts plus other malted cereals can be made to order.



MARIS OTTER®

TASTING NOTES

LONGER, GENTLE GERMINATION &
 KILNING IMPARTS UNIQUE & HIGHLY
 VALUED FLAVOURS & AROMAS



COLOUR (IoB)
 5.0 – 7.0

BEER STYLES	USAGE RATE	RECIPE
Best bitter, porters, barley wines	80 – 100%	Crisp Barley Wine See page 122

The N° 19 floor at our Great Ryburgh maltings dates back to when Crisp began and has been producing malt virtually uninterrupted since the late 19th century.

We take our superior Maris Otter® barley and malt it in the traditional way; hand turned, germinated slowly on the floors and kilned for over three days to maximise the robust flavours associated with Maris Otter® Ale Malt. The result is a rich malt of superior quality; a true celebration of heritage and malting knowhow.

TYPICAL ANALYSIS

This is a bespoke product therefore no typical analysis is available.

ORGANIC MALTS

ORGANIC ALE MALT | ORGANIC EXTRA PALE MALT
 ORGANIC CRYSTAL MALT

TASTING NOTES

FLAVOURS ARE THE SAME AS THEIR
 NON-ORGANIC COUNTERPARTS



Crisp's Organic Malt fully complies with the strict regulations which govern the qualification of foods as 'organic'. These rules and systems, having their basis in EU law, apply not only to the handling and processing of the organic barley at the malting plant, but also through the supply chain from the condition of the land sown and the provenance of the seed through to cultivation and harvesting.

TYPICAL ANALYSIS

ORGANIC ALE MALT

PARAMETER	IoB	EBC	ASBC
MOISTURE	4.0% max	4.0% max	4.0% max
EXTRACT	308 L°/kg	81.5%	81.5%
COLOUR	4.5-7.0 EBC	5.0-7.5 EBC	2.3-3.3 °L
TN/TP	1.70%	10.6%	10.6%
SNR/KI/ST RATIO	37-44	42-50	42-50

ORGANIC EXTRA PALE MALT

PARAMETER	IoB	EBC	ASBC
MOISTURE	4.5% max	4.5% max	4.5% max
EXTRACT	308 L°/kg	81.5%	81.5%
COLOUR	2.5-4.0 EBC	2.8-4.5 EBC	1.5-2.2 °L
TN/TP	1.70%	10.6%	10.6%
SNR/KI/ST RATIO	37-44	42-50	42-50

ORGANIC CRYSTAL MALT

PARAMETER	IoB	EBC	ASBC
MOISTURE	5.0% max	5.0% max	5.0% max
EXTRACT	270 L°/kg	72.0%	72.0%
COLOUR	150-170 EBC	165-190 EBC	165-190 °L



NON-MALTED CEREALS

Our selection of non-malted cereals are made using torrefying and micronising techniques to gelatinise the starchy endosperm which means the cereal doesn't need to be pre-cooked before it is used in your mash tun. In addition, all of the flaked products don't need to be milled either.

Some non-malted cereals can add protein for head retention, body and mouthfeel and others will lighten the colour and allow for super pale, crisp beers to be developed.

They can also be used in distilling in the mash tun as a sugar substrate for the production of innovative craft spirits.

TORREFIED WHEAT



TASTING NOTES
SLIGHT GRAIN

BEER STYLES

All styles. Main benefit is improved head retention

USAGE RATE

10% max

SHELF LIFE

6 months in dry and pest free conditions

Torrefied Wheat has long been used by brewers up and down the UK to provide additional head potential on all beer styles. The higher molecular weight proteins and glycoproteins are head positive and also promote mouthfeel. It is especially useful when base malts are particularly low in nitrogen/ protein.

Torrefied Wheat has a very slightly grain character to it.

TYPICAL ANALYSIS

PARAMETER	IoB	EBC	ASBC
MOISTURE	10.0% max	10.0% max	10% max
EXTRACT	310 L°/kg	82.0%	82.0%

FLAKED TORREFIED BARLEY



TASTING NOTES
SLIGHTLY MORE HARSH
FLAVOUR/BITE THAN
TORREFIED WHEAT

BEER STYLES

All styles. Main benefit is improved head retention. Suited to stouts for bite.

USAGE RATE

10% max

SHELF LIFE

6 months in dry and pest free conditions

Flaked Torrefied Barley consists of barley grains that have been cooked at high temperature, resulting in gelatinisation of the starchy endosperm. Adding it promotes head retention and adds body to the finished beer. Its flavour is slightly stronger than its wheat counterpart. It does not require milling before being added to the mash, and retains its husk so can be used as an alternative to wheat in beers where the recipe already has a lot of huskless grains.

TYPICAL ANALYSIS

PARAMETER	IoB	EBC	ASBC
MOISTURE	10.0% max	10.0% max	10.0% min
EXTRACT	308 L°/kg	81.0%	81.0%

FLAKED TORREFIED MAIZE



TASTING NOTES
CORN FLAKES, CORN

BEER STYLES

Continental lagers,
prohibition lager

USAGE RATE

Up to 25%

SHELF LIFE

6 months in dry and
pest free conditions

RECIPE

Crisp Pre-Prohibition Lager see page 98

Flaked Torrefied Maize consists of maize grits that have been micronized at high temperatures which bursts open the starches and thus gelatinises the maize. It lightens wort and can add a unique corn flake-like sweetness to beers.

Maize can also be used by distillers to create bourbon style whisky without needing to pre-cook the maize. Crisp's Flaked Torrefied Maize is GM-free.

TYPICAL ANALYSIS

PARAMETER	IoB	EBC	ASBC
MOISTURE	8.5% max	8.5% max	8.5% max
EXTRACT	328 L°/kg	86.5%	86.5%

FLAKED TORREFIED RICE



TASTING NOTES
DRYNESS & CRISP FINISH

BEER STYLES

Light lagers

USAGE RATE

Up to 25%

SHELF LIFE

6 months in dry and
pest free conditions

RECIPE

Crisp Low Gluten Pale Ale see page 103

Flaked Torrefied Rice consists of rice grains that have been cooked at high temperature, resulting in gelatinisation of the starchy endosperm, and then flaked. It lightens wort colour, reduces protein levels and imparts a characteristic dryness to finished beers.

Rice has low gluten so can be used for crafting low gluten products.

TYPICAL ANALYSIS

PARAMETER	IoB	EBC	ASBC
MOISTURE	8.5% max	8.5% max	8.5% max
EXTRACT	305 L°/kg	80.5%	80.5%

FLAKED TORREFIED OATS



TASTING NOTES
 SMOOTH, CREAMY
 MOUTHFEEL

BEER STYLES	USAGE RATE	SHELF LIFE
Stouts, NEIPAs	Up to 25%	6 months in dry and pest free conditions
RECIPE		
<i>Crisp Oatmeal Stout see page 120</i>		

Flaked Torrefied Oats consist of husked oat grains that have been cooked at high temperature, resulting in gelatinisation of the starchy endosperm, and then flaked. They will give a smooth, creamy mouthfeel to finished beers.

The presence of oat husk can assist with wort separation, especially if the grist contains naked grains such as Malted Rye, Naked Oat Malt or Wheat Malt.

TYPICAL ANALYSIS

PARAMETER	IoB	EBC	ASBC
MOISTURE	11.0% max	11.0% max	11.0% max
EXTRACT	292 L ^o /kg	77.0%	77.0%



NON-MALTED



DISTILLING MALT

Crisp have been making distilling malt in Scotland for over 40 years. We now have two maltings, one in the traditional brewing town of Alloa and the other in the heart of Speyside at Portgordon. Between them, they cater for the malt requirements of Scotch Whisky production; plain, peated and high diastatic.

Over the years we've forged long lasting partnerships with farmers in Morayshire, Aberdeenshire and Fife, to grow low nitrogen (protein) distilling varieties which allows us to produce flavourful distilling malts that are prized not just in Scotland but also in Japan, the USA and Europe.

Our peating process on Speyside ensures the fullest absorption of 'reek' by the grain during the peat burn. Whereas with some dry smoked peated malts the flavour and aroma quickly fades over a short time, our method produces a lasting rich peat smoke character in the malt and so it can be transported all over the world without issue.

To cater to small and large distillers alike, our plain pot still and peated malts are available in bulk, one tonne or 25kg bags.

PREMIUM POT STILL MALT



TASTING NOTES
 NEUTRAL MALT FLAVOUR

PSY

410 Litres of alcohol – per tonne

Made from spring distilling approved varieties, our Premium Pot Still Malt is GN free to avoid any ethyl carbamate issues in the still. Flavourful and high alcohol yielding, this malt is the workhorse of many a Scottish distillery. The north east of Scotland produces especially low nitrogen barley which translates into excellent spirit yield in the distillery.

With enough diastatic power to convert itself and other malts, you can combine it with our speciality malts to create complex and layered whiskies.

TYPICAL ANALYSIS

PARAMETER	IoB	EBC	ASBC
MOISTURE	4.3%		
SOLUBLE EXTRACT AS IS	78.6%	80%	80%
FERMENTABILITY	87.2%	n/a	n/a
PSY	410 laa/t	n/a	n/a
TN (MALT)	1.45%	9.0%	9.0%
SNR	38.0	43.0	43.0
FRIABILITY	93%		

PEATED POT STILL MALT



TASTING NOTES
 PEAT SMOKE, PHENOLIC

PSY

410 Litres of alcohol – per tonne

Utilising peat from Aberdeenshire and the same spring barley as our Premium Pot Still Malt, we slowly peat our malt to give fullest absorption of phenols by each grain. This results in a depth of flavour that will not fade in storage and will provide that hallmark peat character in your whisky.

Our heavy peated malt is measured at upwards of 50 ppm of total phenol.

TYPICAL ANALYSIS

PARAMETER	IoB	EBC	ASBC
MOISTURE	4.3%		
SOLUBLE EXTRACT AS IS	78.6%	80%	80%
FERMENTABILITY	87.2%	n/a	n/a
PSY	410 laa/t	n/a	n/a
TN (MALT)	1.45%	9.0%	9.0%
SNR	38.0	43.0	43.0
FRIABILITY	93%		

HIGH DIASTATIC POWER (HDP) MALT



TASTING NOTES
 NEUTRAL FLAVOUR

DIASTATIC POWER

160°IoB (dry)/600°WK/176°Lintner

From barley grown in central Scotland and malted at our Alloa maltings, our HDP Malt is used to produce grain whisky as well as other spirits where the majority of the grain bill lacks enzymes for conversion. At just 10% addition, this malt will convert any starch-rich cereal such as wheat, rice or maize.

This can be used at normal malt mashing temperatures with our flaked products to produce American-style whiskies. HDP Malt is known as Distillers Malt in the USA.

TYPICAL ANALYSIS

PARAMETER	IoB	EBC	ASBC
MOISTURE	6.5%		
DU	60		
DP	160°IoB (dry)	600°WK	176°Lintner

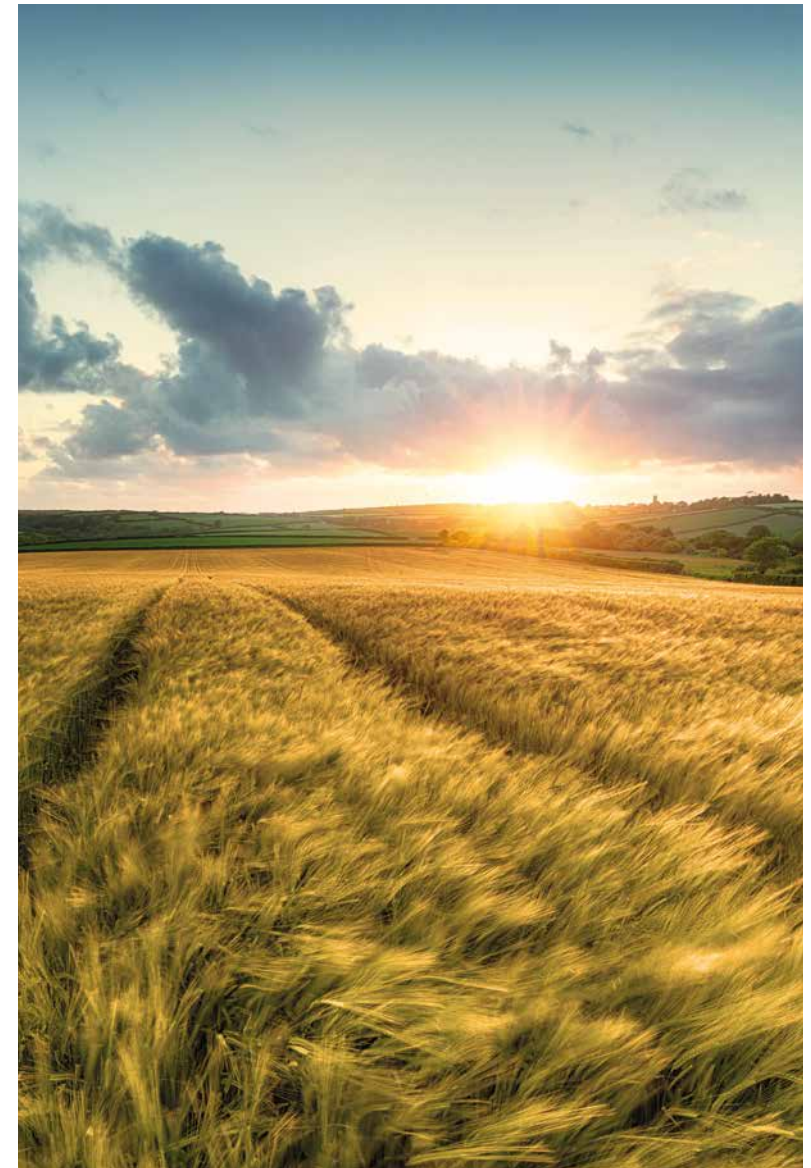

OUR DISTRIBUTION NETWORK



Get in Touch

Please email us on export@crispmalt.com, with your name, location, annual quantities and contact information and we will introduce you to your local distributor

We've partnered with knowledgeable, approachable and trusted distributors around the world.



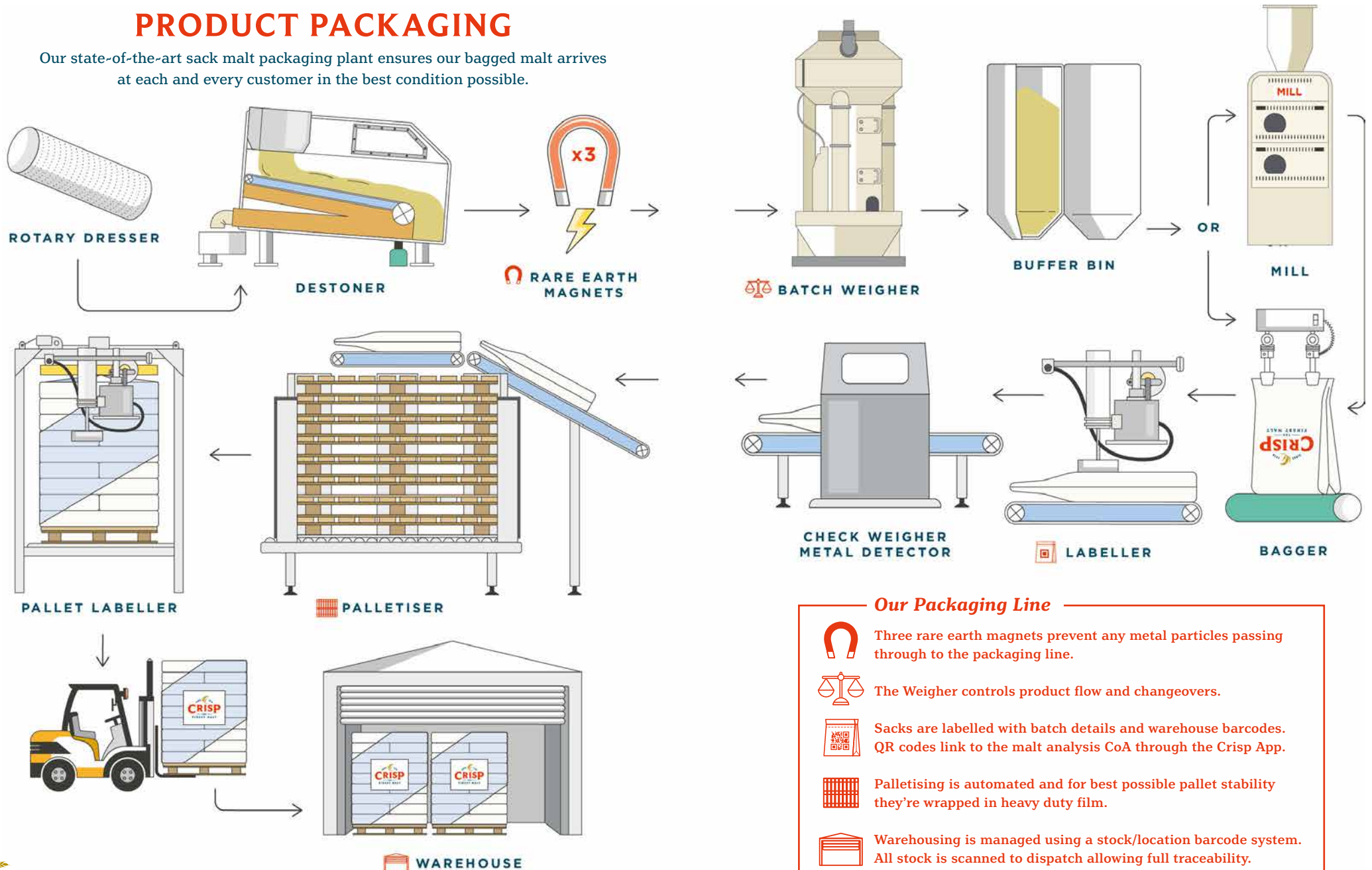

In regions where we can't physically be there, our distributors are hand-picked to ensure the high levels of customer service, product quality and technical support offered to our local brewers and distillers is continued to fellow brewers and distillers overseas.

PRODUCT PACKAGING

Our state-of-the-art sack malt packaging plant ensures our bagged malt arrives at each and every customer in the best condition possible.



Our Packaging Line

-  Three rare earth magnets prevent any metal particles passing through to the packaging line.
-  The Weigher controls product flow and changeovers.
-  Sacks are labelled with batch details and warehouse barcodes. QR codes link to the malt analysis CoA through the Crisp App.
-  Palletising is automated and for best possible pallet stability they're wrapped in heavy duty film.
-  Warehousing is managed using a stock/location barcode system. All stock is scanned to dispatch allowing full traceability.

BEER BUILDING BLOCKS



BEST BITTER

- 0.5% ROAST BARLEY SPECIAL MALT
- 3.5% CARA SPECIAL MALT
- 4% AMBER SPECIAL MALT
- 7% CRYSTAL 150 SPECIAL MALT



Recipe page 111



ENGLISH ESB

- 0.5% ROAST BARLEY SPECIAL MALT
- 3% AMBER SPECIAL MALT
- 4.5% CRYSTAL 150 SPECIAL MALT



Recipe page 112



BROWN ALE

- 4% WHEAT SPECIAL MALT
- 2% CHOCOLATE SPECIAL MALT
- 6% BROWN SPECIAL MALT
- 3% CRYSTAL 150 SPECIAL MALT



Recipe page 117



PORTER

- 4% RYE SPECIAL MALT
- 4% CHOCOLATE SPECIAL MALT
- 4% BROWN SPECIAL MALT
- 3% CRYSTAL 400 SPECIAL MALT



Recipe page 118



OATMEAL STOUT

- 10% FLAKED T OATS SPECIAL MALT
- 2% BROWN SPECIAL MALT
- 2% CRYSTAL 400 SPECIAL MALT
- 6% BLACK SPECIAL MALT



Recipe page 120



GET IN TOUCH

We love nothing more than visiting breweries and distilleries, talking to you about your process and getting hands on to help you get the very best out of Crisp malt.

We know this can only happen when we build strong relationships with our customers, we'd love to hear from you, understand your malt needs and show how our malts can make all the difference to your beers and spirits.

CHEERS!



Crisp Malt

Great Ryburgh, Fakenham
Norfolk NR21 7AS, England

+44 (0)1328 829 391
sales@crispmalt.com

 @CrispMalt  @crispmaltings

CRISPMALT.COM