

CUSTOMER APPROVAL

Cust Name	
Cust Signature	
Approval Date	

Customer Capacity	750mL
Fill Point Volume	753mL ± 5.5mL Nom @ 30mm
Brimful Volume	762mL Nom
Weight	530g
Available Colours	FL FG AG AB
Tilt Angle	16.9°
Process	BB

The WPA recommend that the label should be positioned at a minimum of 5mm above the bottom of the designated label panel and a minimum of 5mm below the top of the designated label panel with a maximum label height that is equal to or less 10mm than is shown as the designated label panel height on the glass drawing

Customer Specifications - Orora Glass



Number	AG045_R01	C	Gas Rating Removed	13 05 2014
Description	750mL BVS CR Premium Claret	B		14 10 2013
Date & Revision	13 05 2014 Revision C	A	Internal pressure rating was 2 G.V Max	04 05 2011
Finish	R01 CMP - 30x60 BVS	Initial	Was SD19 08	
		Rev	Description	Date

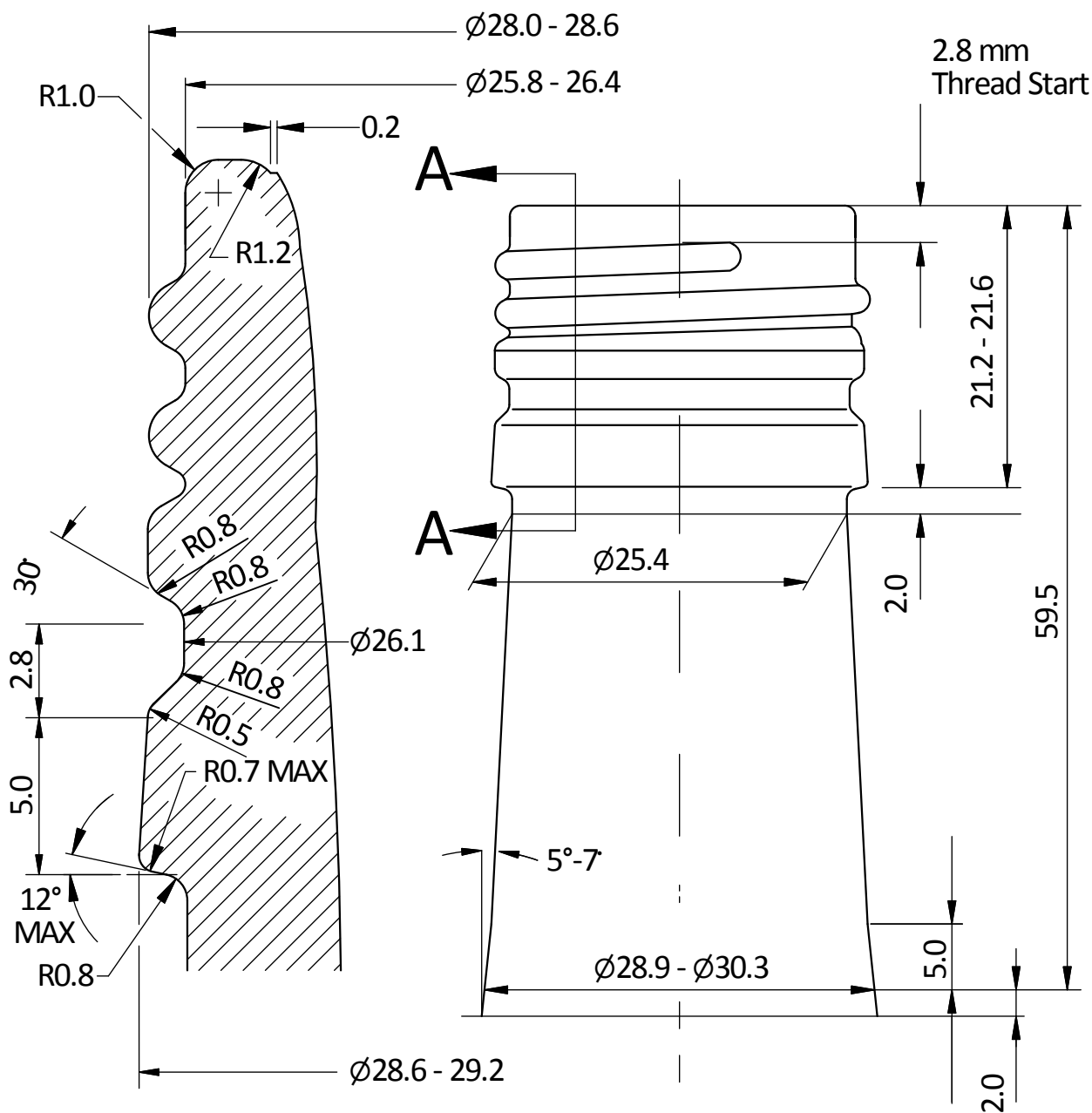

SECTION A-A

THREAD DETAIL

PITCH 3.63

Minimum through bore diameter is 17.50mm

Customer Specifications - Orora Glass



Finish Number R01 CMP

Description 30 x 60 BVS Finish with take-out groove - Closed Mould Pick-up

Date & Revision 02/09/2013 Rev B