



www.mud-busters.com

Email us for digital instructions: Mudbusters@gracemfg.com

Thank you for purchasing MudBuster's **BRP Super Extended Fenders for the Can-Am X3** ! We manufacture the best-selling fender flare kits for UTVs and side by sides! All MudBusters products are made in the USA, and these fender flares are manufactured from high-quality American made material. Your new extended fenders are designed to deflect debris and reduce the amount of mud that typically gets thrown from the tires into unwanted areas. They can withstand a lot of abuse, but they are not designed for crash protection, absorbing impacts, rollovers, or uprooting trees. If you have an accident or if you happen to damage your fenders, order discounted replacement fenders by phone (for existing customers only). Unlike other manufacturers, you do not have to buy a complete set if you damage just one fender.

IMPORTANT:

Some of the images in the instructions below may differ from the actual product. In our continual effort to increase customer satisfaction, we may change the style, material, and/or hardware to serve you better. If your fenders get slightly distorted while in transit, apply pressure to the distorted areas to straighten them out before installation.

Use caution when drilling into the factory panels of your vehicle. Make sure that you do not penetrate the surrounding parts or the chassis (unless instructed). Self-tapping screws and push rivets are included as an effective and easy way to fasten the fender flares to your machine. However, you can use other methods of securing our extended fenders to your vehicle as well (i.e., rivets, misc. hardware, etc.). Remember, it may be helpful to have a friend assist you with the installation.

Unboxing:

Carefully open your package from the box's top (or bottom) by removing the staples with a flat-head screwdriver or pliers. Slide the fenders out of the box and make sure that any staples do not scratch your fenders. MudBusters are formed to fit your machine but shipped in a narrow box. You may find it necessary to apply pressure and re-bend some of your fenders for a better fit. Don't worry, they're very durable and will not break from re-shaping them!

Note: Using a larger drill bit may allow the fender to come off when riding! The rivets need to be a tight fit to secure the fender flare to the fender. We recommend a 21/64" drill bit.

Note: Max coverage set shown. Smaller sets (Mud-Lite, or Race-Lite) may have less hardware in the front of the front fender or the lower front of the rear fender than pictured. In these cases, it may be helpful to use the rear mounting locations first for installation ease.

Thank you for your business!

Please send us pictures and/or videos of your vehicle with MudBusters installed to our Facebook page

<https://www.facebook.com/UTVMudbusters/>

#utvmudbusters.com

or email us via mudbusters@gracemfg.com

We may feature your ride on our website, social media, Amazon and/or eBay!

For technical assistance or product inquiries, please call us at:

1-844-MUD-FLAPS or 844-683-3527

Hours: Mon-Fri 8-4 MST

▲ WARNING

This product can expose you to chemicals, including phthalates which are known to the State of California to cause cancer or birth defects or other reproductive harm. For more info, go to www.p65Warnings.ca.gov

Installation Instructions

Can-Am X3 BRP Super Extended Fenders

Short Front Fender Installation

- 1) Remove the fender extensions from the box and re-bend the fenders until they fit tight against the factory fender (see **Figure 1**).
- 2) Using a 5/16 drill bit and a cordless drill, press the fender extension tight against the fender and drill the first hole as specified in **Figure 2**. Insert a plastic rivet after each hole is drilled. **NOTE:** All holes can be plugged with an 8mm plastic rivet if you decide to remove your MudBusters.

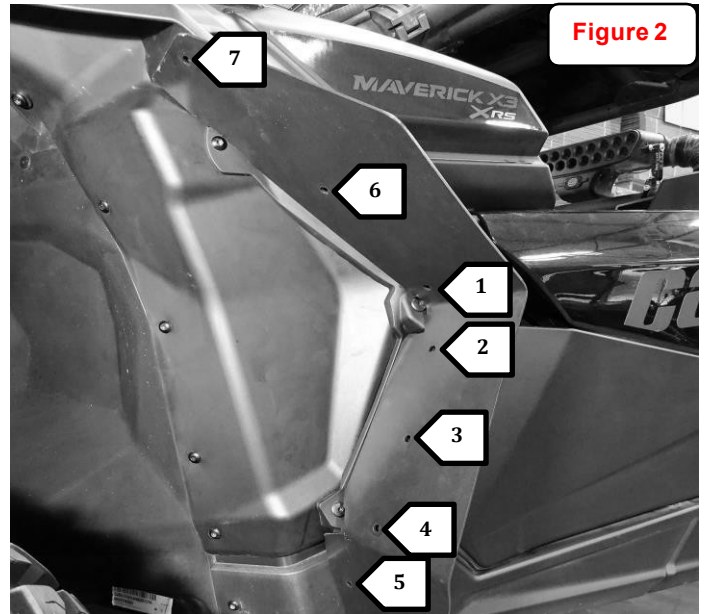
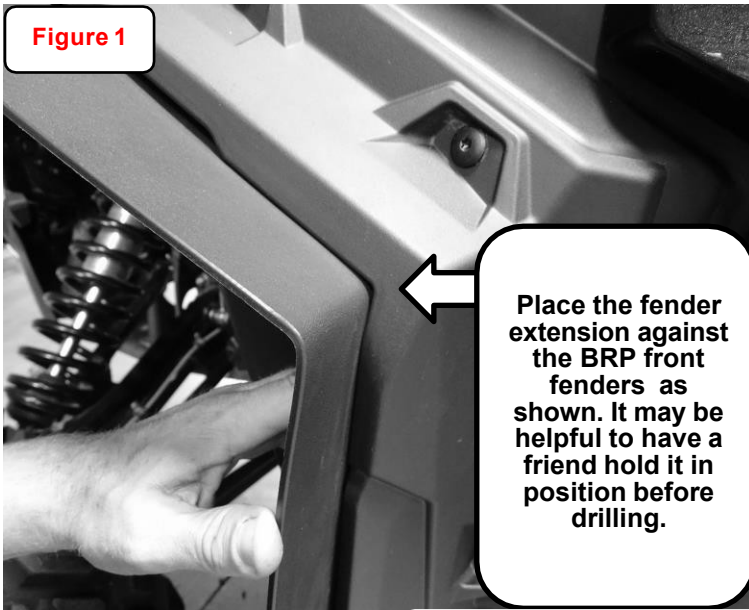

Installation Instructions

Can-Am X3 BRP Super Extended Fenders

Large Front Fender Installation



1. Follow the previous instructions from **Figure 1** & **Figure 2**.
2. Remove the factory bolt shown in **Figure 3**, align the hole in the fender, and re-install it.
3. Add (1) plastic rivet as shown in **Figure 3**.
4. Install the tip of the fender as shown in **Figure 4** using the supplied M6 bolt with a washer on the backside. You will be re-using the M6 nut from the factory bolt.

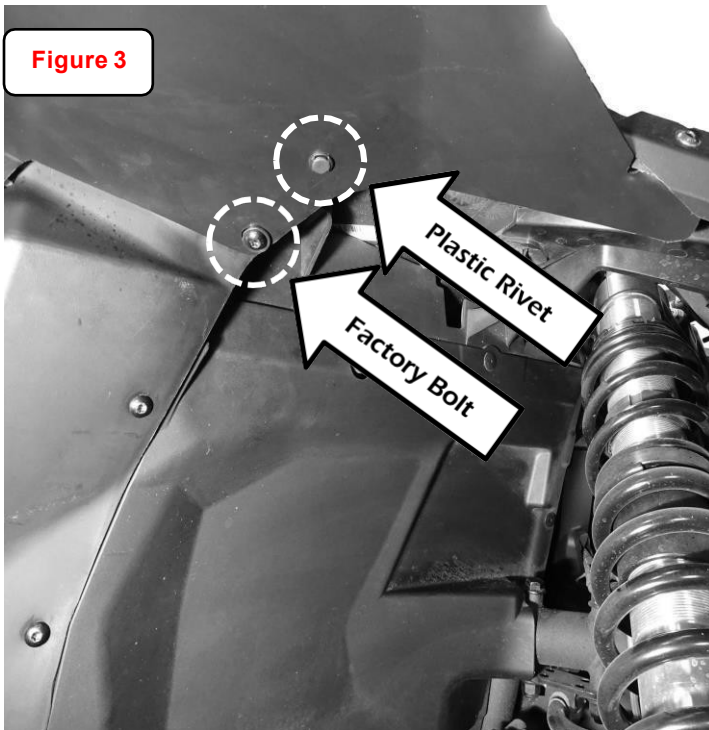

Installation Instructions

Can-Am X3 BRP Super Extended Fenders

Rear Fender Installation

1. Locate the factory bolt under the rear factory fenders circled below (bolt #1) in **Figure 4**. Remove and set aside.
2. Place the fender inside the wheel well and re-install bolt #1 (finger tight) with (1) large washer. This will help keep the fender in position while you install the remaining hardware. Mount the fender as seen in **Figure 5**. Install (3) 1" bolts (with washers on both sides) and lock-nuts on the backside of the factory fender. With the hardware loose, position the fender to your desired amount of coverage before continuing to step 3.

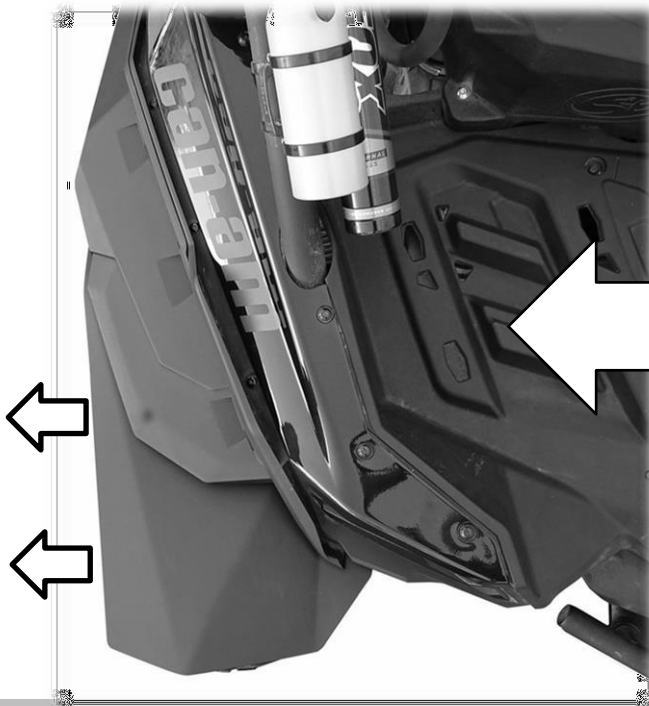
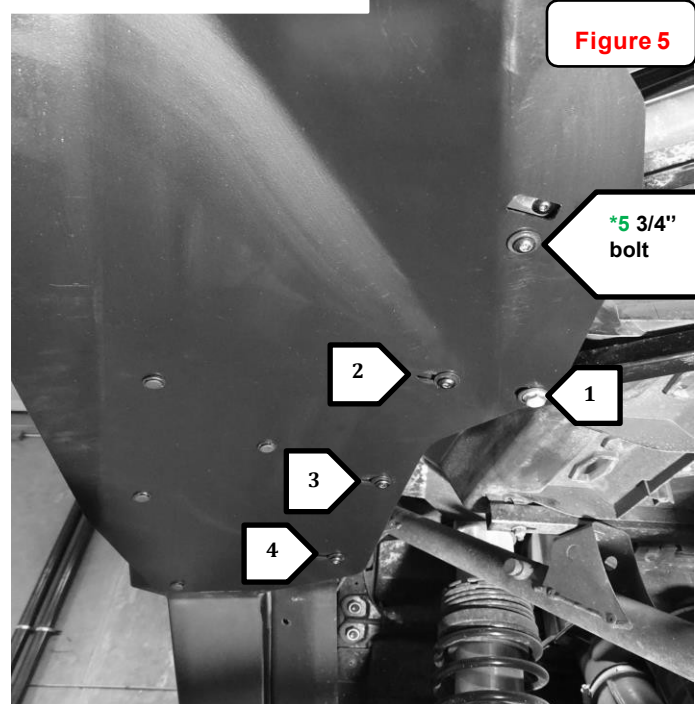
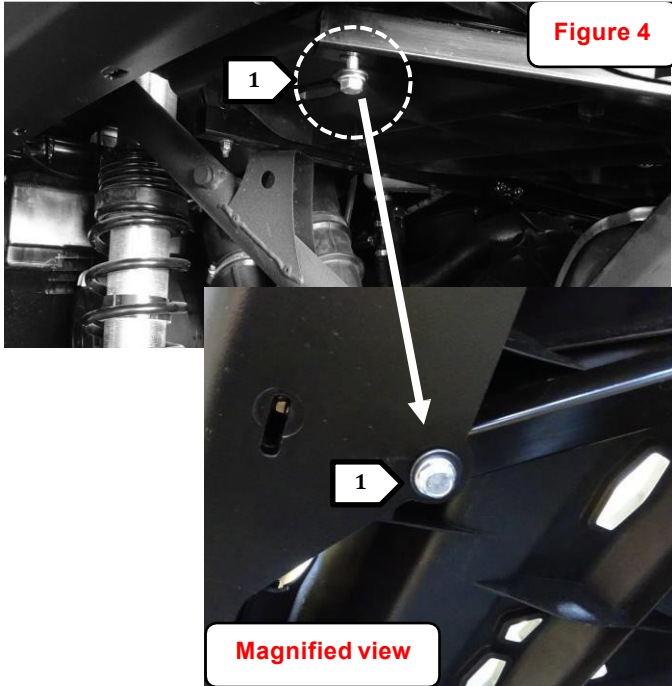

Adjust the rear fenders to suit your needs before installing the plastic rivets and bolt #5*. We recommend extending the rear fenders outward for X3 RS models and DS/Base models with aftermarket wheels.

Installation Instructions

Can-Am X3 BRP Super Extended Fenders

Rear Fender Installation



- 3) Drill a 1/4" hole for bolt #2 as seen in [Figure 6](#). Insert (1) 3/4" bolt with a washer on both sides and a lock-nut on the back side. You will notice the fender is cut to fit around the bolt just behind the hole you just drilled. This is not a secure mounting point. Thus, it is necessary to install bolt #2.
- 4) At this point, the upper rear fenders should be mounted. Proceed to the outer section of the rear fenders. Hold the fenders up against the BRP Extended Fender and drill 4 holes with a 5/16 drill bit necessary to mount the fender. Insert 4 plastic rivets into the holes and tighten down all of the hardware to complete the installation. (see [Figure 7](#))

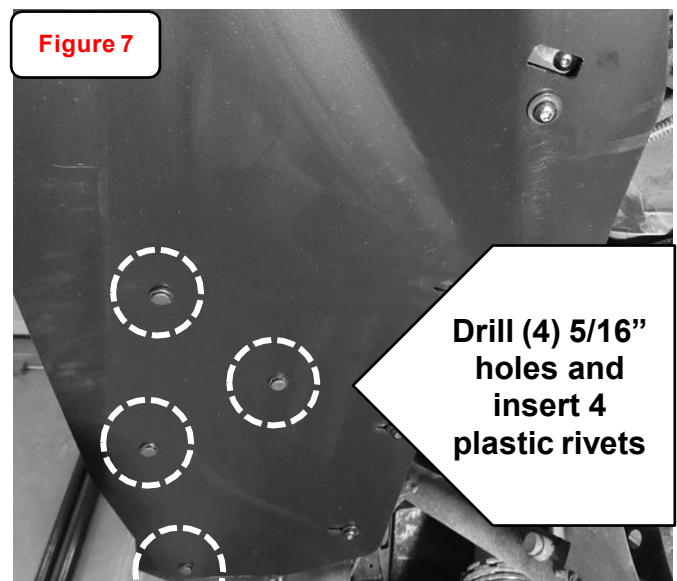
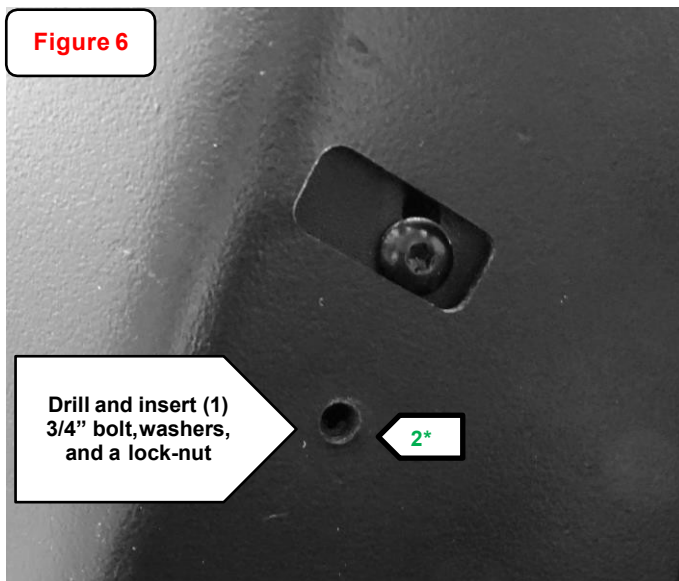

Hardware Included

Short Front Fender Flares

- (2) Front fenders
- (14) Plastic Rivets

Large Front Fenders

- (2) Rear fenders
- (16) Plastic Rivets
- (2) M6 bolts
- (2) Washers

Standard Rear Fender Flares

- (2) Rear fenders
- (6) 1" bolts
- (2) 3/4" bolts
- (16) Small washers
- (2) Large washers
- (8) Lock nuts
- (8) Plastic Rivets