

2002-2008 Audi A4

Module Master

Instrument Panel Removal and Installation
2006 S Main St

Moscow, ID 83843

208-892-0764

Instrument Cluster

Special tools, testers and auxiliary items required

- ✘ Hook (3370)

Removing

- ✘ Do not disassemble instrument cluster.
 - **CAUTION!**
- ✘ **Switch ignition off and remove ignition key.**
- ✘ **Disconnect the battery Ground (GND) strap before working on the electrical system.**
 - Pull steering wheel with adjusting mechanism fully out and move it downward.
- ✘ For clarity, steering wheel is shown removed in the following illustrations.
 - Pull off bottom cover - **1** - towards rear - **arrows** -.

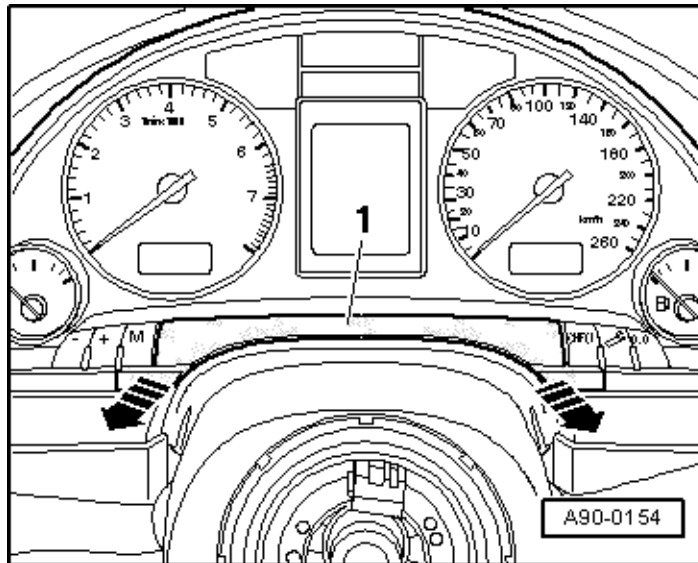

- Remove screws - **arrows** -.

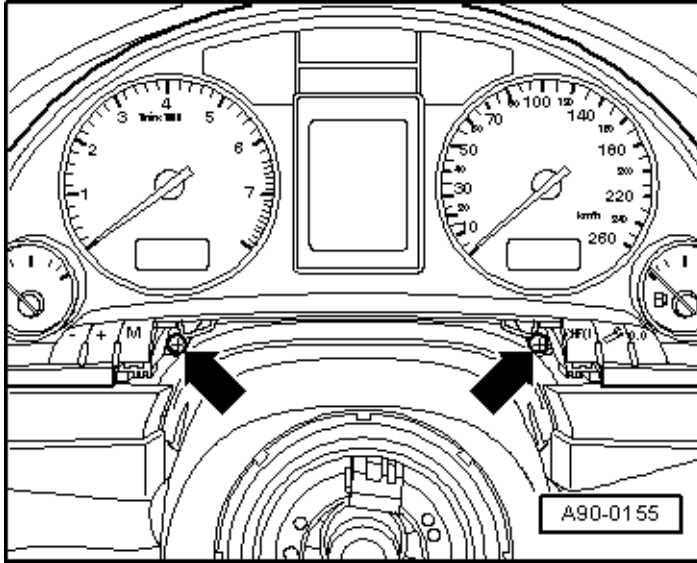

- Remove left instrument panel side cover - **arrow** - using hook (3370).

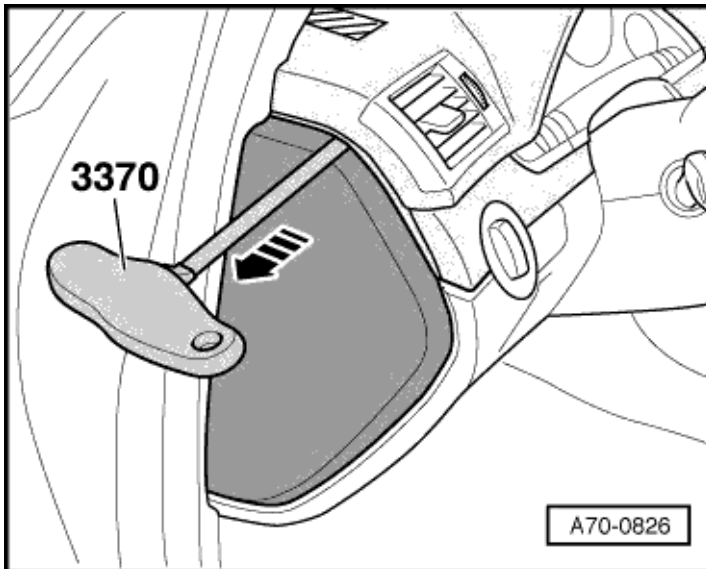

- Reach through opening - **arrow A** - above fuse panel and push out instrument cluster in direction of - **arrow B** -.

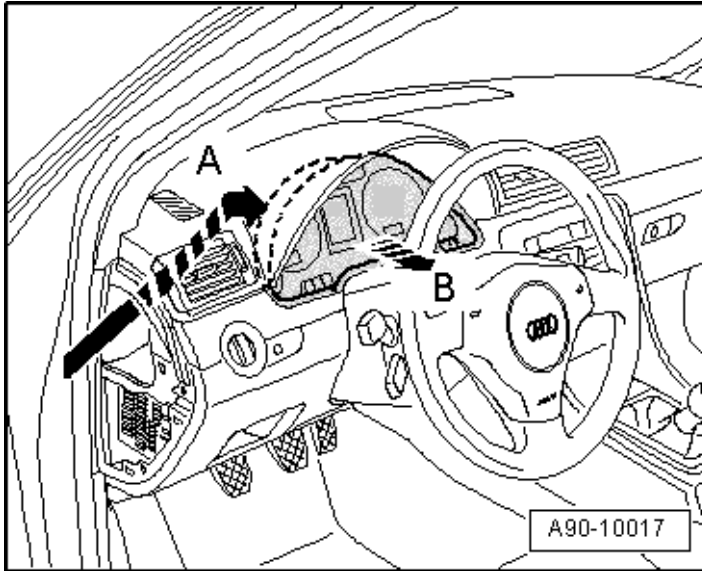

- Disengage lock on electrical connectors - **arrow** - and disconnect.

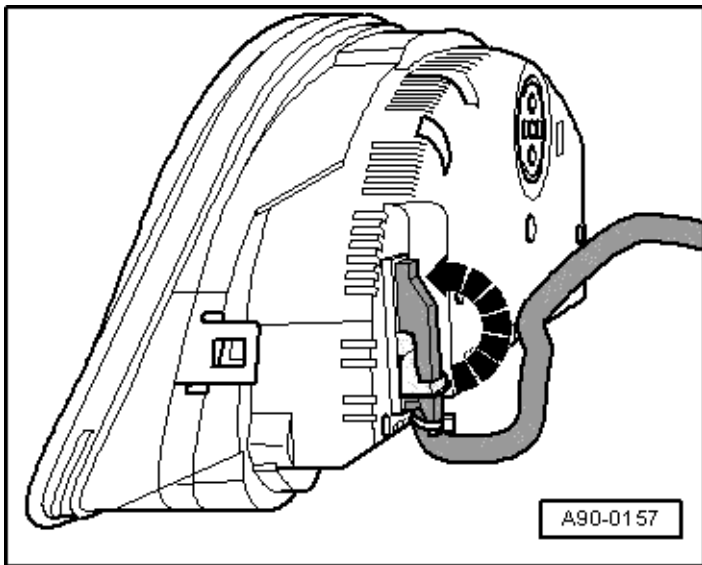

- Remove instrument cluster from instrument panel opening.

Installing

Install in reverse order of removal, noting the following:

- After installation, perform functional test of instrument cluster.
- If instrument cluster is replaced, continue to follow VAS 5051/5052 tester prompts in conjunction with OBD program option "Instrument cluster, replacing"
=> [OBD, Function]