

Wicker Sectional Sofa Set



Assembly Instructions

Made in Vietnam

The owner's manual contains important safety information as well as assembly, use and maintenance instructions. Keep the packaging and bags away from children and dispose of all packaging properly before use. Keep this manual for future reference.



**PLEASE DO NOT
RETURN THIS
PRODUCT
TO THE STORE**

We will be happy to correct any problems that you may have, or answer any of your questions regarding the purchase of this product. Please contact us at our Toll Free customer service number 1-800-599-8898 for any assistance and replacement parts. Thank You.



Dist. by TDC USA, Inc. Fairfield, NJ 07004
©2023 All Rights Reserved.
Made in Vietnam
Item 21746
www.tdcusainc.com

⚠ WARNING!

- Keep all children and pets away from assembly area. Children and pets should be supervised when they are in the area of the product construction.
- Some parts may contain sharp edges. When assembling and using this product, basic safety precautions should always be.
- Please read all the instructions and warnings before assembling. In order to make the whole product adjust to the best, please install all the screws on the product and tighten all the screws after adjusting the product which can stand on the floor even. Not intended for commercial use.
- Check all bolts for tightness before use.
- **IMPORTANT** - check and tighten bolts often to keep them secure

• **CHOKING HAZARD** - Small parts. Not suitable for children under 36 months. The product contains small parts, keep children away when assembling.

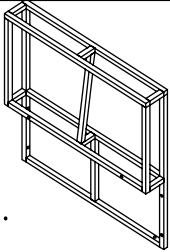
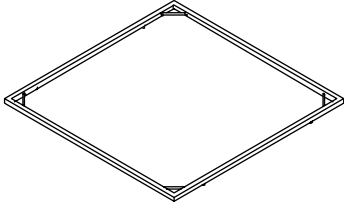
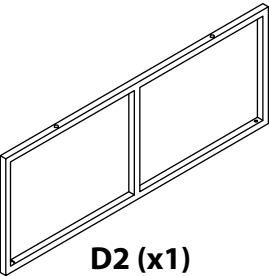
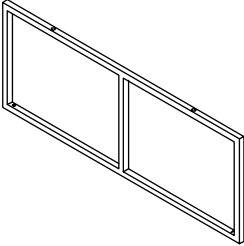
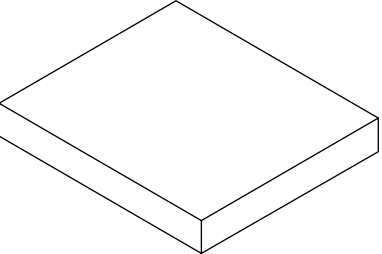
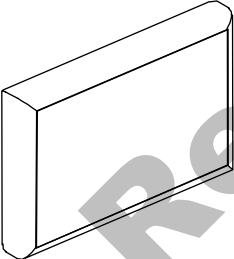
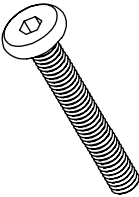
• **ADULT ASSEMBLY REQUIRED.**
Always remove protective material and poly bags and dispose before assembly.

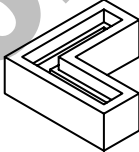
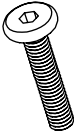
 <p>E1 (x1) Chair Back</p>	 <p>E2 (x1) Chair Seat</p>			
 <p>D2 (x1) Front Panel</p>	 <p>A4 (x2) Side Panel</p>			
 <p>Seat Cushion (x1)</p>	 <p>Back Cushion (x1)</p>			
 <p>1 (x12) M6x35 Bolt</p>	 <p>2 (x12) Washer</p>	 <p>3 (x1) Hex Key</p>	 <p>4 (x4) Corner Foot</p>	 <p>5 (x8) M6x25 Bolt</p>

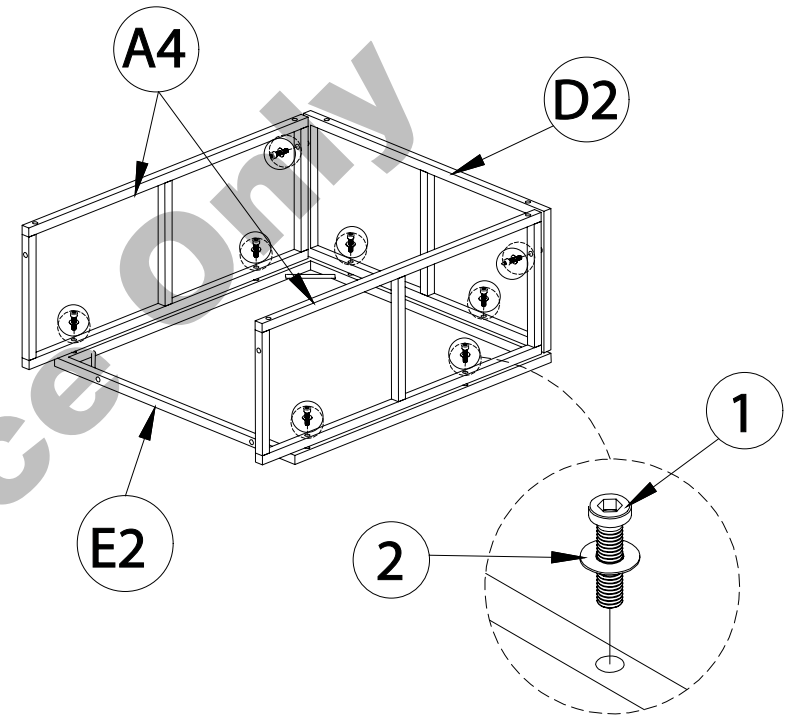

Step 1:

Set the Chair Seat (E2) upside-down on a soft, non-abrasive surface as illustrated here.

Insert two M6x35 Bolts (1) with Washers (2) through the eyelets at the top of Side Panel (A4), and into the bolt-threading found underneath Chair Seat (E2). **Do not tighten bolts down until you have completed Step 3 of assembly of this chair.** Place Front Panel (D2) next to previously assembled Side Panel (A4), and insert two M6x35 Bolts (1) with Washers (2) through the top of Front Panel (D2), and into the bolt-threading found underneath Chair Seat (E2).

Place a second Side Panel (A4) against previously assembled parts, and insert two M6x35 Bolts (1) with Washers (2) through the top of Side Panel (A4), and into the bolt-threading found underneath Chair Seat (E2).

Insert one M6x35 Bolts (1) through the eyelets at the ends of both Side Panels (A4), and into the bolt-threading at both ends of Front Panel (D2).

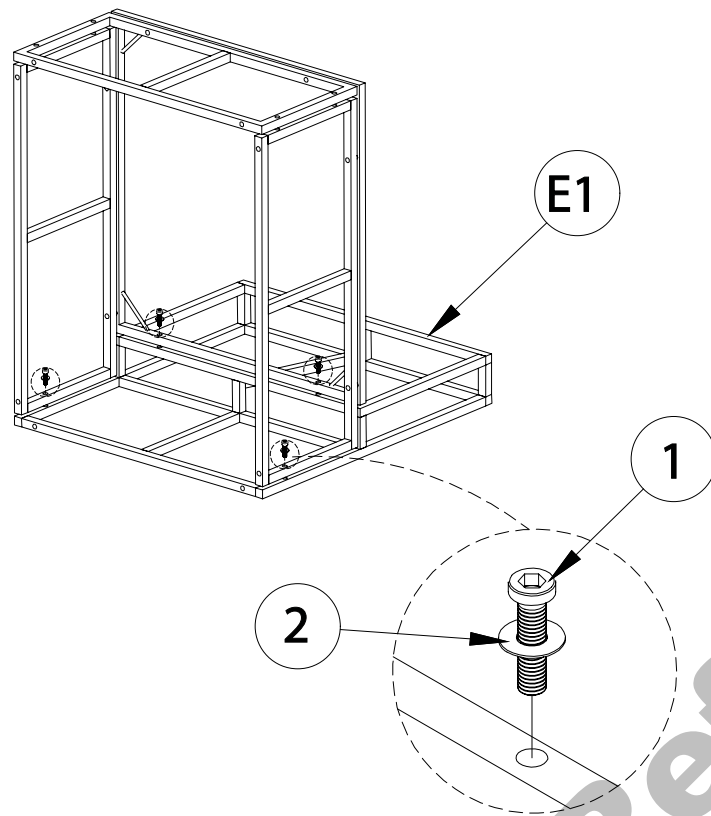

Step 2:

Set the Chair Back (E1) on a soft, non-abrasive surface as illustrated here. Place previously assembled parts on top as illustrated here.

Insert two M6x35 Bolts (1) with Washers (2) through eyelets found underneath Chair Seat (E2), and into bolt-threading found at the bottom of the chair's back of part E1.

Insert one M6x35 Bolt (1) with Washer (2) through each eyelet on the sides of both Side Panels (A4), and into the bolt-threading found at the bottom of Chair Back (E1).

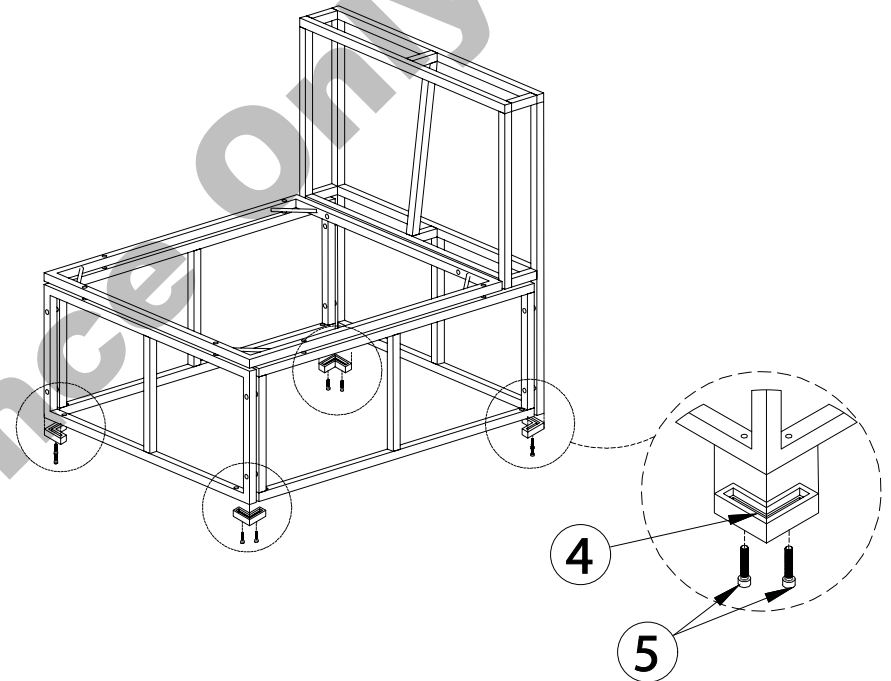

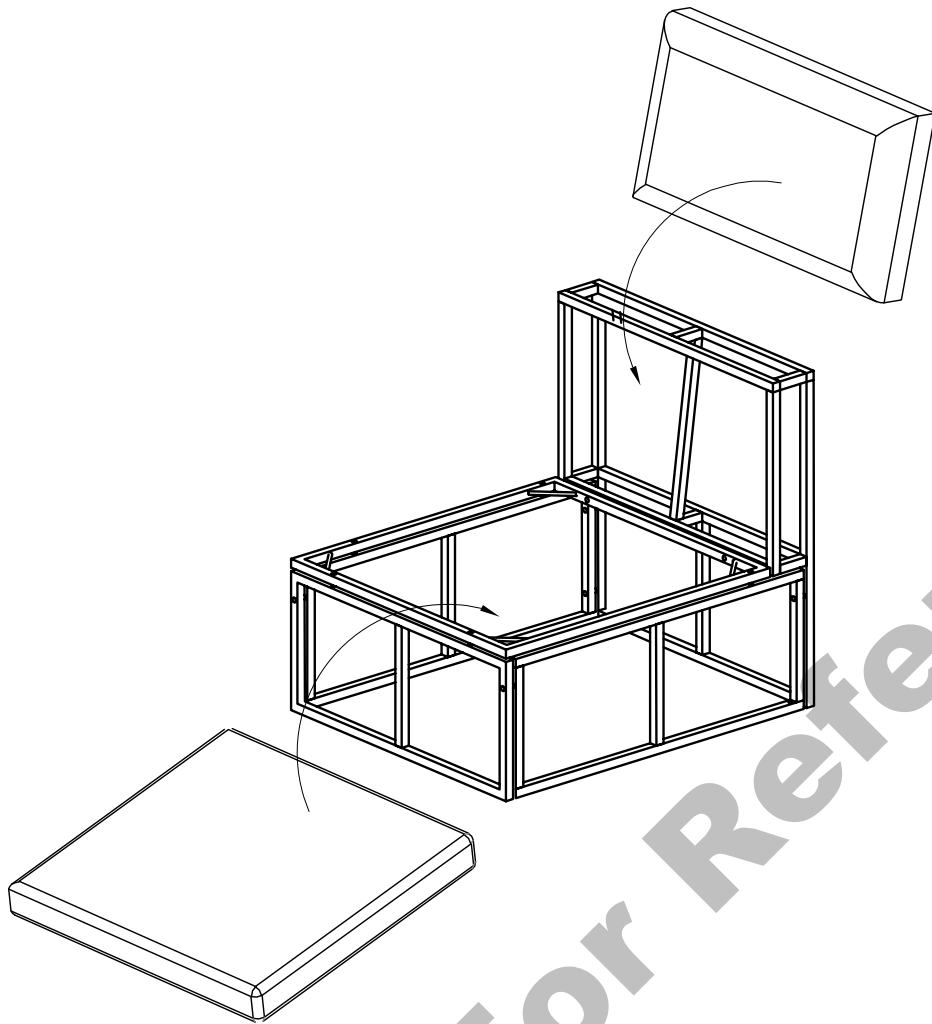

Step 3:

Place Corner Feet (4) at each corner of chair. Insert two M6x25 Bolts (5) through each Corner Foot (4), and into the bottoms of all previously assembled parts. Tighten all bolts left loose throughout assembly process using Hex Key (3). Turn the chair right-side up when finished.

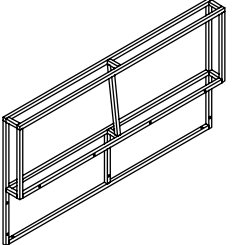
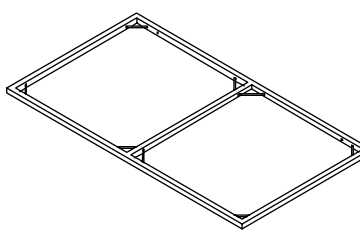
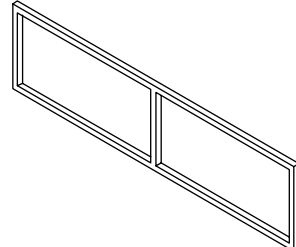
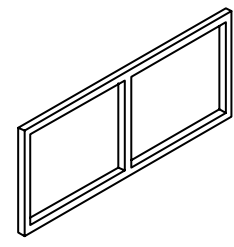
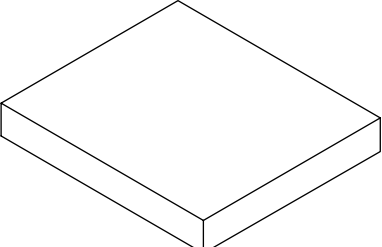
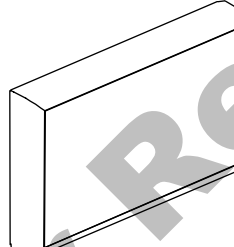
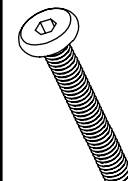

Step 4:

Place a seat cushion and back cushion on top when ready to use.

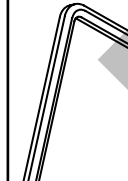
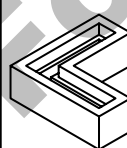
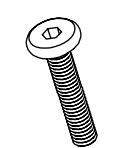
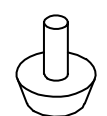
 <p>F1 (x1) Sofa Back</p>		 <p>F2 (x1) Sofa Seat</p>			
 <p>F3 (x1) Front Panel</p>		 <p>A4 (x3) Side Panel</p>			
 <p>Seat Cushion (x2)</p>		 <p>Back Cushion (x2)</p>			
 <p>1 (x16) M6x35 Bolt</p>	 <p>2 (x16) Washer</p>	 <p>3 (x1) Hex Key</p>	 <p>4 (x4) Corner Foot</p>	 <p>5 (x8) M6x25 Bolt</p>	 <p>6 (x2) Foot</p>

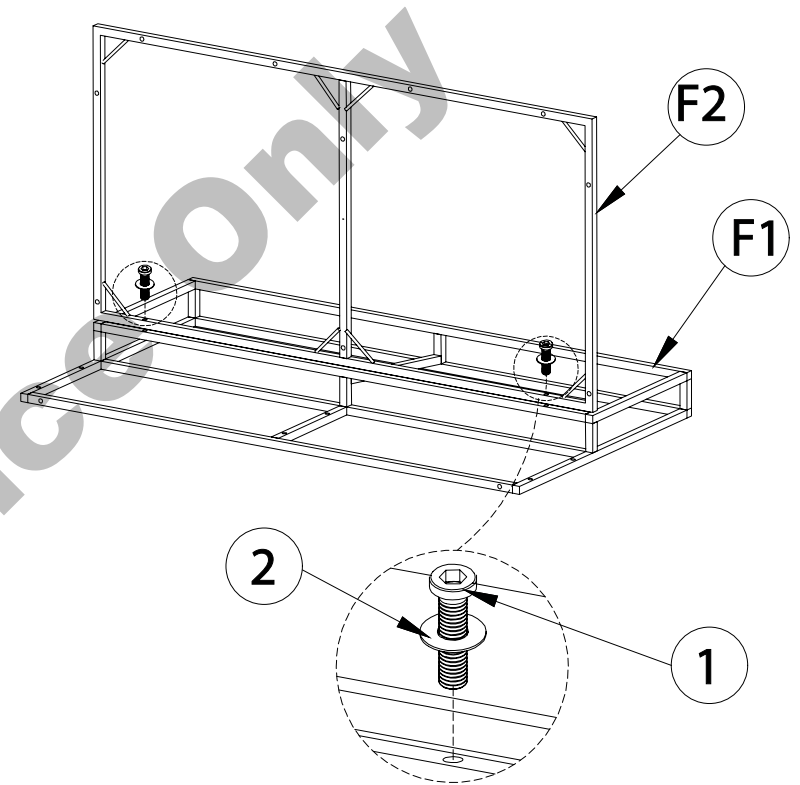

Step 1:

Set the Sofa Back (F1) on a soft, non-abrasive surface as illustrated here.

Insert two M6x35 Bolts (1) with Washers (2) through eyelets found underneath Sofa Seat (F2), and into bolt-threading found at the bottom of the sofa's back of part F1. **Do not tighten bolts down until you have completed Step 3 of assembly of this sofa.**

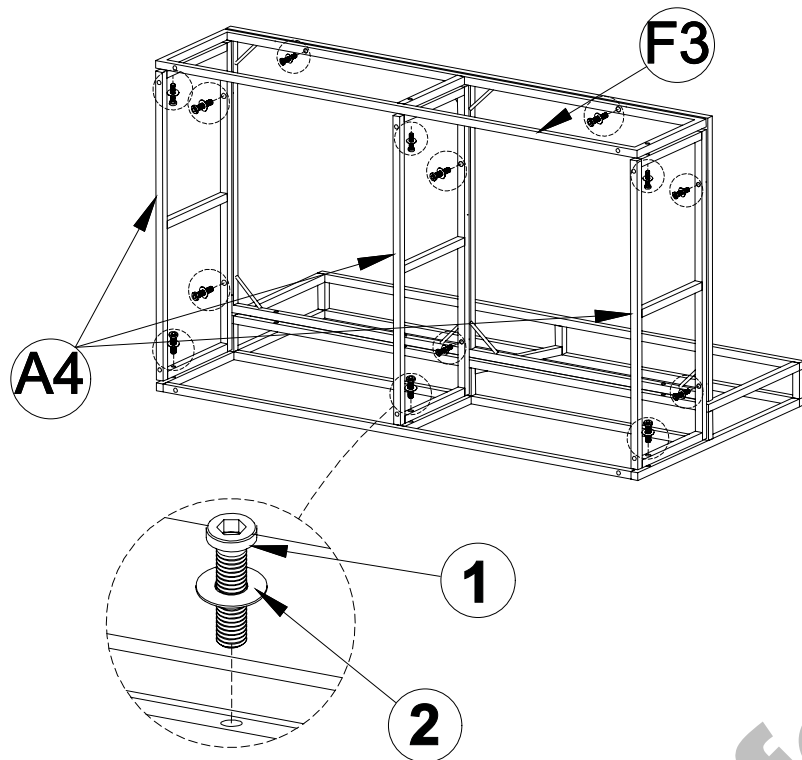

Step 2:

Insert two M6x35 Bolts (1) with Washers (2) through eyelets found on top of Side Panel (A4), and into bolt-threading found underneath Sofa Seat (F2). Follow this step to assemble two additional Side Panels (A4) in the center, and opposite side of Sofa Seat (F2).

Insert one M6x35 Bolt (1) with Washer (2) through the eyelet found on the side of Side Panel (A4), and into bolt-threading found at the bottom of Sofa Back (F1). Follow this step to connect the other Side Panels (A4) in the center, and on the opposite side of Sofa Seat (F2).

Insert one M6x35 Bolt (1) with Washer (2) through the eyelet found on the side of Side Panel (A4), and into bolt-threading found at the bottom of Front Panel (F3). Follow this step to connect the other Side Panels (A4) in the center, and on the opposite side of Front Panel (F3).

Insert two M6x35 Bolts (1) with Washers (2) through eyelets found on top of Front Panel (F3), and into bolt-threading found underneath Sofa Seat (F2).

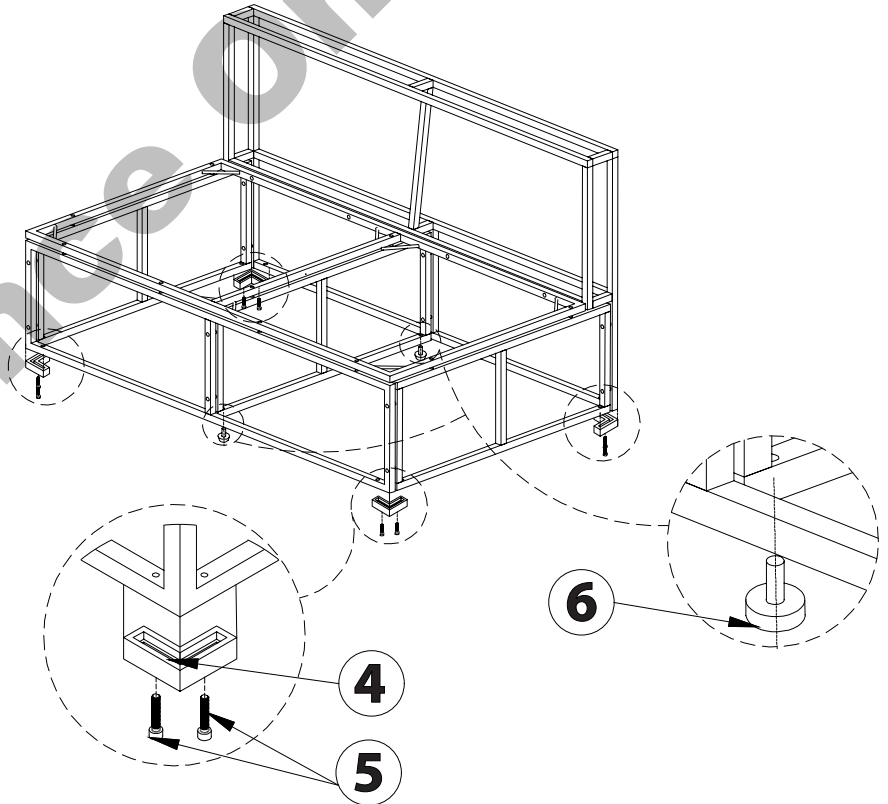



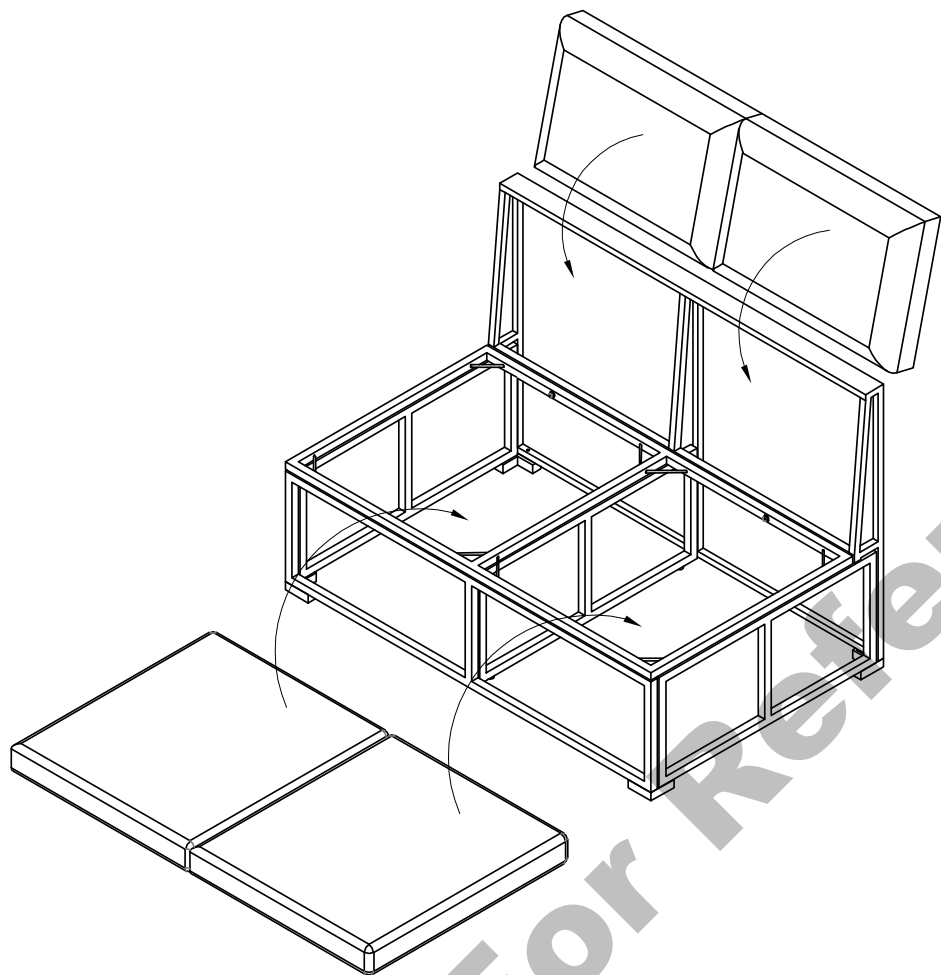

Step 3:

Place Corner Feet (4) at each corner of sofa. Insert two M6x25 Bolts (5) through each Corner Foot (4), and into the bottoms of all previously assembled parts. Tighten all bolts left loose throughout assembly process using Hex Key (3). Insert two Feet (6) into the bolt-threading on the bottom of the middle Side Panel (A4). Turn the sofa right-side up when finished.

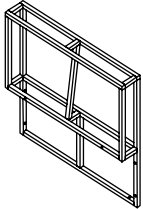
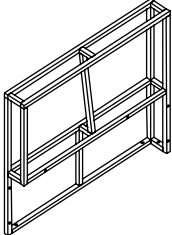
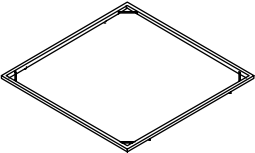
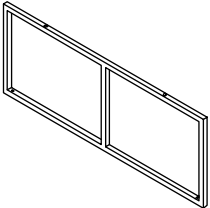
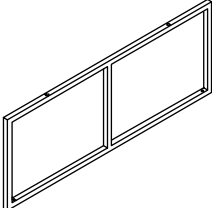
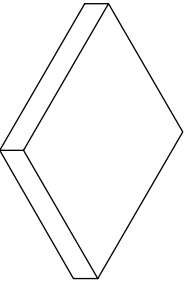
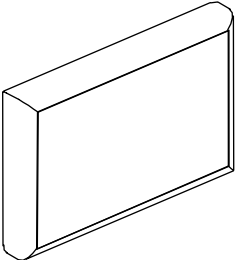
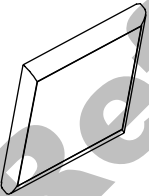
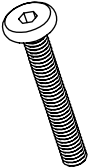

Step 4:

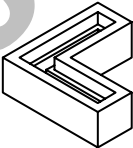
Place two seat cushions and two back cushions on top when ready to use.

 <p>A1 (x1) Left Corner Back</p>		 <p>A2 (x1) Right Corner Back</p>		
 <p>A3 (x1) Corner Panel</p>	 <p>A4 (x1) Side Panel</p>	 <p>A5 (x1) Side Panel</p>		
 <p>Seat Cushion (x1)</p>	 <p>Back Cushion (x1)</p>	 <p>Side Cushion (x1)</p>		
 <p>1 (x13) M6x35 Bolt</p>	 <p>2 (x13) Washer</p>	 <p>3 (x1) Hex Key</p>	 <p>4 (x4) Corner Foot</p>	 <p>5 (x8) M6x25 Bolt</p>

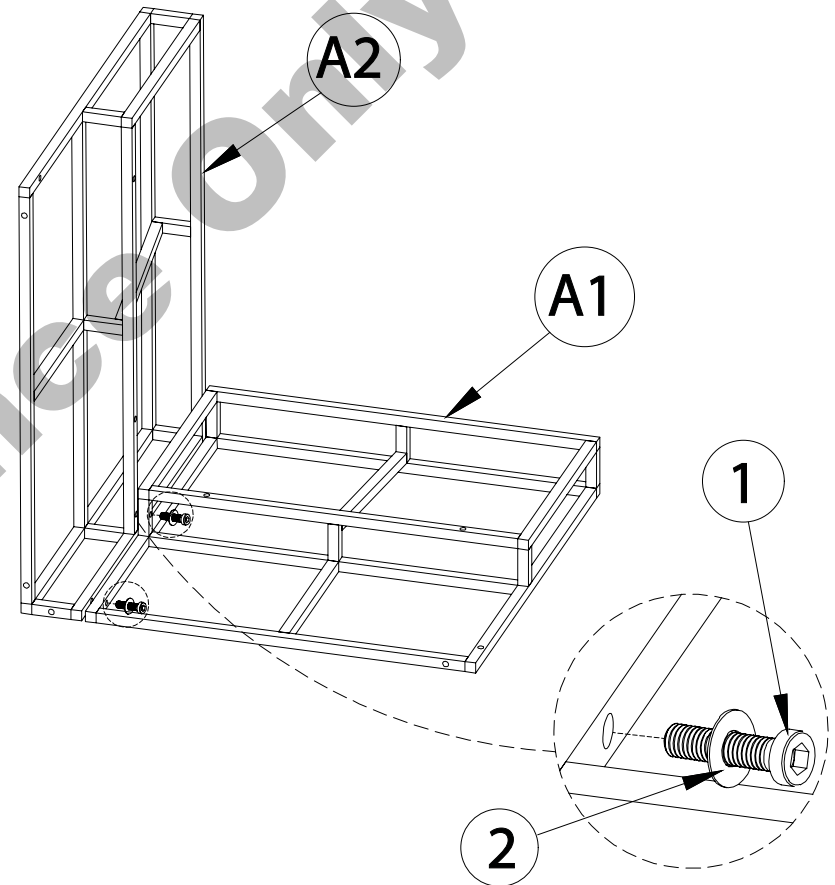

Step 1:

Bring Left Corner Back (A1) and Right Corner Back (A2) together as illustrated here. Insert two M6x35 Bolts (1) with Washers (2) through the eyelets at the bottom of Left Corner Back (A1), and into bolt-threading found at the bottom of Right Corner Back (A2). **Do not tighten bolts down until you have completed Step 3 of assembly of this chair.**

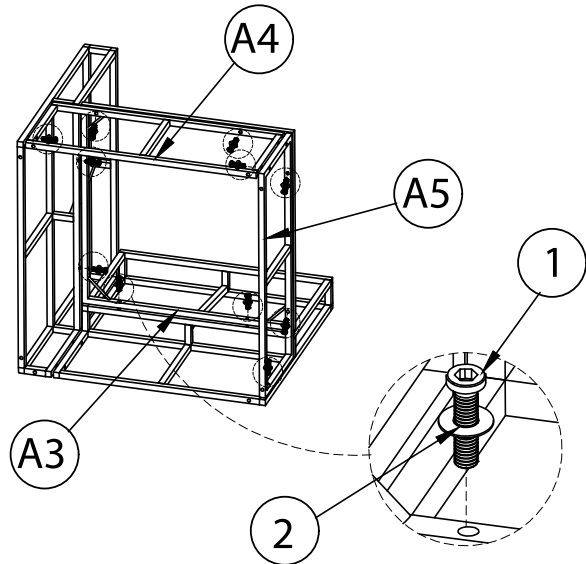

Step 2:

Insert two M6x35 Bolts (1) with Washers (2) through eyelets found underneath Corner Seat (A3), and into bolt-threading found at the bottom of the chair's back of part (A1).

Insert two M6x35 Bolts (1) with Washers (2) through eyelets found underneath Corner Seat (A3), and into bolt-threading found at the bottom of the chair's back of part (A2).

Insert two M6x35 Bolts (1) with Washers (2) through eyelets at the top of Side Panel (A5), and into the bolt-threading found underneath Corner Seat (A3).

Insert two M6x35 Bolts (1) with Washers (2) through eyelets at the top of Side Panel (A4), and into the bolt-threading found underneath Corner Seat (A3).

Insert one M6x35 Bolt (1) with Washer (2) through eyelet on the side of Side Panel (A5), and into the bolt-threading found at the bottom of Left Corner Back (A1).

Insert one M6x35 Bolt (1) with Washer (2) through eyelet on the side of Side Panel (A4), and into the bolt-threading found at the bottom of Right Corner Back (A2).

Insert one M6x35 Bolt (1) with Washer (2) through eyelet on the other side of Side Panel (A4), and into the bolt-threading found at the other end of Side Panel (A5).

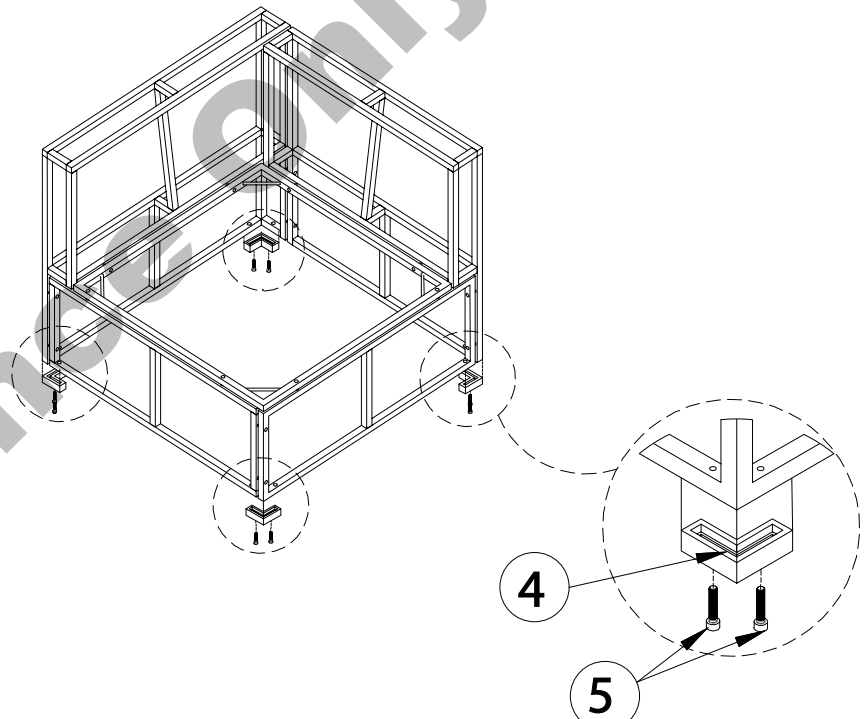

Step 3:

Place Corner Feet (4) at each corner of corner chair. Insert two M6x25 Bolts (5) through each Corner Foot (4), and into the bottoms of all previously assembled parts. Tighten all bolts left loose throughout assembly process using Hex Key (3). Turn the corner chair right-side up when finished.

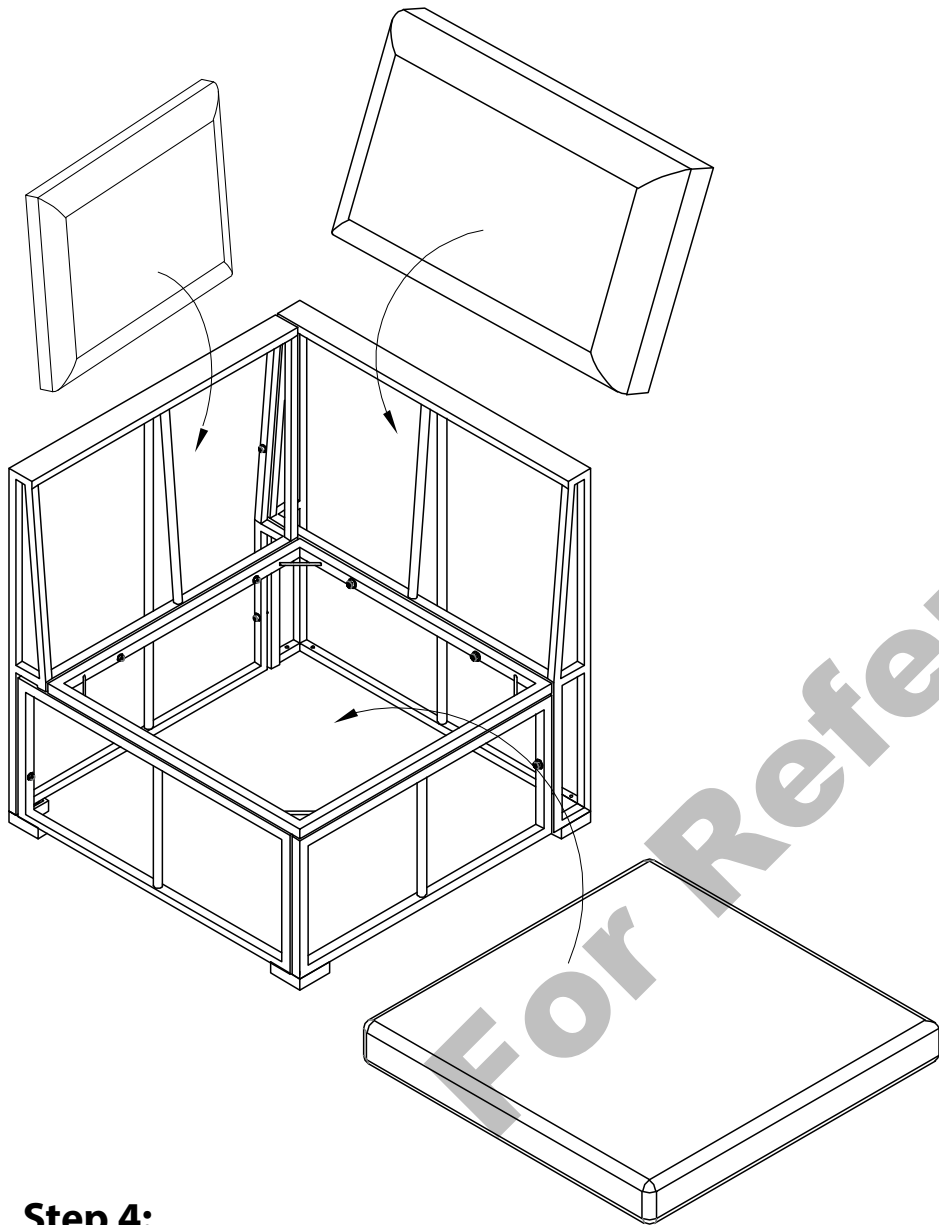

Step 4:

Place one seat cushion, one back cushion, and one side cushion on top when ready to use.

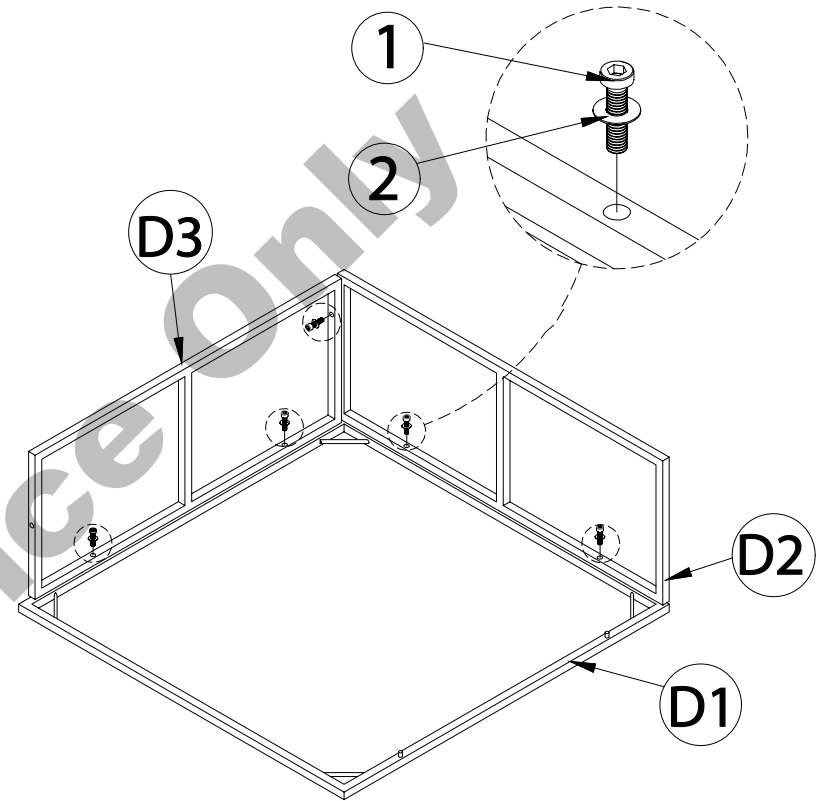
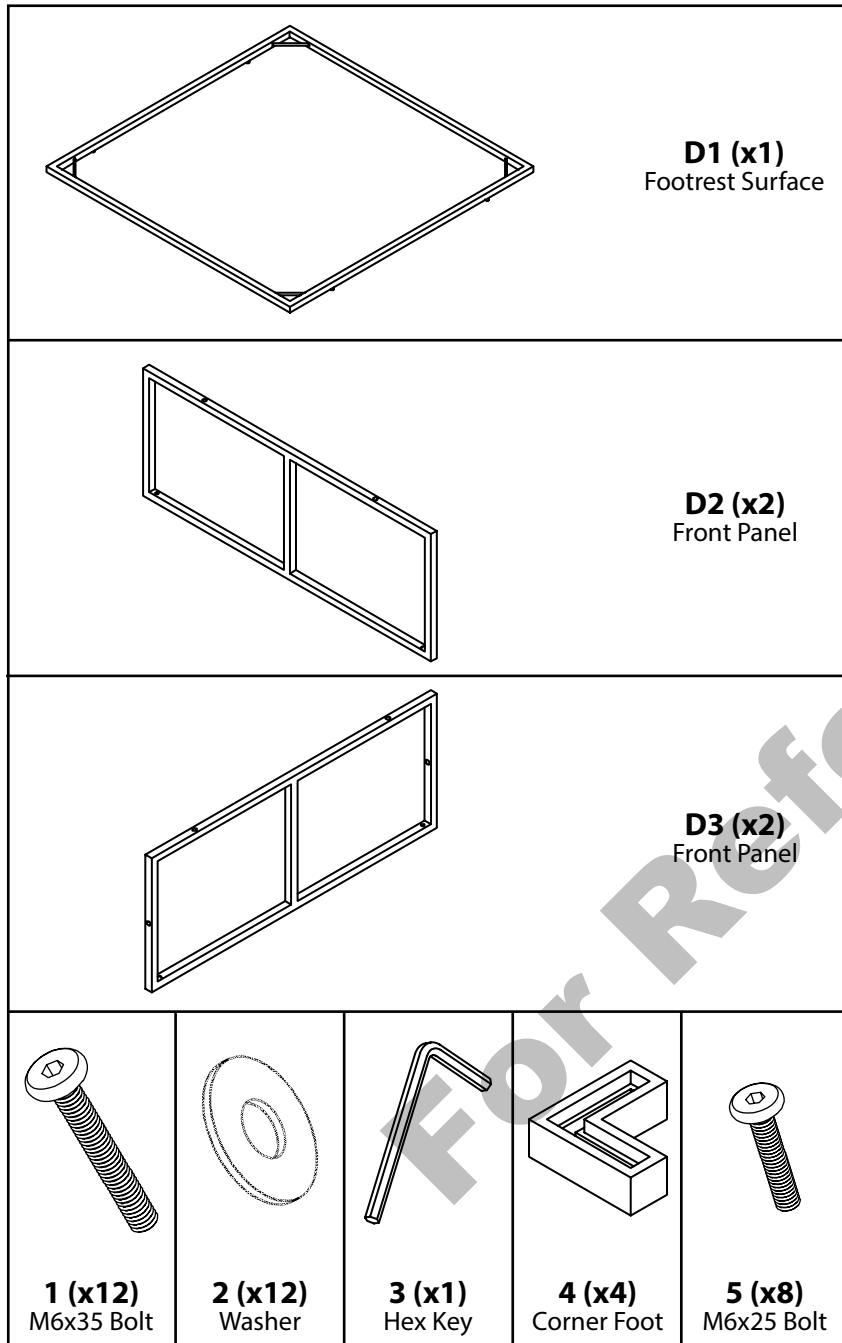

Step 1:

Set the Footrest Surface (D1) upside-down on a soft, non-abrasive surface as illustrated here.

Insert two M6x35 Bolts (1) with Washers (2) through the eyelets on top of Front Panel (D2), and into the bolt-threading found underneath Footrest Surface (D1).

Insert two M6x35 Bolts (1) with Washers (2) through the eyelets on top of Front Panel (D3), and into the bolt-threading found underneath Footrest Surface (D1).

Insert one M6x35 Bolt (1) with Washer (2) through the eyelet on the side of Front Panel (D3), and into the bolt-threading at the end of Front Panel (D2). **Do not tighten bolts down until you have completed Step 3 of assembly of this footrest.**

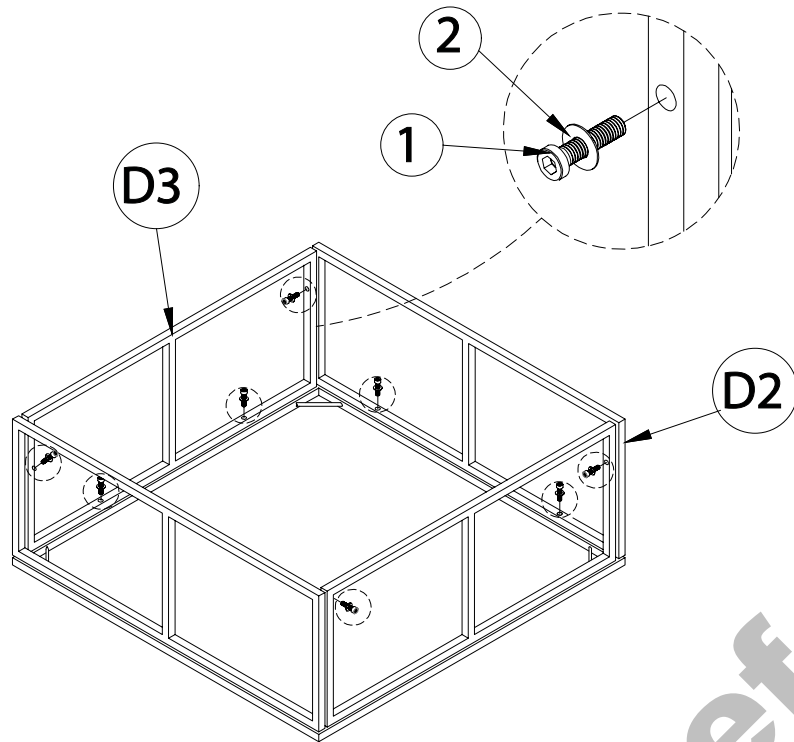

Step 2:

Place second Front Panel (D2) next to the previously assembled Front Panel (D3). Insert two M6x35 Bolts (1) with Washers (2) through the eyelets on top of Front Panel (D2), and into the bolt-threading found underneath Footrest Surface (D1). Place second Front Panel (D3) next to both previously assembled Front Panels (D2).

Insert two M6x35 Bolts (1) with Washers (2) through the eyelets on top of Front Panel (D3), and into the bolt-threading found underneath Footrest Surface (D1).

Insert one M6x35 Bolt (1) with Washer (2) through each eyelet on each side of both Front Panels (D3), and into the bolt-threading at the ends of both Front Panels (D2).

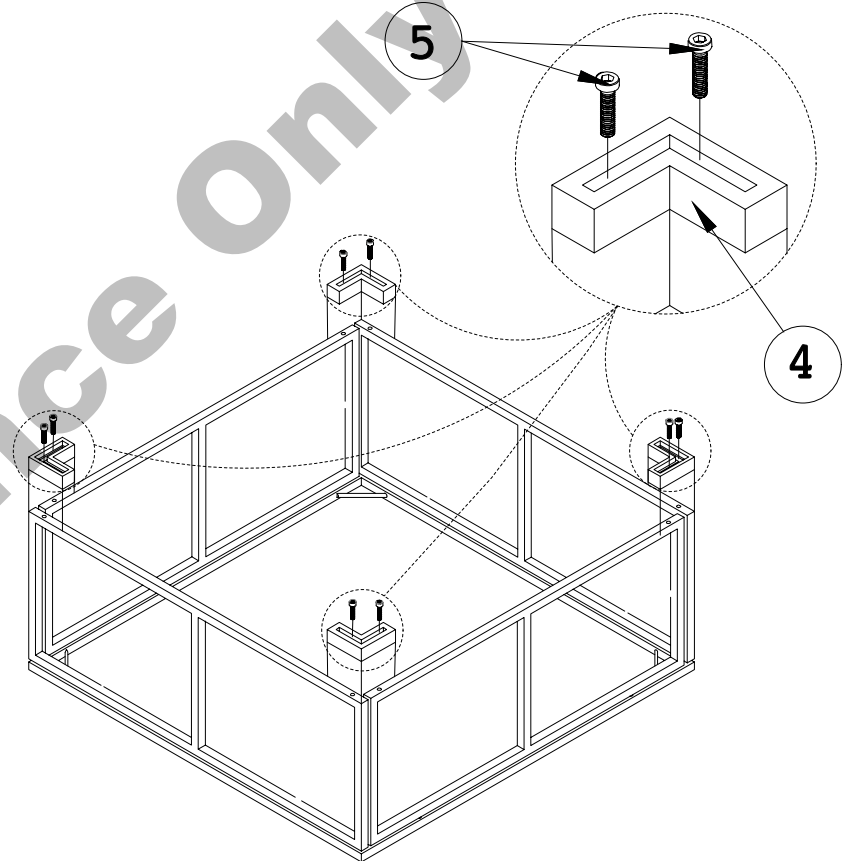

Step 3:

Place Corner Feet (4) at each corner of footrest. Insert two M6x25 Bolts (5) through each Corner Foot (5), and into the bottoms of all previously assembled parts. Tighten all bolts left loose throughout assembly process using Hex Key (3).

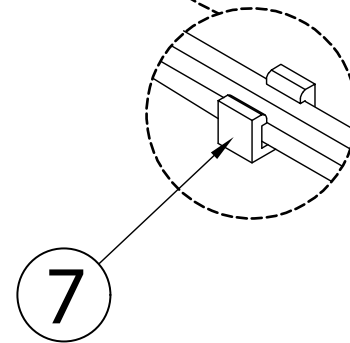
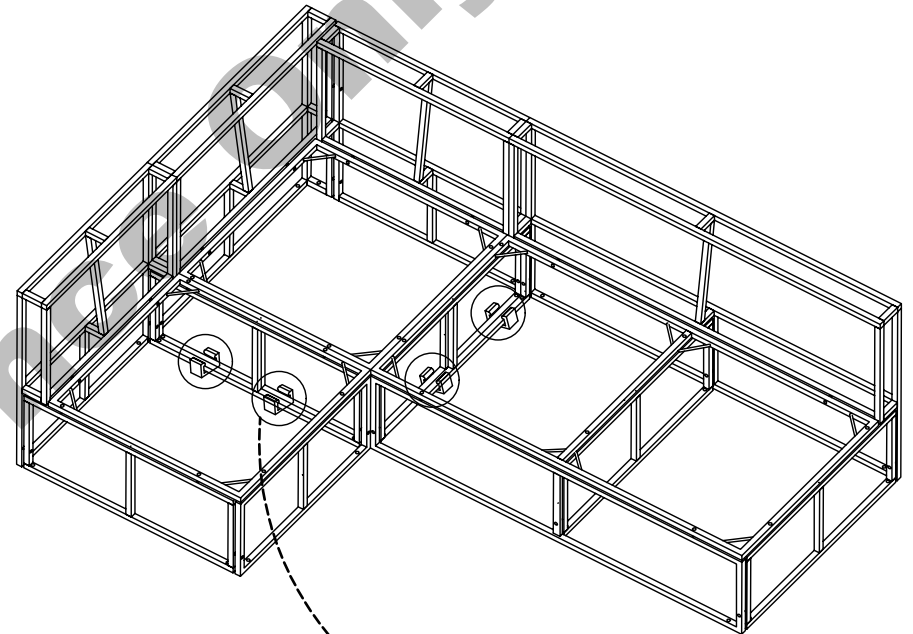
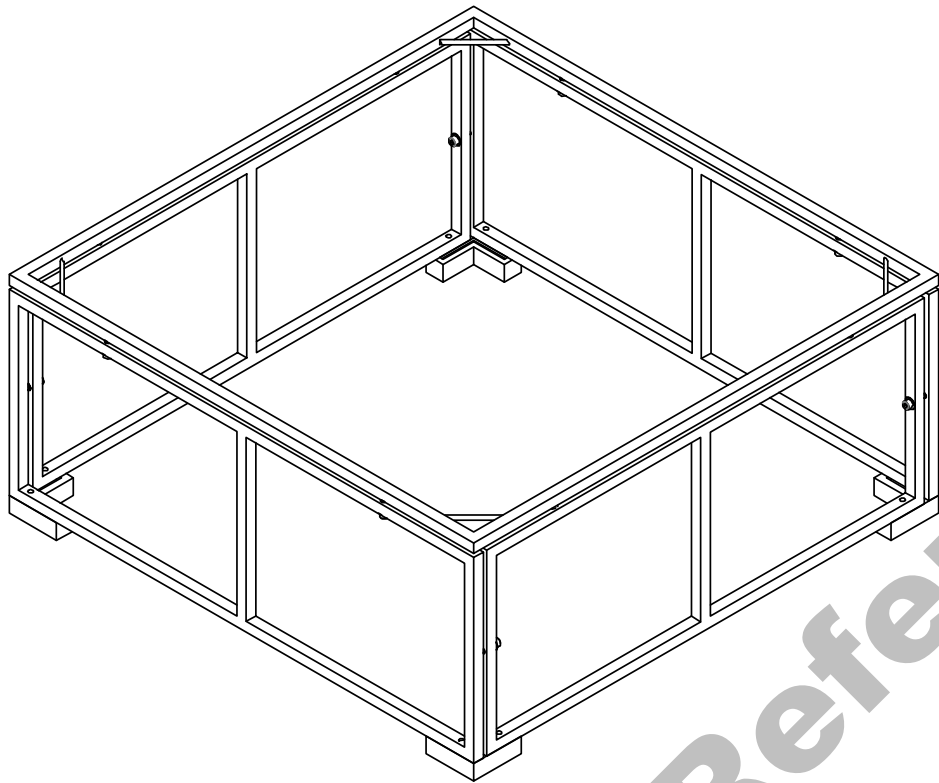

Step 4:

Turn the footrest right-side up when finished.

Finish:

Use two Clamps (7) to lock the chair to the corner chair by placing them over the frames of both seats. Use remaining two Clamps (7) to lock the opposite side of the

Wicker Sectional Sofa Set

Dist. by TDC USA, Inc. Fairfield, NJ 07004
©2023 All Rights Reserved. Made in Vietnam.
Item #21746

Questions and Comments
1-800-599-8898 (9 am - 5 pm EST)
www.tdcusainc.com