

Wicker Patio Conversation Set



Assembly Instructions

Made in China

The owner's manual contains important safety information as well as assembly, use and maintenance instructions. Keep the packaging and bags away from children and dispose of all packaging properly before use. Keep this manual for future reference.



**PLEASE DO NOT
RETURN THIS
PRODUCT
TO THE STORE**

We will be happy to correct any problems that you may have, or answer any of your questions regarding the purchase of this product. Please contact us at our Toll Free customer service number 1-800-599-8898 for any assistance and replacement parts. Thank You.













Dist. by TDC USA, Inc. Fairfield, NJ 07004
©2023 All Rights Reserved.
Made in China
Item 22561
www.tdcusainc.com

⚠ WARNING!

- Keep all children and pets away from assembly area. Children and pets should be supervised when they are in the area of the product construction.
- Some parts may contain sharp edges. When assembling and using this product, basic safety precautions should always be.
- Please read all the instructions and warnings before assembling. In order to make the whole product adjust to the best, please install all the screws on the product and tighten all the screws after adjusting the product which can stand on the floor even. Not intended for commercial use.
- Check all bolts for tightness before use.
- **IMPORTANT** - check and tighten bolts often to keep them secure

• **CHOKING HAZARD** - Small parts. Not suitable for children under 36 months. The product contains small parts, keep children away when assembling.

• **ADULT ASSEMBLY REQUIRED.**
Always remove protective material and poly bags and dispose before assembly.

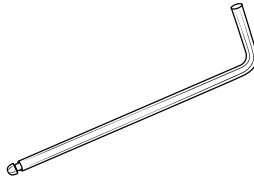
| | | | |
|---|--------------------------------|---|--------------------------------|
|  | A (x2) Chair Back |  | B (x2) Chair Seat |
|  | C (x3) Left Armrest |  | D (x3) Right Armrest |
|  | E (x1) Sofa Back |  | F (x1) Sofa Seat |
|  | G (x2) Chair Cushion |  | H (x2) Table Legs |
|  | I (x1) Sofa Cushion |  | J (x2) Table Panel |
|  | K (x1) Glass |  | L (x43) M6x35 Bolt |
|  | M (x43) Washers |  | N (x1) Hex Key |

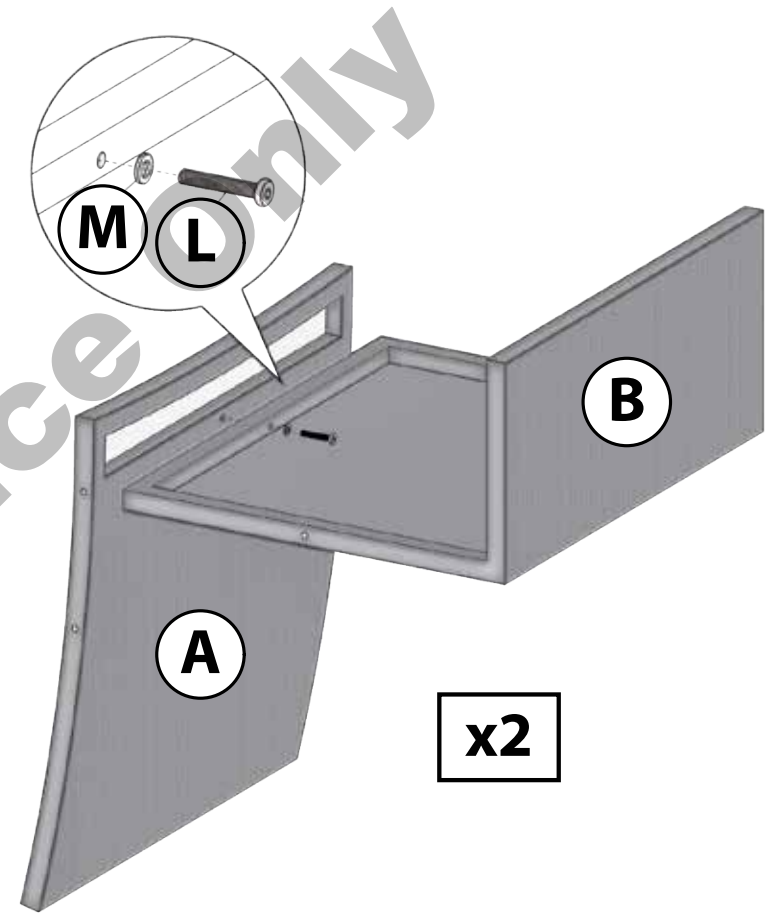

Step 1:

Bring Chair Back (A) and Chair Seat (B) together as illustrated here.

Insert one M6x35 Bolt (L) with Washer (M) through the back eyelet underneath Chair Seat (B), and into the bolt-threading found at the bottom of Chair Back (A). **Do not tighten bolts down until you have completed Step 3 of assembly of this chair.**

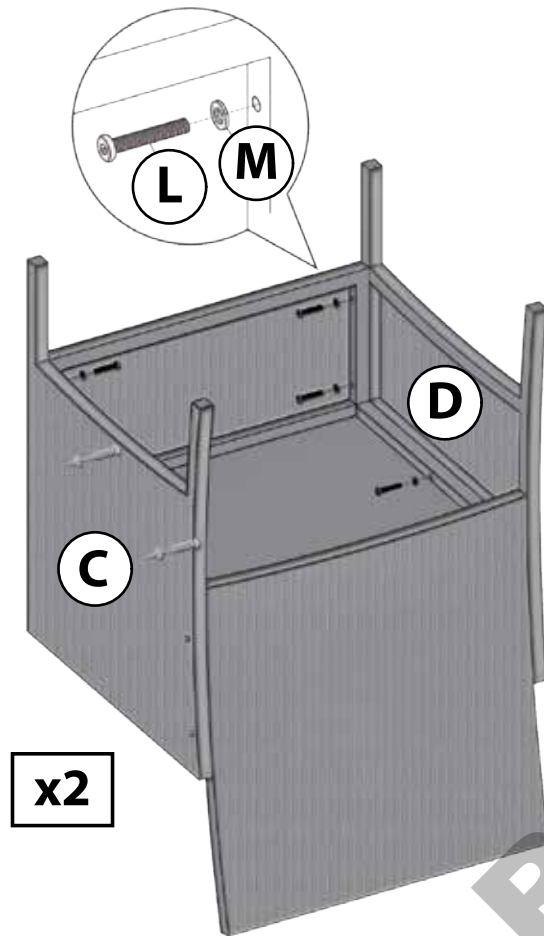

Step 2:

Place Left Armrest (C) on the left side of previously assembled parts as illustrated here.

Insert one M6x35 Bolt (L) with Washer (M) through the side eyelet underneath Chair Seat (B), and into the bolt-threading at the center of the center-horizontal bar of Left Armrest (C).

Insert two M6x35 Bolts (L) with Washers (M) through the two eyelets underneath the Chair Seat's (B) front panel, and into the two bolt-threading found on the side of the front leg of Left Armrest (C). Follow these steps to assemble the Right Armrest (D) to the right side of the chair.



Step 3:

Turn the chair right-side up when finished.

Insert two M6x35 Bolts (L) with Washers (M) through the two eyelets on the outside, back leg of Left Armrest (C), and into the two bolt-threading found on the side of Chair Back (A). Follow this step to finish assembly of the Right Armrest (D) on the opposite side of the chair. Tighten all bolts left loose throughout assembly process using Hex Key (N).

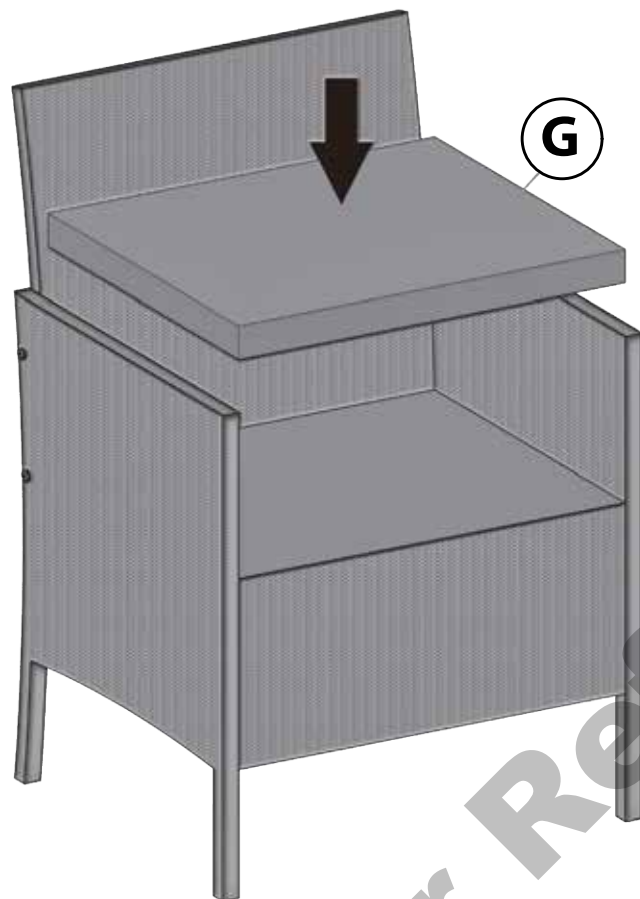
**Step 4:**

Place Chair Cushion (G) onto the seat when finished. The chair is now ready to use.

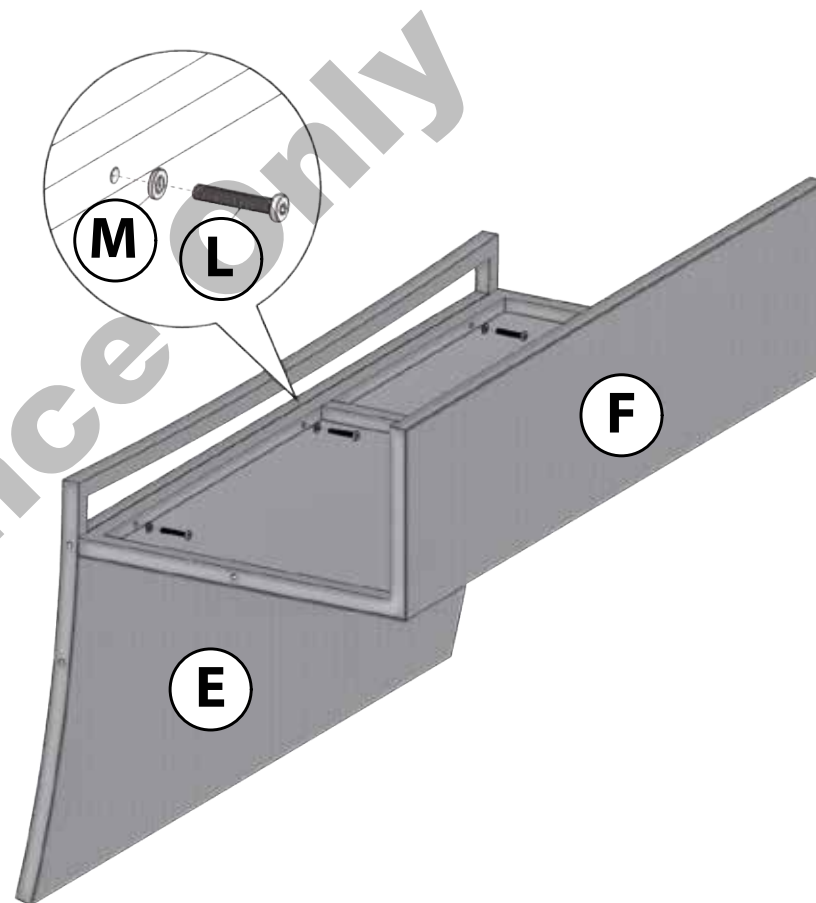
**Step 5:**

Bring Sofa Back (E) and Sofa Seat (F) together as illustrated here.

Insert three M6x35 Bolts (L) with Washers (M) through the back eyelets underneath Sofa Seat (F), and into the bolt-threading found at the bottom of Sofa Back (E). **Do not tighten bolts down until you have completed Step 7 of assembly of this sofa.**

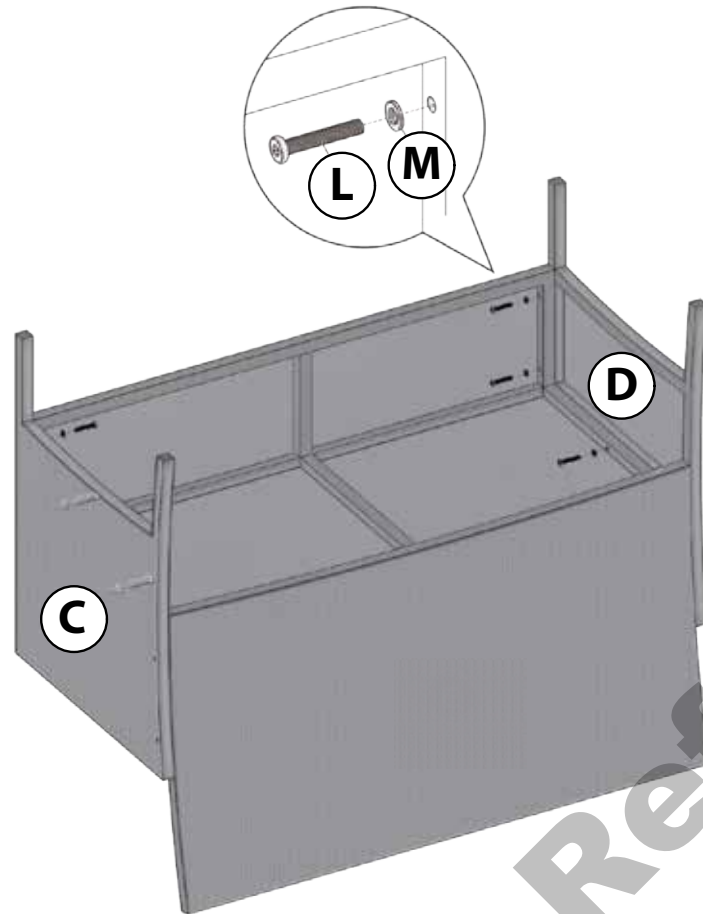
**Step 6:**

Place Left Armrest (C) on the left side of previously assembled parts as illustrated here. Insert one M6x35 Bolt (L) with Washer (M) through the side eyelet underneath Sofa Seat (F), and into the bolt-threading at the center of the center-horizontal bar of Left Armrest (C).

Insert two M6x35 Bolts (L) with Washers (M) through the two eyelets underneath the Sofa Seat's (F) front panel, and into the two bolt-threading found on the side of the front leg of Left Armrest (C). Follow these steps to assemble the Right Armrest (D) to the right side of the sofa.

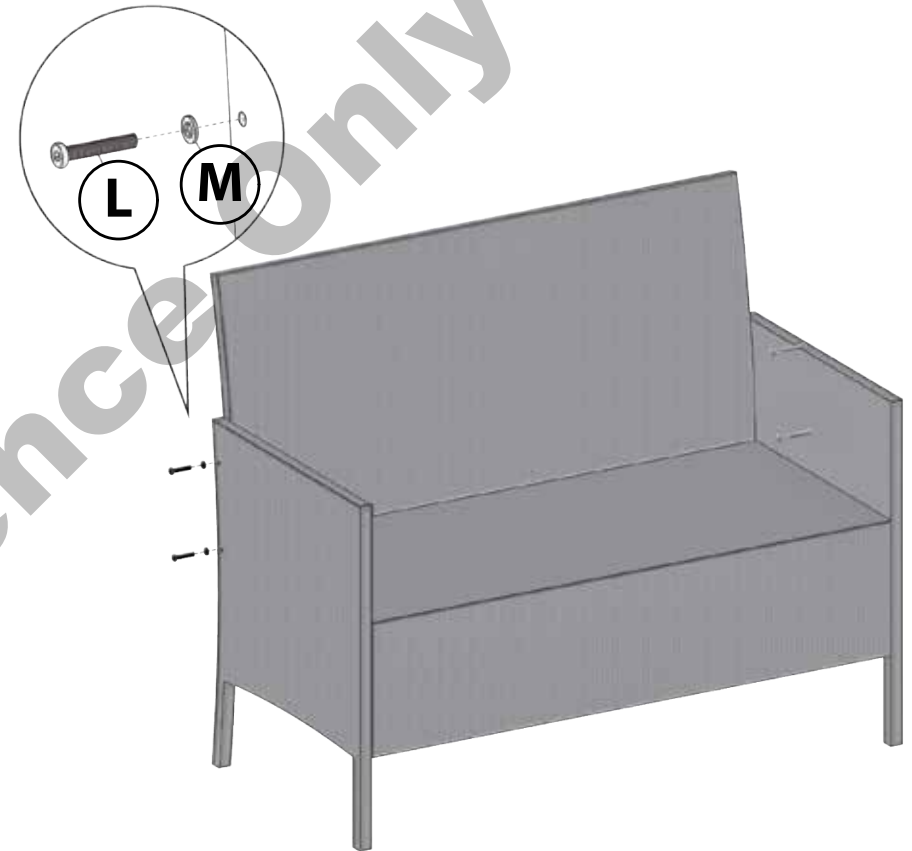
**Step 7:**

Turn the sofa right-side up when finished.

Insert two M6x35 Bolts (L) with Washers (M) through the two eyelets on the outside, back leg of Left Armrest (C), and into the two bolt-threading found on the side of Sofa Back (E). Follow this step to finish assembly of the Right Armrest (D) on the opposite side of the sofa. Tighten all bolts left loose throughout assembly process using Hex Key (N).

**Step 8:**

Place Sofa Cushion (I) onto the seat when finished. The sofa is now ready to use.

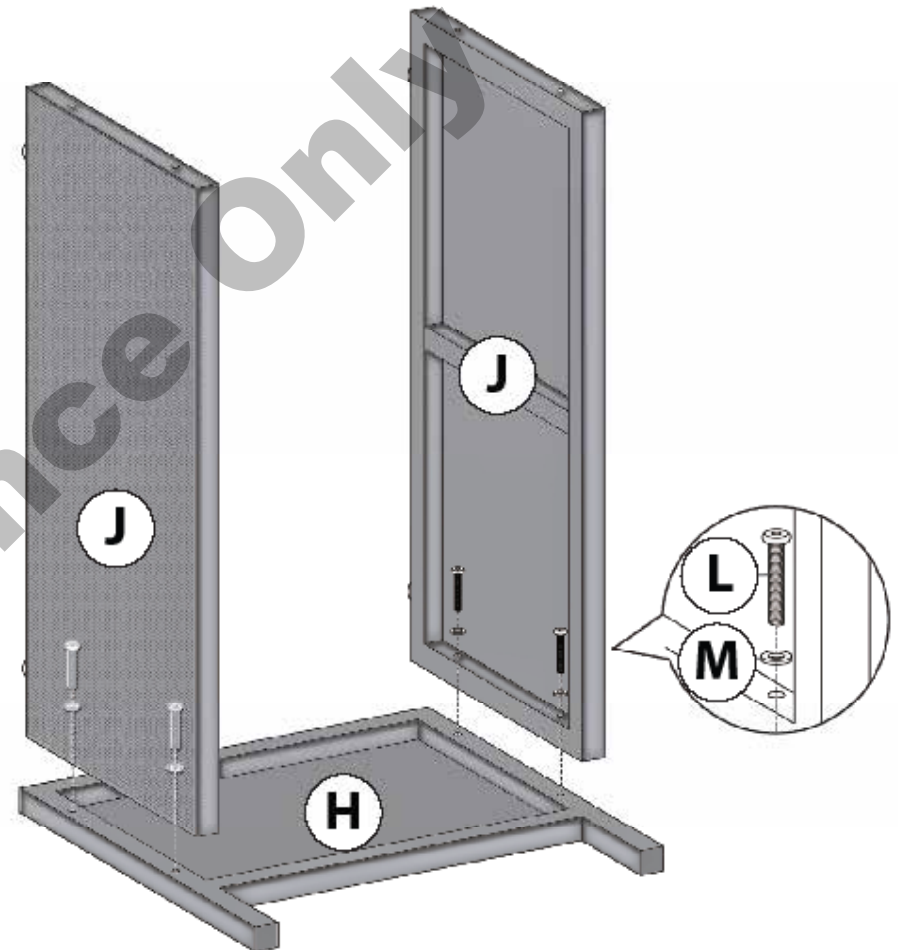
**Step 9:**

Place Table Legs (H) on a soft, non-abrasive surface as illustrated here.

Insert two M6x35 Bolts (L) with Washers (M) through the two eyelets on the side of inner wall of Table Panel (J), and into the bolt-threading found on leg of Table Legs (H). Follow this step to assemble the second Table Panel (J) to the other leg of Table Legs (H). **Do not tighten bolts down until you have completed Step 10 of assembly of this table.**

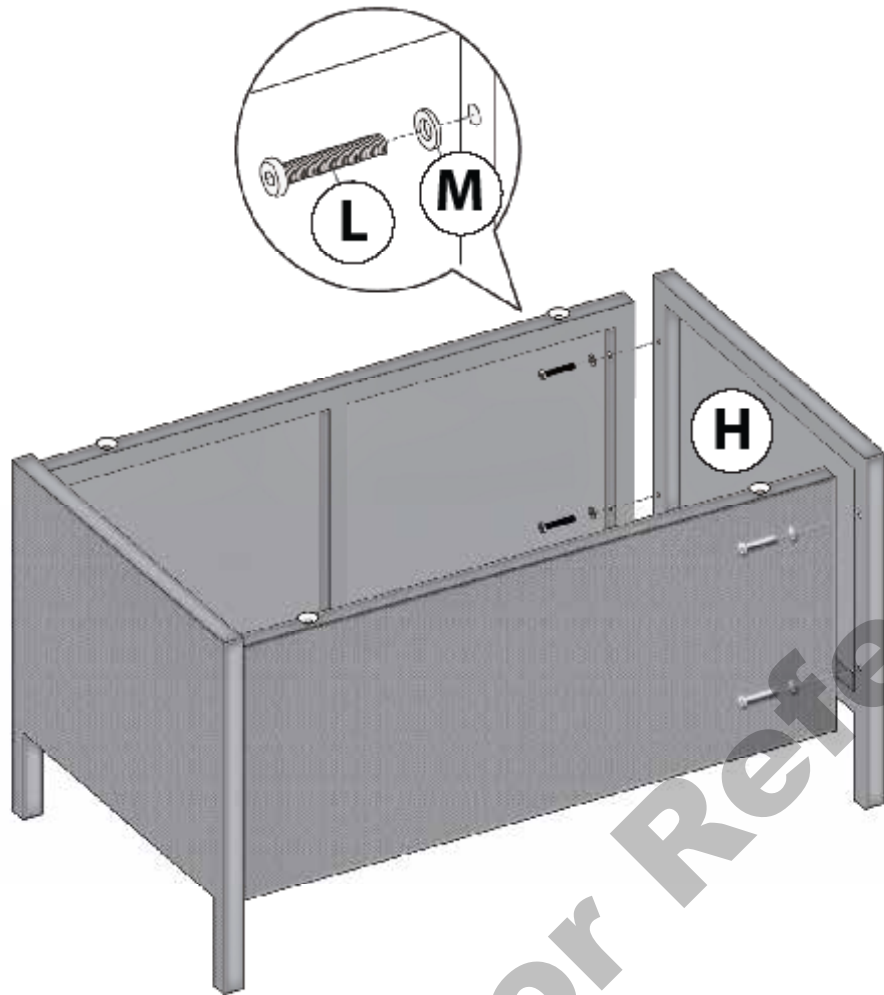
**Step 10:**

Insert two M6x35 Bolts (L) with Washers (M) through the two eyelets on the opposite side of inner wall of Table Panel (J), and into the bolt-threading found on leg of the second Table Legs (H). Follow this step to assemble the remaining Table Panel (J) to the other leg of the second Table Legs (H). Tighten all bolts left loose throughout assembly process using Hex Key (N).

**Step 11:**

Carefully place Glass (K) on top of Table Panels (J), in between both Table Legs (H). The suction cups found on top of both Table Panels (J) will help secure the glass in place. Your table is now ready to use.

LIMITED WARRANTY

Please contact our service hot-line by phone, email, or fax before sending the device. This allows us to provide support in the event of possible operator errors.

All furniture manufactured and sold by TDC USA, Inc. is warranted to the original purchaser against defects in workmanship and materials. If a product manufactured by TDC fails during the first year from date of purchase under the terms of our limited warranty, TDC will replace the item at no charge. After one year, it will be the original purchaser's responsibility to pay for freight and packing. TDC reserves the right, in the case of discontinued or out of production models, to replace with an item of similar quality. (Glass breakage is not warranted.)

NOTE: You must retain original receipt to obtain warranty!

FRAMES:

Frames are warranted against defects in materials and workmanship from the date of original purchase. Damage to frames or welds due to commercial use, improper assembly, exposure to water and sub-freezing temperatures, and/or abuse are not covered.

FABRIC:

Fabric on cushions, slings, and umbrellas is warranted against separation at the seams. Fading, mildew, and/or discoloration due to exposure to elements, chemicals, and spills are not covered.

POWDER COAT AND/OR PAINT:

The finish is warranted against blistering, peeling, or cracking. Fading resulting from exposure to the elements, chemicals, and spills are not covered. Scratches and chips due to normal wear and use are not covered.

FREIGHT & PACKING:

TDC will be responsible for shipping, handling, and packaging charges for all valid warranty claims.

CARE & MAINTENANCE:

Be careful to never allow water build up in frames as this will cause corrosion and freeze damage in cold climates. Wash all frames with a solution of mild soap and water. Rinse with clean water and dry with a soft absorbent cloth towel. Frames can be treated with a liquid wax for maximum protection against UV rays and/or salty damp air. If your set includes cushions, slings, and/or an umbrella, they may be cleaned by hand with a solution of soap and water with a clean water rinse.

LIMITED WARRANTY EXCLUSIONS:

- Damage caused by acts of nature
- Wind damage
- Failure caused by unreasonable, unanticipated, or abusive use
- Failure caused by a lack of reasonable and necessary care and maintenance
- Normal fade of fabrics, upholstery, or woven materials
- Glass table tops
- Bursting or cracking of tubing due to exposure to water and freezing temperatures
- Changes in wood color due to the natural aging of the wood

Lack of original receipt will void warranty

Customer Service:

Monday - Friday • 9:00 am - 5:00 pm

Phone: 800-599-8898

Email: support@tdcusainc.com

Wicker Patio Conversation Set

Dist. by TDC USA, Inc. Fairfield, NJ 07004
©2023 All Rights Reserved. Made in China.
Item #22561

Questions and Comments
1-800-599-8898 (9 am - 5 pm EST)
www.tdcusainc.com