

Steel Pergola

Steel Frame with Powder Coating



Assembly Instructions

Made in China

The owner's manual contains important safety information as well as assembly, use and maintenance instructions. Keep the packaging and bags away from children and dispose of all packaging properly before use. Keep this manual for future reference.



**PLEASE DO NOT
RETURN THIS
PRODUCT
TO THE STORE**

We will be happy to correct any problems that you may have, or answer any of your questions regarding the purchase of this product. Please contact us at our Toll Free customer service number 1-800-599-8898 for any assistance and replacement parts. Thank You.

Dist. by TDC USA, Inc. Fairfield, NJ 07004
©2023 All Rights Reserved.
Made in China
Item 21713
www.tdcusainc.com

⚠ WARNING!

- Keep all children and pets away from assembly area. Children and pets should be supervised when they are in the area of the product construction.
- Some parts may contain sharp edges. When assembling and using this product, basic safety precautions should always be.
- Please read all the instructions and warnings before assembling. In order to make the whole product adjust to the best, please install all the screws on the product and tighten all the screws after adjusting the product which can stand on the floor even. Not intended for commercial use.
- Check all bolts for tightness before use.
- **IMPORTANT** - check and tighten bolts often to keep them secure

• **CHOKING HAZARD** - Small parts. Not suitable for children under 36 months. The product contains small parts, keep children away when assembling.







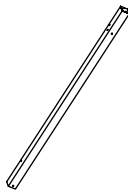
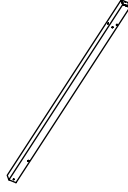
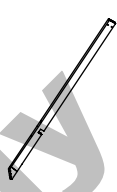

• **ADULT ASSEMBLY REQUIRED.**
Always remove protective material and poly bags and dispose before assembly.

Warnings & Cautions

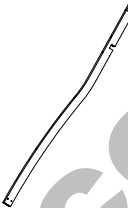
1. Some sections require working overhead and lifting components. Beams can be heavy and awkward to lift into place by yourself.
2. Ask others to lend a hand. We recommend having four people to help in the assembly of your pergola. Having others to help in the building process will result in faster installation.
3. Use appropriate safety measures when working on ladders. Make sure any ladders you're using are sturdy and safe. Follow manufacturer safety instructions when using ladders.
4. Keep a clean, uncluttered work space.
5. Your pergola is susceptible to wind. Make sure the canopy is tied and stakes are hammered down.
6. In the event of adverse weather conditions, it is recommended that the canopy is removed from the frame so that no damage will occur.
7. This product is designed for leisure use only and is not a shelter against adverse weather conditions.
8. DO NOT stand, sit, or store items on top of the pergola
9. DO NOT climb on or hang from any portion of your pergola.
10. Failure to heed these recommendations may result in personal injury or components of the pergola being damaged.
11. At regular intervals, inspect your pergola to make sure that assembly integrity has been maintained.
12. Exercise caution using a lawn mower, edge trimmer or other yard equipment near pergola.

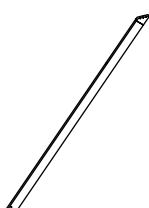
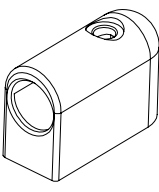
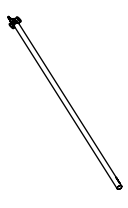
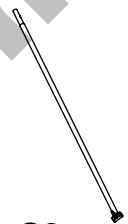
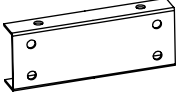
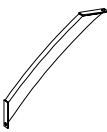
WARNING

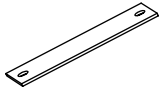
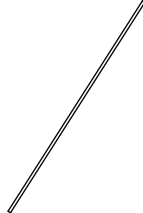
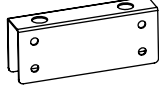
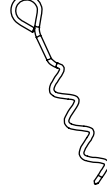
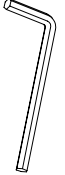
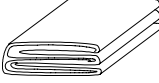
KEEP ALL FLAME AND HEAT SOURCES AWAY FROM THIS TENT FABRIC. This tent is made with fabric that meets CPAI-84 specifications for flame resistance. It is not fire proof. The fabric will burn if left in continuous contact with any flame source.

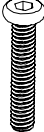
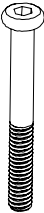
 A1 (x2) Pole	 A2 (x2) Pole	 B1 (x2) Crossbeam	 B2 (x2) Crossbeam	 C (x2) Crossbeam
 D (x2) Crossbeam	 E1 (x5) Canopy Support	 E2 (x5) Canopy Support	 F (x8) Slide Bar Connector	 G1 (x2) Canopy Weight Bar
 G2 (x2) Canopy Weight Bar	 H (x7) Connector	 I (x8) Support	 J (x4) Foot	 K (x4) Cover
 L (x2) Plate	 M (x4) Slide Bar	 N (x7) Crossbeam Connector	 O (x16) Stakes	 P (x1) Hex Key
 Q (x1) Canopy	 AA (x4) M6x10 Bolt	 BB (x70) M6x15 Bolt	 CC (x8) M6x45 Bolt	 DD (x26) M6x65 Bolt

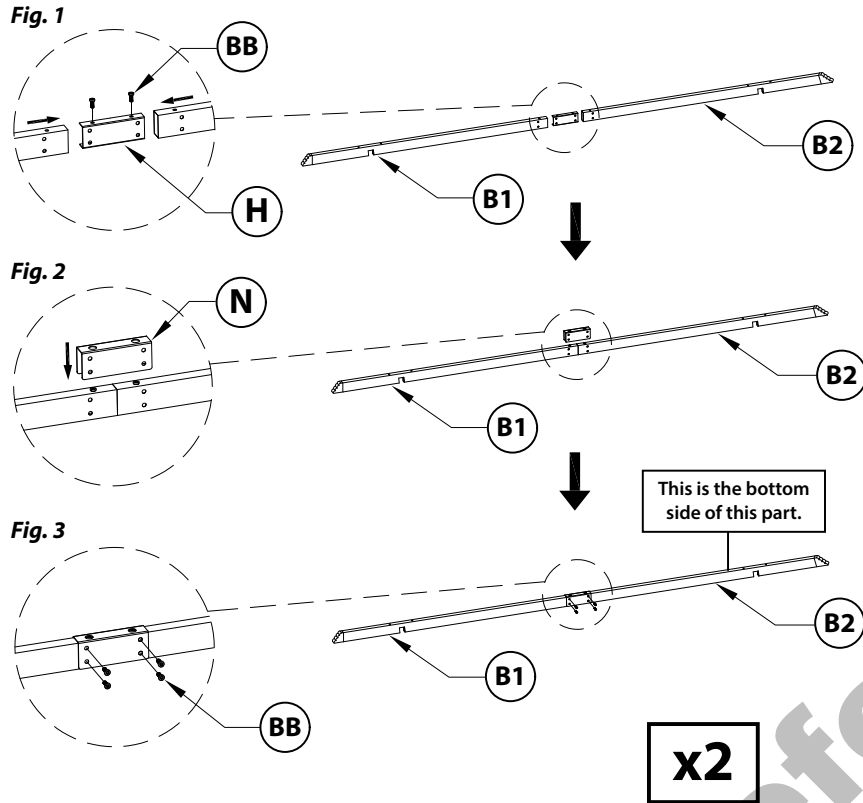

Step 1:

Insert Connector (H) into the open end of Crossbeam (B1), see Fig. 1. Insert one M6x15 Bolt (BB) through the bottom eyelet of Crossbeam (B1), and into the bolt-threading found at the bottom of Connector (H), see Fig. 1. Insert open end of Crossbeam (B2) over opposite end of Connector (H), and use one M6x15 Bolt (BB) to secure these parts together, see Fig. 1.

Place Crossbeam Connector (N) over where Crossbeams (B1 & B2) meet as illustrated here, see Fig. 2.

Insert two M6x15 Bolts (BB) through eyelets on both ends of Crossbeam Connector (N), and into the bolt-threading found on the sides of Crossbeam (B1 & B2) where these parts meet, see Fig. 3. Make sure all bolts are securely tightened. Follow these steps to connect remaining part B1 and part B2 with part H and part N.

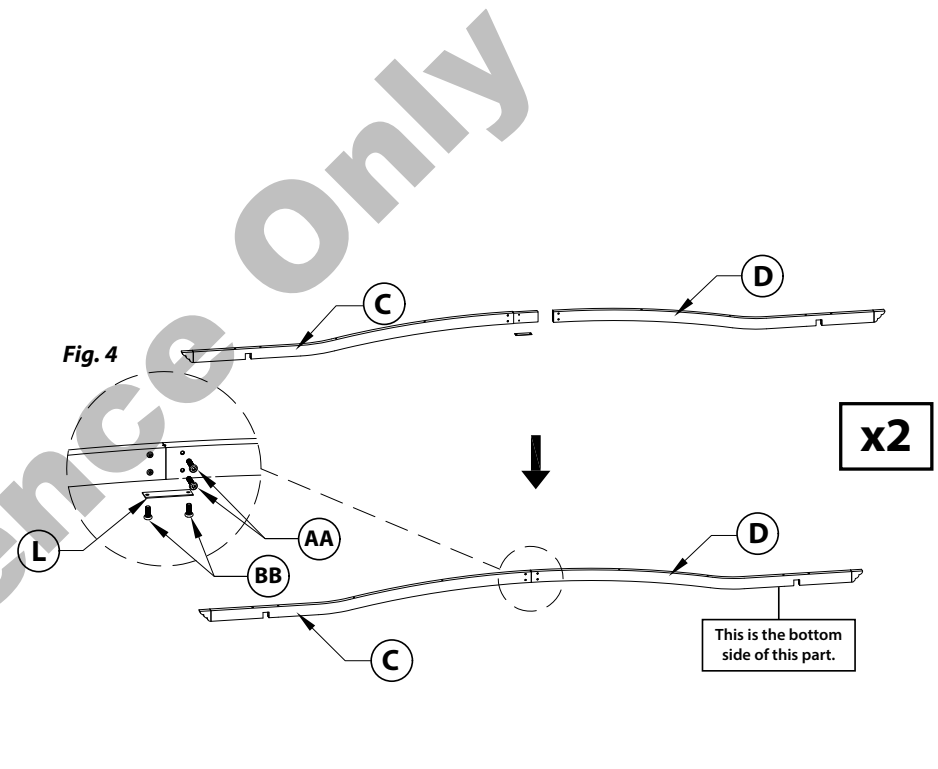

Step 2:

Insert end of Crossbeam (C) with preassembled connector into open end of Crossbeam (D), see Fig. 4. Insert two M6x10 Bolts (AA) through eyelets on the side Crossbeam (D), and into the bolt-threading found on connector at the end of Crossbeam (C).

Insert two M6x15 Bolts (BB) through both ends of Plate (L), and into bolt-threading found on the bottoms of Crossbeams (C & D), see Fig. 4. Make sure all bolts are securely tightened. Follow these steps to connect remaining part C and part D with remaining part L.

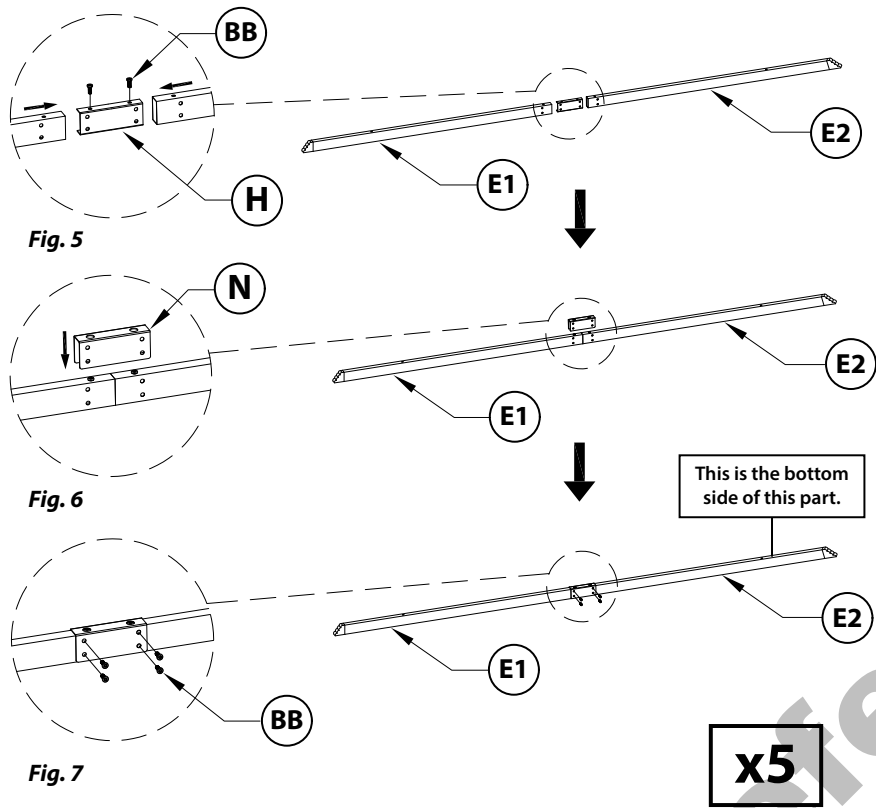

Step 3:

Insert Connector (H) into the open end of Canopy Support (E1), see Fig. 5. Insert one M6x15 Bolt (BB) through the bottom eyelet of Canopy Support (E1), and into the bolt-threading found at the bottom of Connector (H), see Fig. 5. Insert open end of Canopy Support (E2) over opposite end of Connector (H), and use one M6x15 Bolt (BB) to secure these parts together, see Fig. 5.

Place Crossbeam Connector (N) over where Canopy Support (E1 & E2) meet as illustrated here, see Fig. 6.

Insert two M6x15 Bolts (BB) through eyelets on both ends of Crossbeam Connector (N), and into the bolt-threading found on the sides of Canopy Support (E1 & E2) where these parts meet, see Fig. 7. Make sure all bolts are securely tightened. Follow these steps to connect remaining part E1's and part E2's with remaining part H's and part N's.

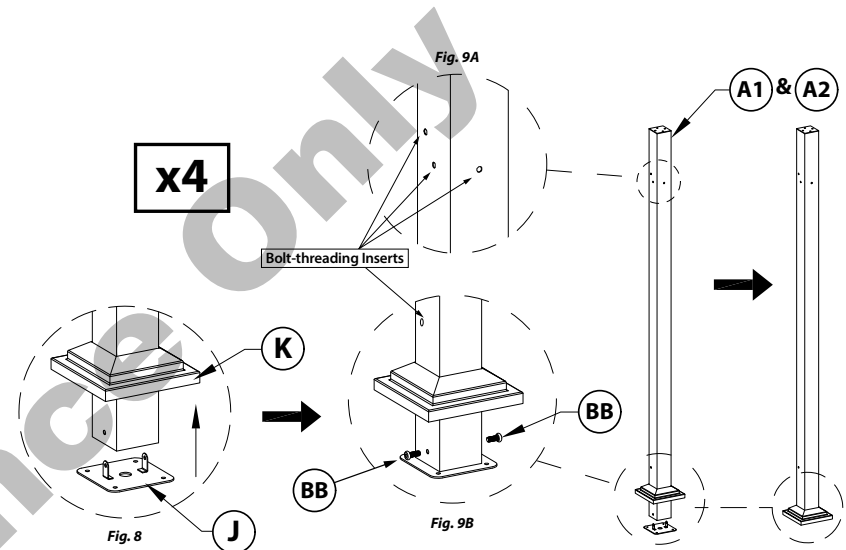

Step 4:

Slide Covers (K) onto Poles (A1 & A2) from the bottom of these parts, see Fig. 8. Insert Foot (J) into the bottom openings of Poles (A1 & A2), and secure these parts together using two M6x15 Bolts (BB), see Fig. 8 & 9B. Slide Cover (K) over Foot (J) when assembly is completed. Follow these steps to connect remaining part A1 and part A2 with remaining part J's and part K's.

Please take note of the bolt-threading inserts found near the top and bottom of both Poles (A1 & A2). Two of the inserts are by one another near the top (Fig. 9A), and one near the bottom on one side of each pole (Fig. 9B). On the adjacent side of each pole, one of the inserts will be found near the top only, see Fig. 9A. It is important to be aware of the placement of these inserts to avoid error during construction.

***Do not tighten bolts down completely during this portion of assembly.**

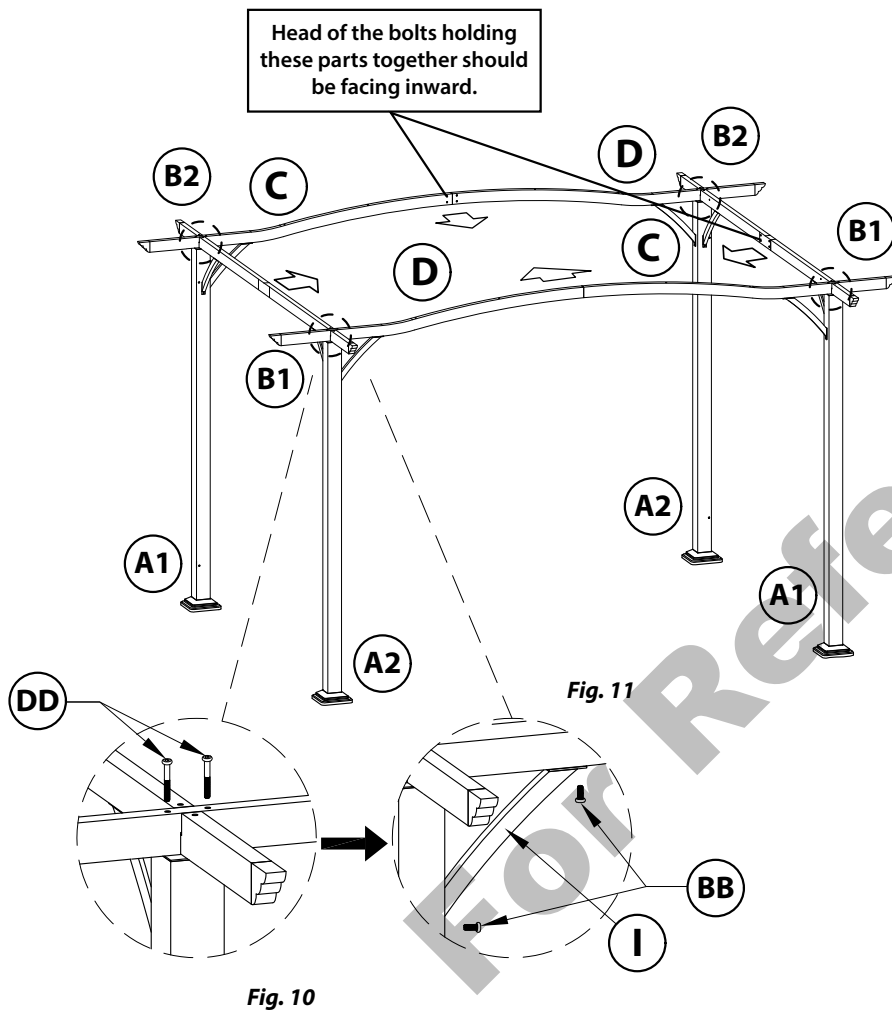

Step 5:

Place assembled Crossbeams (B1 & B2) on top of two standing Poles (A1 & A2). **Please note the correct orientation, and placement of these parts to one another as illustrated on page 10. It is most important to note that the side of each pole with the single, unused bolt-threading insert near the tops will be 'Facing Inward,' see directional arrows on page 10. Not having Poles (A1 & A2) in the correct orientation will require parts be disassembled, and reassembled correctly later during construction of this product.**

Insert two M6x65 Bolts (DD) through eyelets found by notch of Crossbeam (B2), and into the top of Pole (A1), see Fig. 10. Insert two M6x65 Bolts (DD) through eyelets found by notch of Crossbeam (B1), and into the top of Pole (A2). Follow these steps to connect remaining part B1 with part B2 to remaining part A1 and part A2.

Insert one M6x15 Bolt (BB) through one end of Support (I), and into bolt-threading insert found beneath Crossbeams (B2), see Fig. 11. Insert second M6x15 Bolt (BB) through opposite end of Support (I), and into bolt-threading insert found near the top of Pole (A1), see Fig. 11. Follow these steps to connect I to remaining part B2 and part A1.

Insert one M6x15 Bolt (BB) through one end of Support (I), and into bolt-threading insert found beneath Crossbeams (B1). Insert second M6x15 Bolt (BB) through opposite end of Support (I), and into bolt-threading insert found near the top of Pole (A2). Follow these steps to connect part I to remaining part B1 and part A2.

***Do not tighten bolts down completely during this portion of assembly.**

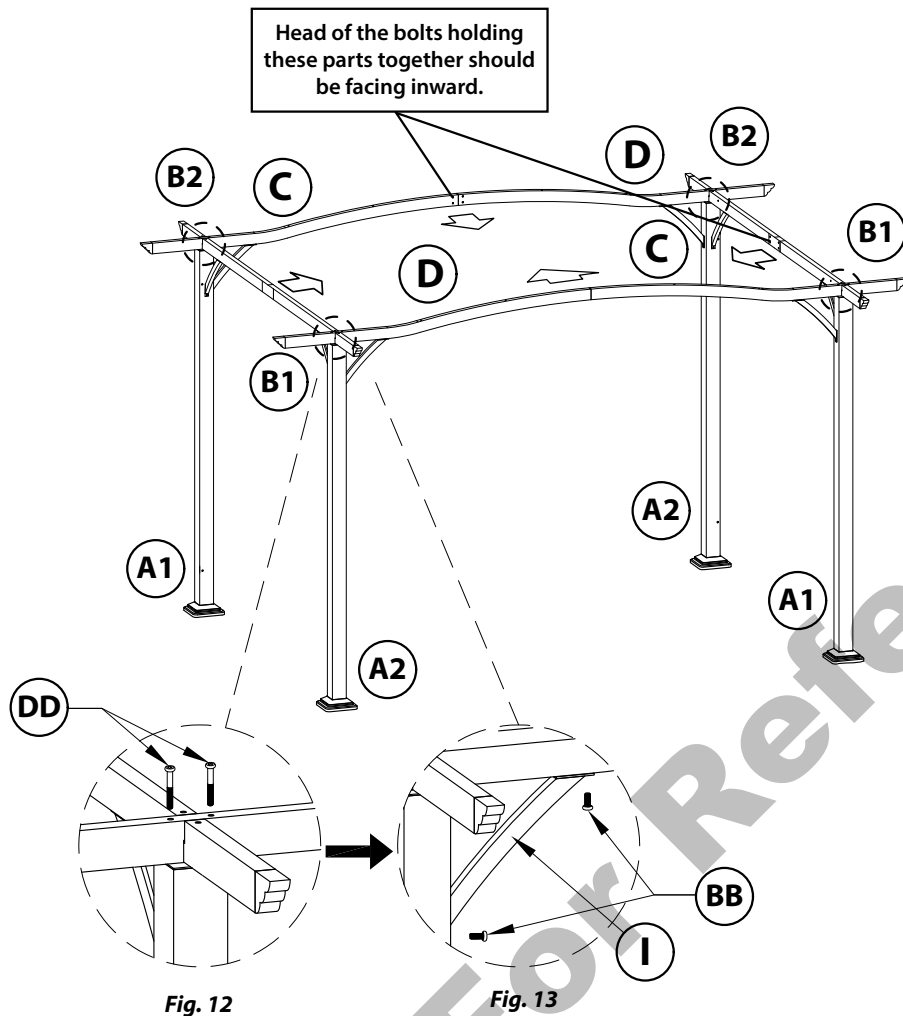

Step 6:

Insert notch found near decorative end of Crossbeam (D) into notch of Crossbeam (B1) that is connected to Pole (A2). Insert two M6x65 Bolts (DD) through eyelets of Crossbeam (D), and into the top of Pole (A2), see Fig. 12. Follow these steps to connect remaining part D to second part A2.

Insert notch found near decorative end of Crossbeam (C) into notch of Crossbeam (B2) that is connected to Pole (A1). Insert two M6x65 Bolts (DD) through eyelets of Crossbeam (C), and into the top of Pole (A1). Follow these steps to connect remaining part C to second part A1.

Insert one M6x15 Bolt (BB) through one end of Support (I), and into bolt-threading insert found beneath Crossbeams (D), see Fig. 13. Insert second M6x15 Bolt (BB) through opposite end of Support (I), and into bolt-threading insert found near the top of Pole (A2), see Fig. 13. Follow these steps to connect part I to remaining part D and part A2.

Insert one M6x15 Bolt (BB) through one end of Support (I), and into bolt-threading insert found beneath Crossbeams (C). Insert second M6x15 Bolt (BB) through opposite end of Support (I), and into bolt-threading insert found near the top of Pole (A1). Follow these steps to connect part I to remaining part C and part A1.

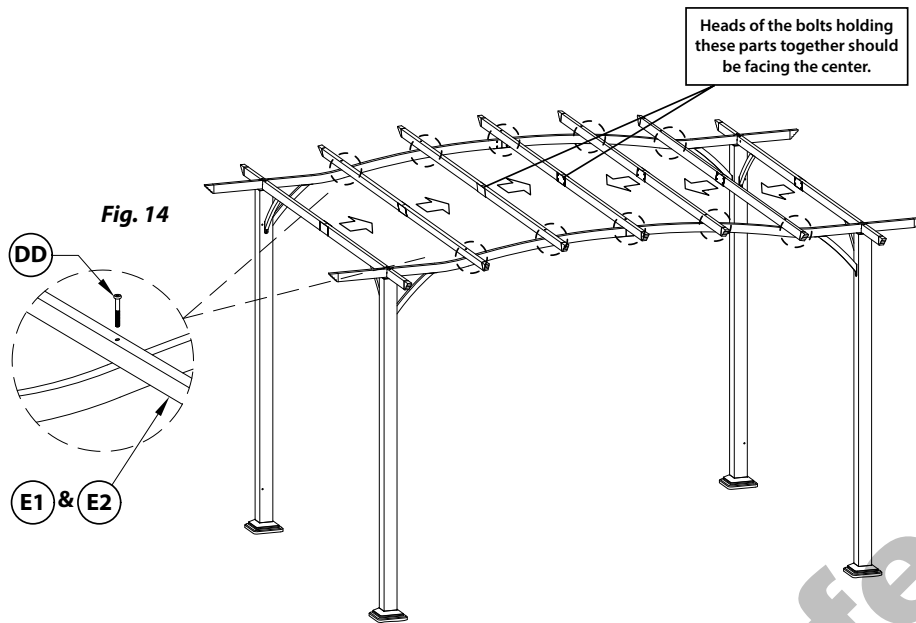

Step 7:

Place all five assembled Canopy Supports (E1 & E2) across the frame, where they are resting on top of Crossbeams (C & D). For a consistent look, place Canopy Supports (E1 & E2) on top so that their placement matches what is illustrated here, i.e. the heads to the bolts holding part E1 and part E2 together are facing towards the center. Insert one M6x65 Bolt (DD) through each end of assembled Canopy Supports (E1 & E2), and into the tops of Crossbeams (C & D), see Fig. 14.

***Parts G1 and G2 are not stiff when connected, they are meant be flexible.**

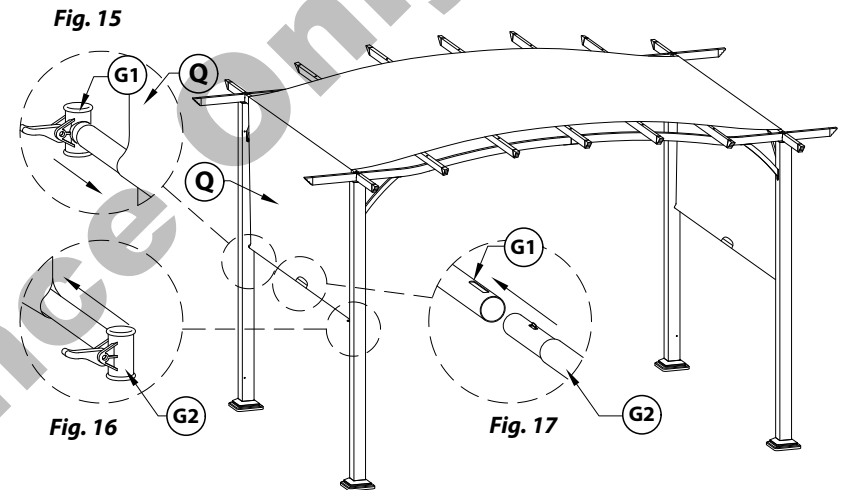

Step 8:

Place Canopy (Q) over Canopy Supports (E1 & E2). Please note that the canopy tags should be facing inward once this step is complete.

Insert Canopy Weight Bar (G1) through the sleeve of Canopy (Q), closes to Pole (A1), see Fig. 15. Insert Canopy Weight Bar (G2) through opposite side of sleeve found at the other end of Canopy (Q), closes to Pole (A2), see Fig. 16. Insert end of Canopy Weight Bar (G2) into the open end of Canopy Weight Bar (G1), so that they lock in place, see Fig. 17. Please note that the latches to these two parts should be facing outward.

These parts must be in this exact placement for the latches of the Canopy Weight Bars (G1 & G2) to lock when in the down position and unlock when in the up position. In addition, the Slide Bars (M) will need to be inserted from the bottom of these latches; please see Step 9 for more details.

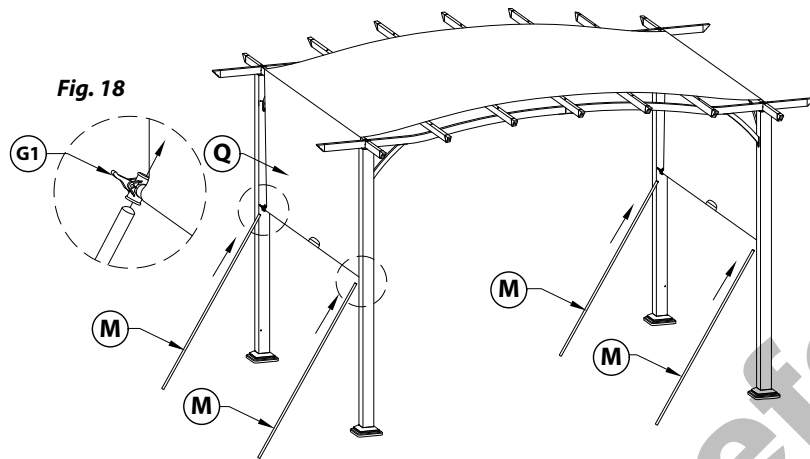

Step 9:

Insert the top Slide Bars (M), where their eyelet, through latches at the ends of Canopy Weight Bars (G1 & G2), see Fig. 18. Part M must be inserted through the bottom of these latches while the latch is in the unlocked position (the latch lever is up) for it to go through easily. If you're not able to insert part M from the bottom-up, check that you have the Canopy Weight Bars (G1 & G2) in the correct placement; please see Step 8 for more details.

***Complete assembly by securely tightening all bolts.**

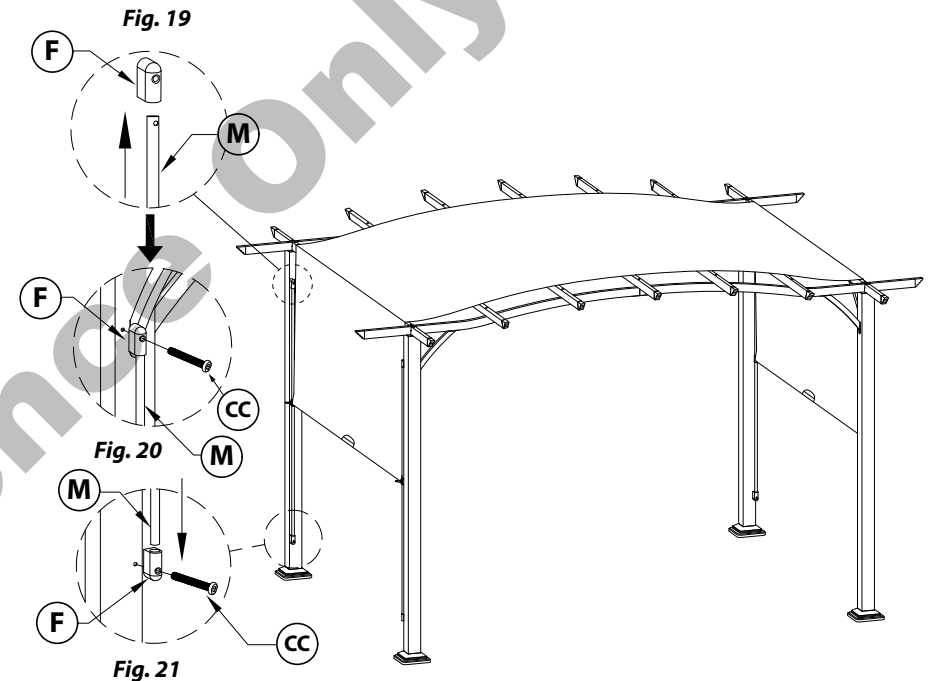

Step 10:

Insert top ends of Slide Bars (M) with eyelets into Slider Bar Connectors (F), see Fig. 19. Insert one M6x45 Bolt (CC) through Slider Bar Connectors (F), through Slide Bars (M), and into bolt-threading inserts found near the tops of Poles (A1 & A2), see Fig. 20.

Insert one Slider Bar Connector (F) at the opposite ends of Slide Bars (M). Insert one M6x45 Bolt (CC) through Slider Bar Connectors (F), and into bolt-threading inserts found near the bottoms of Poles (A1 & A2), see Fig. 21. **When finished, only the top ends of Slide Bars (M) will be bolted down to Poles (A1 & A2), while the bottom ends will rest inside of Slide Bar Connectors (F), on top of the M6x45 Bolts (CC).**

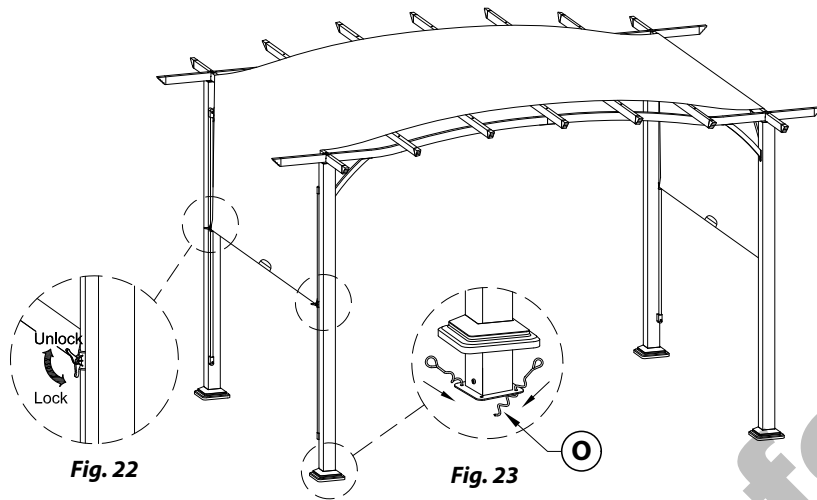

Step 11:

To lock the Canopy (Q) in place, push the latches down on the ends of the Canopy Weight Bars (G1 & G2), see Fig. 22. Lift up on latches to unlock them on both sides of pergola when adjusting the height of the canopy.

Lift Covers (K) up, and screw four Stakes (O) through designated eyelets of Feet (J), and into the ground for extra stability, see Fig. 23.

For Reference Only

LIMITED WARRANTY

Please contact our service hotline by phone, email, or fax when needing assistance with assembly or with faulty parts. This allows us to provide support in the event of possible operator errors.

All furniture manufactured and sold by TDC USA, Inc. is warranted to the original purchaser against defects in workmanship and materials. If a product manufactured by TDC fails during the first year from date of purchase under the terms of our limited warranty, TDC will replace the item at no charge. After one year, it will be the original purchaser's responsibility to pay for freight and packing. TDC reserves the right, in the case of discontinued or out of production models, to replace with an item of similar quality. (Glass breakage is not warranted.)

NOTE: You must retain original receipt to obtain warranty!

FRAMES:

Frames are warranted against defects in materials and workmanship from the date of original purchase. Damage to frames or welds due to commercial use, improper assembly, exposure to water and sub-freezing temperatures, and/or abuse are not covered.

FABRIC:

Fabric on cushions, slings, and umbrellas is warranted against separation at the seams. Fading, mildew, and/or discoloration due to exposure to elements, chemicals, and spills are not covered.

POWDER COAT AND/OR PAINT:

The finish is warranted against blistering, peeling, or cracking. Fading resulting from exposure to the elements, chemicals, and spills are not covered. Scratches and chips due to normal wear and use are not covered.

FREIGHT & PACKING:

TDC will be responsible for shipping, handling, and packaging charges for all valid warranty claims.

CARE & MAINTENANCE:

Be careful to never allow water build up in frames as this will cause corrosion and freeze damage in cold climates. Wash all frames with a solution of mild soap and water. Rinse with clean water and dry with a soft absorbent cloth towel. Frames can be treated with a liquid wax for maximum protection against UV rays and/or salty damp air. If your set includes cushions, slings, and/or an umbrella, they may be cleaned by hand with a solution of soap and water with a clean water rinse.

LIMITED WARRANTY EXCLUSIONS:

- Damage caused by acts of nature
- Wind damage
- Failure caused by unreasonable, unanticipated, or abusive use
- Failure caused by a lack of reasonable and necessary care and maintenance
- Normal fade of fabrics, upholstery, or woven materials
- Glass table tops
- Bursting or cracking of tubing due to exposure to water and freezing temperatures
- Changes in wood color due to the natural aging of the wood

A sales receipt must be provided to validate the 1-Year Limited Warranty.

Customer Service:

Monday - Friday • 9:00 am - 5:00 pm

Phone: 800-599-8898

Email: support@tdcusainc.com

TDC USA, Inc.

5 Industrial Rd, STE 1

Fairfield, NJ 07004-3017

Steel Pergola

Steel Frame with Powder Coating

Dist. by TDC USA, Inc. Fairfield, NJ 07004
©2023 All Rights Reserved. Made in China.
Item #21713

Questions and Comments

1-800-599-8898 (9 am - 5 pm EST)

www.tdcusainc.com