

LAND ROVER RANGE ROVER VELAR

BATTERY POWERED ELECTRIC RIDE-ON

[BATTERY IS REPLACEABLE]

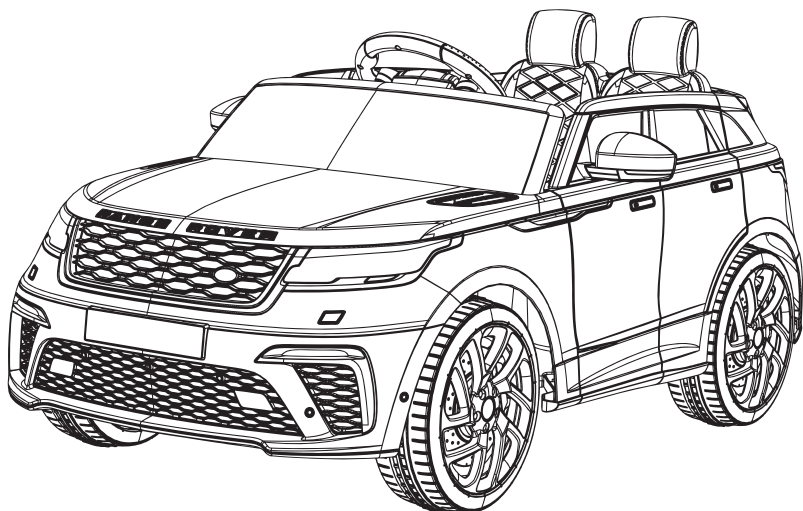

OWNER'S MANUAL

WITH ASSEMBLY INSTRUCTIONS

MADE IN CHINA.

The owner's manual contains important safety information as well as assembly, use and maintenance instructions. The Ride-on Car must be assembled by an adult who has read and understands the instructions in this manual. Keep the packaging and bags away from children and dispose of all packaging properly before use. Keep this manual for future reference.



**PLEASE DO NOT
RETURN THIS
PRODUCT
TO THE STORE**

We will be happy to correct any problems that you may have, or answer any of your questions regarding the purchase of this product. Please contact us at our Toll Free customer service number 1-800-599-8898 for any assistance and replacement parts. Thank You.

Dist. by TDC USA, Inc. Fairfield, NJ 07004

©2022 All Rights Reserved.

Made in China.

Item 61129

www.tdcusainc.com

1 YEAR LIMITED WARRANTY SIX MONTH LIMITED WARRANTY ON BATTERY

6-months warranty applies only to the 12-volt battery which is included by TDC USA Inc. with the vehicle when it was originally purchased. This warranty covers normal use and does not cover the vehicle or battery if damaged by unreasonable use, neglect, abuse, accident, misuse, improper service or other causes not arising out of defects in material or workmanship. Evidence of any attempt at consumer repair will void this warranty.

Warranty services are provided by TDC USA Inc. If a hardware defect arises and a valid claim is received during the warranty period, TDC USA Inc. will repair the hardware defect by using new or refurbished parts that are equivalent to new in performance and reliability. This warranty is for 1 replacement only of like-items and does not cover items out of production if the product is no longer made or stocked. This warranty is not assignable or transferable. This warranty covers factory defects only. This warranty will not cover labor, return shipping or the shipping expense to you. The warranty does not cover misuse or broken parts caused by the user or by any other event. If we verify a parts defect, we will repair or replace the part, yet you must pay for our labor to do so at our then current rates (if you do not re-install the part yourself). TDC USA INC. will not be responsible for shipping charges on received or refused packages, part returns, or scooter returns. In the event of a verified warranty claim, we will reimburse you for shipping and we will repair or replace the defective part. However, you must arrange and pay for shipping and you bear the risk of loss and damage for the scooter or part being shipped back to us.

CONDITIONS OF WARRANTY:

The user assumes all risk of personal injuries, damage to, or failure of the Vehicle and any other losses if the Vehicle is altered in any way or if the Vehicle is used for stunt riding, ramp jumping, aerobatics or similar activities, or is towed by another person or vehicle.

THIS WARRANTY DOES NOT COVER ANY DAMAGE DUE TO THE FOLLOWING:

1. Transportation
2. Storage
3. Improper use
4. Failure to follow the product instructions or perform any preventive maintenance
5. Modifications
6. Unauthorized repair
7. Normal wear and tear
8. External causes such as accidents, abuse, or other actions or events beyond our reasonable control
9. Used as a rental
10. Weather related water damage is determined
11. Minor surface blemishes, rips, tears, or other cosmetic damages due to normal use, or other intentional or unintentional damage to the product.
12. Any damage which results from aging, such as fading of paint, deterioration of plated surfaces, deterioration of rubber or plastics, or rusting.

DO NOT DISASSEMBLE THE PRODUCT.

Doing so will void this warranty. Only TDC USA Inc. is the authorized service center who should perform service on this product.



WARNING: Changes or modifications to this unit not expressly approved by the party responsible for compliance could void the user's authority to operate the equipment.

OWNER'S WARRANTY RESPONSIBILITIES:

As the device's owner, you are responsible for the performance of the required maintenance. You may be denied a warranty claim solely because of your failure to ensure the performance of all scheduled maintenance. As the owner, you should be aware that you may be denied your warranty coverage if your device or a part has failed due to abuse, neglect, improper maintenance, or unapproved modifications. For any issue regarding your Ride-On, call toll free 1-(888) 599-8898, or email support@tdcusa.com

- This ride-on car will provide your child with many miles of riding of enjoyment. To help assure you and your rider a safe ride we ask you to please read this manual carefully, and keep it for future reference.
- Follow the recommendations in this manual, they are designed to improve the safety and operation of your ride-on car and it's rider.



WARNING!

- **CHOKING HAZARD** - Small parts. Not suitable for children under 36 months. The product contains small parts, keep children away when assembling.
- **ADULT ASSEMBLY REQUIRED.** Always remove protective material and poly bags and dispose before assembly.

• ASSEMBLY TOOLS REQUIRED:



Screwdriver
(not included)

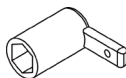

Spanner
(included)



Approximate
Assembly Time:
40 Minutes

Specifications

Age	3+ years
Weight Capacity	Max 66.1 lbs (30 Kg)
Speed	Up to 3.1 MPH
Overall Dimensions	42.52"x24.02"x19.69"
Charge Time	8-12 hours, 20 hour limit
Battery	DC 12V 4AH*1
Charger	Input: 100-240V, 50-60Hz 0.2A - Output: 12V 1000mA

SAFETY

THE FOLLOWING SAFETY HAZARDS MAY RESULT IN SERIOUS INJURY OR DEATH:

- This product contains small parts. Keep children away during assembly. Make sure to remove all packaging material and parts from underneath the vehicle body.
- Never open the battery. Batteries contain lead and lead compounds (acids) that are toxic and corrosive, and known to the state of California to cause cancer and reproductive harm.
- Limbs, hair, and clothing can get caught in moving parts. Always wear shoes, keep limbs away from moving parts, and do not wear loose clothing while operating this vehicle.
- This vehicle does not have brakes or braking capability. Do not leave a child unattended during operation. Do not use this in a location that may require braking capability, as this could result in loss of control, which may cause serious injury or death.
- Use of this vehicle in unsafe conditions such as snow, rain, loose dirt, mud, sand, or gravel may result in an unexpected accident such as tipping over, and could damage the electrical system or battery.
- Do not operate this vehicle in an unsafe manner. Examples include but are not limited to:
 - Pulling the vehicle with another vehicle or similar device
 - Allowing more than one rider
 - Pushing the user
 - Traveling at an unsafe speed

BATTERY WARNINGS

NOT FOLLOWING SAFETY GUIDELINES MAY RESULT IN SERIOUS INJURY OR DEATH:

- Use of a battery charger other than the supplied 12V rechargeable battery and charger may cause a fire or explosion. Only use the supplied battery and charger.
- Use of the 12V rechargeable battery and charger for any other product may result in overheating, fire, or explosion. Never use the supplied rechargeable battery and charger with another product.
- Explosive gases are created during charging. Charge the battery in a well-ventilated area. Do not charge the battery near heat or flammable materials.
- Contact between the positive and negative terminals may result in fire or explosion. Avoid direct contact between the terminals. Picking up the battery by the wires or charger can cause damage to the battery and may result in a fire. Always pick up the battery by its case or handles. The battery is replaceable.
- Liquids on the battery may cause fire or electric shock. Always keep all liquids away from the battery and keep the battery dry. Contact or exposure to battery leakage (lead acid) may cause serious injury. If contact or exposure occurs immediately call your physician. If the chemical is on the skin or in the eyes, flush with cool water for 15 minutes. If the chemical was swallowed, immediately give the person water or milk. Do not give water or milk if the patient is vomiting or has a decreased level of alertness. Do not induce vomiting.
- Battery posts, terminals, and related accessories contain lead and lead compounds (acid) - chemicals known to the state of California to cause cancer, reproductive harm, and are toxic and corrosive. Never open the battery.
- Tampering or modifying the electric circuit system may cause a shock, fire or explosion and permanently damage the system. Exposed wiring and circuitry in the charger may cause electric shock. Always keep the charger housing closed.

RULES FOR SAFE RIDING

- Keep children within safe riding areas: never use in roadway, near motor vehicles, on lawn space, on or near steep inclines or steps, swimming pools or other bodies of water.
- Use the toy only on flat surfaces. Such as inside your house, garden or playground.
- Never use in the dark. A child could encounter unexpected obstacles and have an accident. Operate the vehicle only in the daytime or a well-lit area.
- It is prohibited to change the circuit or add other electric parts
- Inspect wires and connections of the vehicle periodically.
- Do not let any child touch the wheels or be near them when the car is moving.
- This vehicle has adjustable play seat belts. Please instruct children how to tie the safety belt before using, guarantee the security.





WARNING!

PREVENT INJURIES AND DEATHS:

- NEVER LEAVE CHILD UNATTENDED. DIRECT ADULT SUPERVISION IS REQUIRED. Always keep child in view when child is in vehicle.
- This toy should be used with caution since skill is required to avoid falls or collisions causing injury to the user or third parties.
- Protective equipment should be worn.
- Never use in roadways, near cars, on or near steep inclines or steps, swimming pools or other bodies of water.
- Always wear shoes.
- Always sit on the seat.
- Not to be used in traffic.
- This toy is unsuitable for children under 3 years old due to its maximum speed; Maximum user weight is 66 lbs.
- This toy has no brake.
- Keep your hands, hair, and cloths away from moving parts.
- Only one rider is allowed on the vehicle at a time.
- Only drive on level ground.
- Do not drive the vehicle into loose dirt, mud, sand, fine gravel, or on wet surfaces.
- Do not drive the vehicle on streets or near cars.

PART	PART NAME	QUANTITY (PCS)
1	CAR BODY	1
2	MOTOR	2
3	WHEEL	4
4	REAR WHEEL AXLE	1
5	STEERING WHEEL	1
6	REAR VIEW MIRROR	2
7	WINDSHIELD	1
8	SEAT	1
9	ST4*14 MM SCREW	1

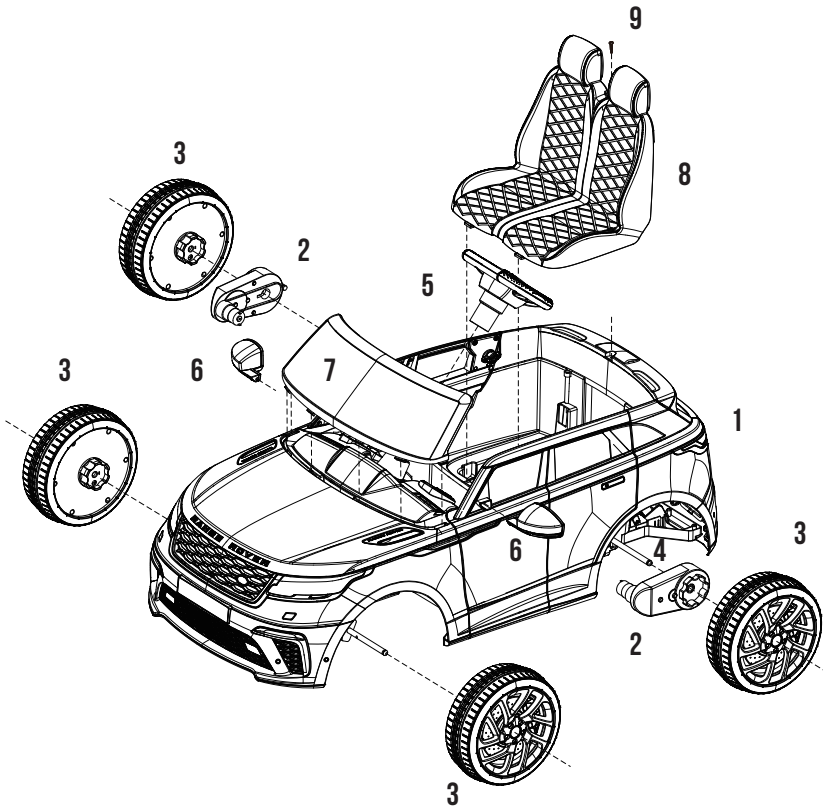

Note: Some parts shown are assembled on both sides of vehicle

ATTENTION:

PRIOR TO ASSEMBLY, PLEASE CHECK ALL PARTS ARE INCLUDED IN THE BOX WITH THE PART LIST ON PAGE 8. DO NOT ASSEMBLE THE CAR IF MISSING PARTS ARE FOUND. CONTACT CUSTOMER SUPPORT IMMEDIATELY BEFORE ASSEMBLY.

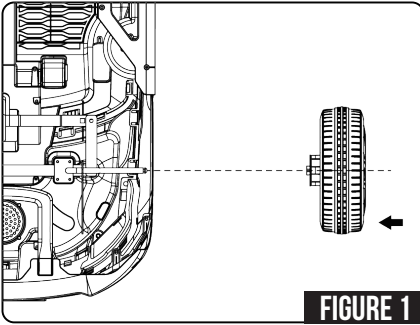

FIGURE 1

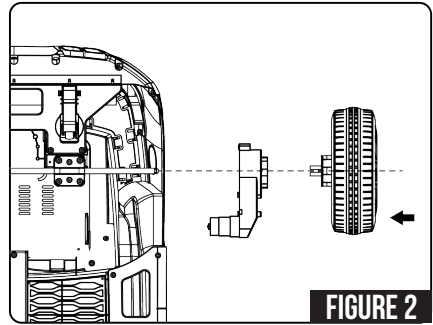

FIGURE 2

PRIOR TO INSTALL:

Turn the vehicle body upside down.
To prevent any scratches, place the vehicle on top of a soft surface before installing.

INSTALLING REAR WHEELS:

For the rear wheels, first install the motor onto the rear axle then follow by the wheel as depict in figure 2. The wheels have a snap on feature that does not require any hardware. Make sure the wheel is properly locked onto the rear axle completely. There should be a clip sound when it is performed properly. Repeat on the other side.

INSTALLING FRONT WHEELS:

For the front wheels, install the wheel onto the rear axle as depict in figure 1. Make sure the wheel is properly locked onto the rear axle completely. There should be a click sound when locked properly. Repeat on the other side.

CONNECT THE POWER SUPPLY

- Connect the red power terminal with the red terminal on the main line.

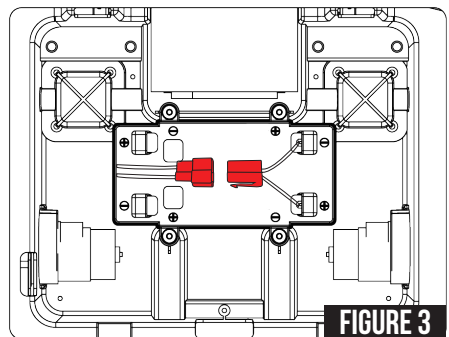
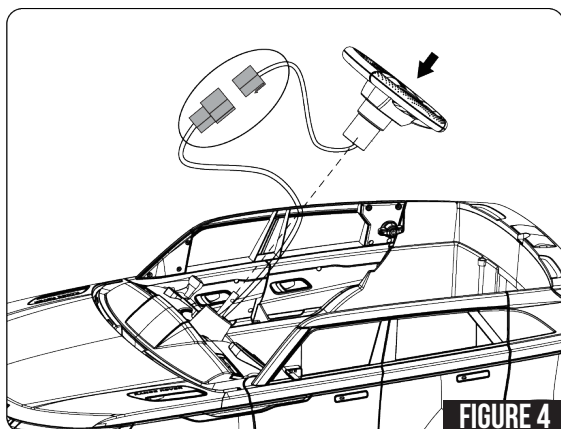
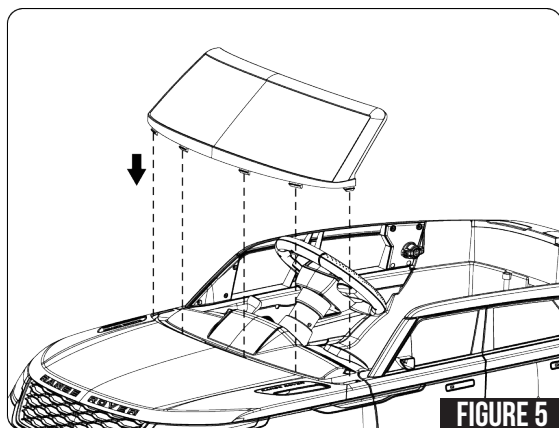

FIGURE 3



STEERING WHEEL INSTALLATION

- Connect the lines, insert the steering wheel in the correct direction. Use finger to press the two steel round balls, push the steering wheel until the ball locks in the two holes.



INSTALL THE WINDSHIELD

- Press the wind shield into the car body, make sure all position is properly settled into the dashboard.

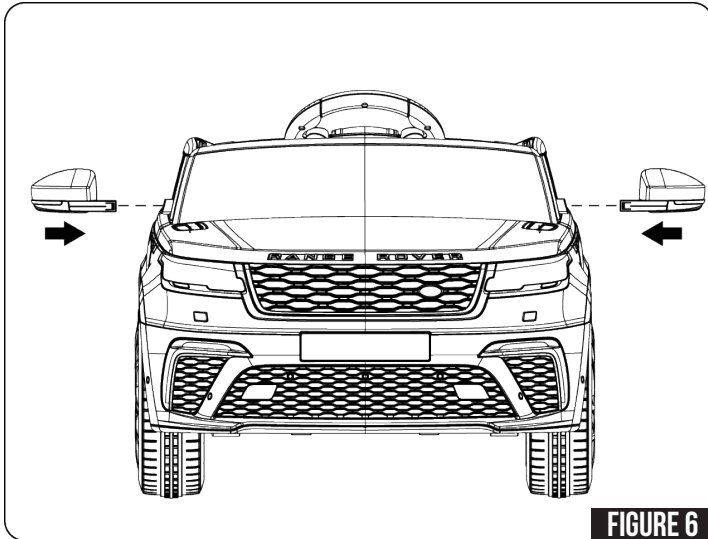
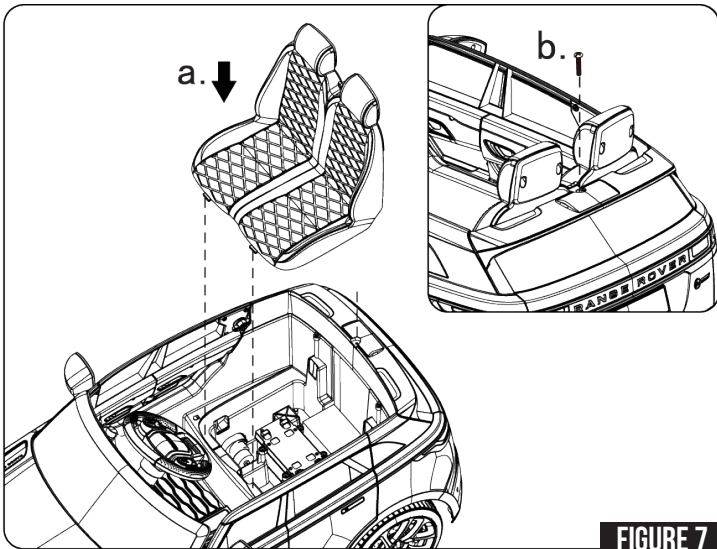

FIGURE 6

INSTALL THE MIRRORS

- Insert the side mirrors onto the two sides of the car body as depict in Figure 6.

**FIGURE 7**

INSTALL THE SEAT

- Tilt the seat at a 45 degree angle and guide the seat onto the vehicle body by inserting the bottom tabs on the seat into the vehicle body. Secure the seat onto the vehicle body by using screw 4x14 mm (Part 9) as depicted in Figure 7.

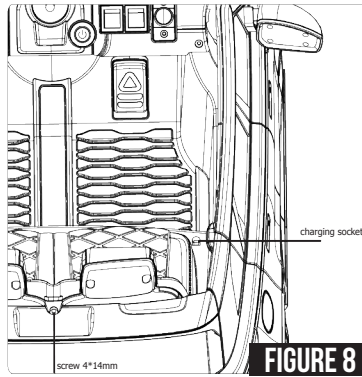

USE OPERATION (ENSURE THE POWER SWITCH HAS BEEN TURNED ON)

To turn on the car, press the power switch as depicted in Figure 8.

To turn on the lights, locate the light switch button on Figure 8 and press the bottom.

To move forward, push the shift switch to the forward position and step down on the foot pedal.

To move backwards, push the shift switch to the reverser position and step down on the foot pedal.

To stop the vehicle, release the foot pedal and the car will slowly come to a stop.

To turn off the car, press the power switch again to shut off.

To charge the car, located the charging socket as indicated in Figure 8 and connect the charger into place.

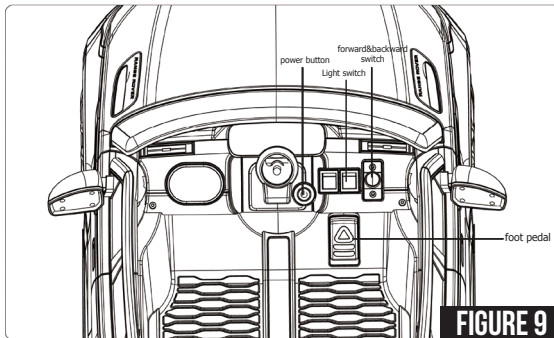

IMPORTANT!

Always stop vehicle when changing forward to reverse direction to avoid damage to the gear box and motor.

ONLY AN ADULT CAN CHARGE AND RECHARGE THE BATTERY!**WARNING!****PREVENT FIRE AND ELECTRIC SHOCK:**

- Use the only rechargeable battery and charger supplied with your vehicle. NEVER substitute the battery or the charger with another brand. Using another battery or charger may cause a fire or explosion.
- Do not use the battery or charger for any other product. Overheating, fire or explosion could occur.
- NEVER modify the electric system. Tampering with the electric system may cause a shock, fire or explosion or may permanently damage system.
- Do not allow direct contact between battery terminals. Fire or explosion can occur.
- Do not allow any type of liquid on the battery or its components.
- Explosive gases are created during charging. Do not charge near heat or flammable materials. Charge the battery in a well-ventilated area ONLY.
- NEVER pick up the battery by the wires or charger. Damage can occur to the battery and may cause a fire. Pick up the battery by the case ONLY.
- Charge the battery in a dry area ONLY.
- Remove highlighted section. WASH HANDS AFTER HANDLING.
- Do not open the battery. Battery contains lead acid and other materials that are toxic and corrosive.
- Do not open the charger. Exposed wiring and circuitry inside case may cause electric shock.
- Only adults may handle or change the battery. NEVER allow child to handle or charge the battery.
- Battery is heavy and contains lead acid (electrolyte).
- Do not drop battery. Permanent damage to the battery could occur or cause serious injury.
- Before charging the battery, check for wear or damage to the battery, charger, its supply cord and the connectors. DO NOT charge the battery if any damage to parts has occurred.
- Do not allow the battery to drain completely. Recharge the battery after each use or once a month if not used regularly.
- Do not charge battery upside down.
- Always secure the battery with the bracket. Battery can fall out and injure a child if vehicle tips over.
- A recommendation for adult supervision of young children.
- The toy should be used with caution since skill is required to avoid falls or collisions causing injury to the user or third parties.

- **THE CHARGING INPUT SOCKET IS BELOW THE SEAT.**
- **THE POWER SWITCH MUST BE TURNED IN OFF POSITION WHEN CHARGING.**
- **WHEN THE VEHICLE BEGINS TO RUN SLOWLY, RECHARGE THE BATTERY.**
- **AFTER EACH USE OR ONCE OF MONTH MINIMUM RECHARGE TIME AS 8 TO 12 HOURS, NO MORE THAN 20 HOURS.**

⚠ WARNING!

Please plug wall charger directly into a wall outlet. Do not use an extension cord

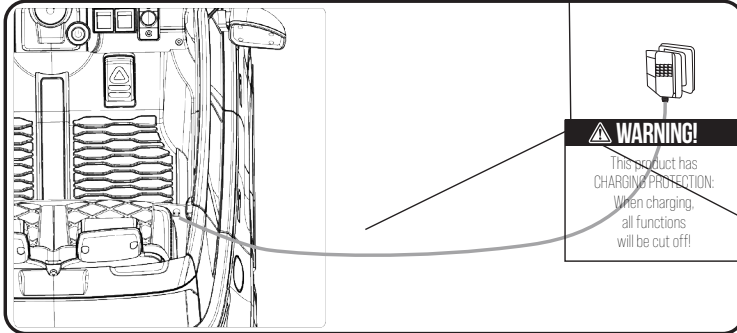

- When charging, turn off the power switch. After first use, recommend to charge 16 hours but not more than 20 hours.
- When the vehicle speed slows down obviously, indicating the battery is low, please charge. After use, please charge 8 to 12 hours, not exceeding 20 hours.

BATTERY DISPOSAL

- Your sealed lead-acid battery must be recycled or disposed of in an environmentally sound matter.
- Do not dispose of your lead-acid battery in a fire. The battery may explode or leak.
- Do not dispose of a lead-acid battery in your regular household trash. The incineration, land filling or mixing of sealed lead-acid batteries with household trash is prohibited by law.
- Return an exhausted battery to your local approved lead-acid battery recycle, such as a local seller of automotive batteries.
- Contact your local waste management officials for other information regarding the environmentally sound recycling and disposal of lead-acid batteries.
- The battery must be charged only by an adult. Please charge the product before using!
- The toy should not be connected to excessive powers (more than the quantity specified herein), and it should not be operated during the charging process.
- Any rechargeable battery must only be charged under an adult's supervision.
- Battery charger shall regularly check the wires, plugs, casing and other parts for damage and found damage should stop using and restored.
- Open the battery cover on the remote control, and put two pieces of batteries, paying attention to batteries' polarity. Replace the battery cover and lock with screws. (Please replace the battery according to the above steps and should be done by an adult.)
- All batteries should be inserted with the correct polarity.
- Non-rechargeable battery should not be charged, please remove any running-off battery from toy.
- Do not use and new batteries together, or mix different types of batteries.
- The battery charger used with the toy are to be regularly examined for damage to the cord, plug, enclosure and other parts, and in the event of such damage, they must not be used until that damage has been repaired.

Troubleshooting Table | 17

PROBLEM	POSSIBLE CAUSE	POSSIBLE CAUSE
	Battery low on power	After each use or once a month at a minimum, charge the battery for 8-12 hours. Do not leave the battery on the charger for more than 20 hours.
	Thermal fuse has tripped	The vehicle is equipped with a self-resetting fuse. When the vehicle is overloaded or operated incorrectly, the resetting fuse will be cut off for 5-20 seconds before becoming operational again. The self-resetting fuse is under the set.
Vehicle Does Not Run	Battery connector or wires are loose	Make sure the battery connectors are firmly plugged into each other.
	Battery is dead	Replace battery. Please call us at 1-800-599-8898 for battery replacement.
	Electrical system is damaged	Check to see if water may have corroded the system. Loose dirt, gravel or sand might have jammed the switch.
	Motor is damaged	Please call us at 1-800-599-8898.
	Wheel nuts are loose	If the nuts are not tight, the wheels will not engage the forward gears. Tighten the nut with the nut wrench.
	Battery connector or adapter connector is loose	Make sure the battery connector and adapter connector are firmly plugged together.
Battery Will Not Recharge	Charger is not plugged in	Make sure the charger is plugged into the wall outlet and the power flow to the outlet is one.
	Charger is not working	Is the charger warm while charging? If not, the charger may be broken and may need to be replaced.
The Vehicle Does Not Run Very Long	Battery may be undercharge	You may not be charging the battery long enough. After each use, or once a month minimum, charge the battery to 8 to 12 hours. Do not leave the battery on the charger for more than 20 hours.
	Battery is old.	The battery will eventually lose the ability to hold a charge. Depending on the amount of use, and varying conditions, the battery should operate for one to three years. Replace the battery with a new one.
Battery Buzzes or Gurgles When Charging	This is normal and not a cause for concern.	
Charger Feels Warm When Recharging Battery	This is normal and not a cause for concern.	

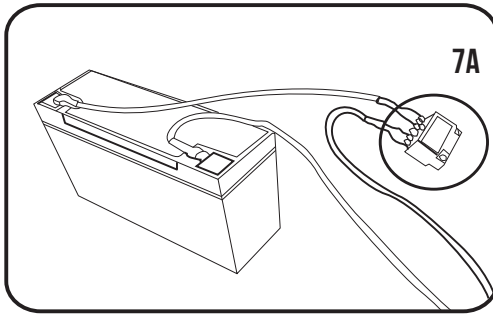

TO AVOID THE FUSE CUT OFF THE POWER, FOLLOW THESE GUIDELINES:

- Max: 30kgs, overload is forbidden.
- Do not drag any items behind this products.
- Do not allow water or other liquids dip the electrical parts.
- Do not change the line system by yourself.

MAINTAINING THE VEHICLE

- It is the parents responsibility to check main parts of the toy before using. Must regularly examine for potential hazard, such as the battery, charge, cable or cord, plug, screws are fastening enclosure of other parts and that in the event of such damage, the toy must not be used until the damage has been properly removed.
- Make sure the plastic parts of the vehicle are not cracked or broken.
- Occasionally use a lightweight oil to lubricate moving parts such as wheels.
- Park the vehicle indoors or cover it with a tarp to protect it from wet weather.
- Keep the vehicle away from sources of heat, such as stoves and heaters. Plastic may melt.
- Recharge the battery after each use. Only an adult can handle the battery. Recharge the battery at least once a month when the vehicle is not being used.
- Do not wash the vehicle with a hose. Do not wash the vehicle with soap and water. Do not drive the vehicle in rainy or snowy weather. Water will damage the motor, electric system and battery.
- Clean the vehicle with a soft, dry cloth. To restore shine to plastic parts, use a non-wax furniture polish. Do not use car wax. Do not use abrasive cleaners.
- Do not drive the vehicle in loose dirt, sand or fine gravel which could damage the moving parts, motors or the electric system.
- When not using, all the electrical source should be turned off. Turn off the power switch and disconnect the battery connection.

LAND ROVER RANGE ROVER VELAR

BATTERY POWERED ELECTRIC RIDE-ON

Dist. by TDC USA, Inc. Fairfield, NJ 07004
©2022 All Rights Reserved. Made in China.
Item #61129

Questions and Comments
1-800-599-8898 (9 am - 5 pm EST)
www.tdcusainc.com

This products meets ASTM F963 and CPSIA requirements for electric vehicles.