

# Classic Park Bench



## Assembly Instructions

**Made in China**

The owner's manual contains important safety information as well as assembly, use and maintenance instructions. Keep the packaging and bags away from children and dispose of all packaging properly before use. Keep this manual for future reference.



**PLEASE DO NOT  
RETURN THIS  
PRODUCT  
TO THE STORE**

**We will be happy to correct any problems that you may have, or answer any of your questions regarding the purchase of this product. Please contact us at our Toll Free customer service number 1-800-599-8898 for any assistance and replacement parts. Thank You.**







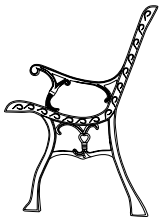
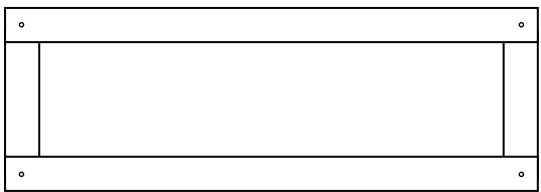
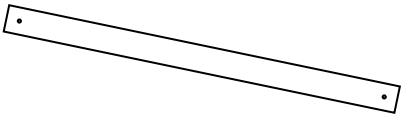
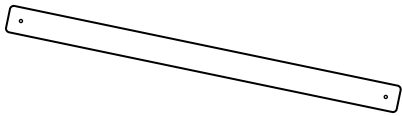

Dist. by TDC USA, Inc. Fairfield, NJ 07004  
©2021 All Rights Reserved.  
Made in China  
Item 21134  
[www.tdcusainc.com](http://www.tdcusainc.com)

 **WARNING!**

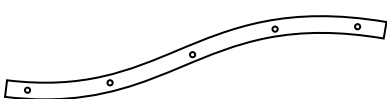
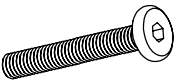
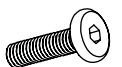
- **Keep all children and pets away from assembly area. Children and pets should be supervised when they are in the area of the product construction.**
- **Some parts may contain sharp edges. When assembling and using this product, basic safety precautions should always be.**
- **Please read all the instructions and warnings before assembling. In order to make the whole product adjust to the best, please install all the screws on the product and tighten all the screws after adjusting the product which can stand on the floor even. Not intended for commercial use.**
- **Check all bolts for tightness before use.**
- **IMPORTANT - check and tighten bolts often to keep them secure**

• **CHOKING HAZARD** - Small parts. Not suitable for children under 36 months. The product contains small parts, keep children away when assembling.

• **ADULT ASSEMBLY REQUIRED.**  
Always remove protective material and poly bags and dispose before assembly.

	<b>A (x1)</b> Armrest		<b>B (x1)</b> Armrest
		<b>C (x1)</b> Back	
	<b>D (x4)</b> Slat		<b>E (x1)</b> Rounded Slat
	<b>F (x2)</b> Seat Support		<b>G (x1)</b> Slat Support
	<b>H (x14)</b> M6x30 Bolt		<b>I (x2)</b> M6x20 Bolt
	<b>J (x14)</b> M11 Washer		<b>K (x2)</b> M15 Washer
	<b>L (x16)</b> Nut		<b>M (x7)</b> Screw
	<b>N (x4)</b> Cap		

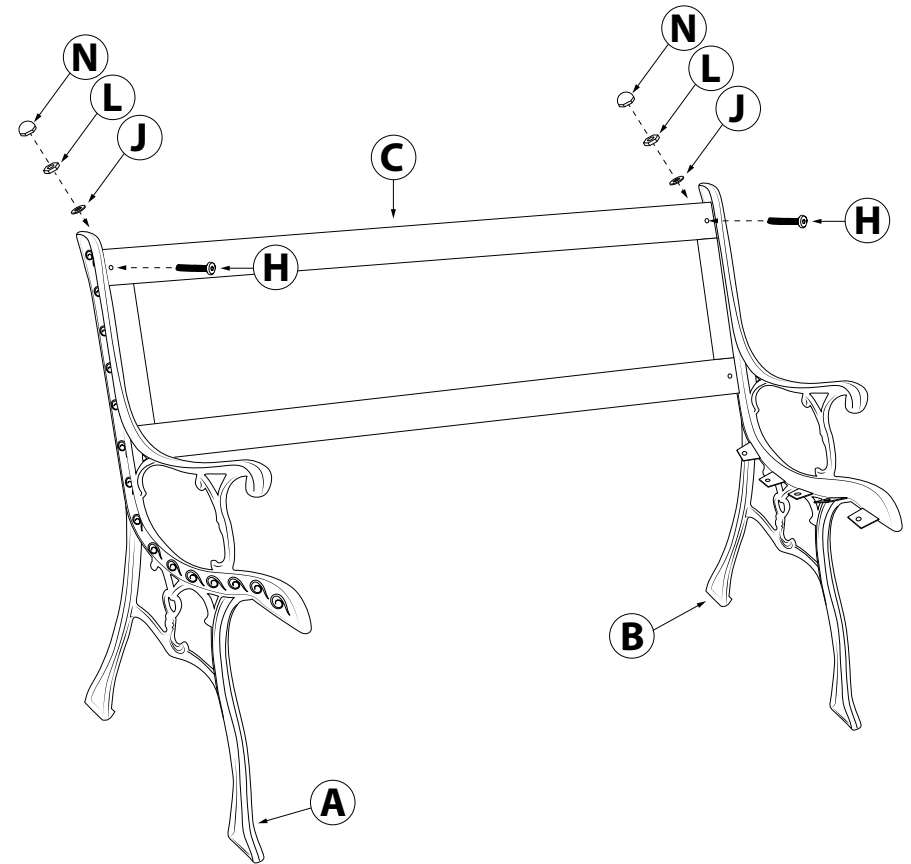

**Step 1:**

Insert one M6x30 Bolt (H) through eyelet at the top-left of Back (C), through back support bracket at the top of Armrest (A), place one M11 Washer (J) over bolt, and use one Nut (L) to hold parts in place. **Do not tighten bolts until assembly is complete.** Follow these steps to assemble the top-right of Back (C) to Armrest (B).

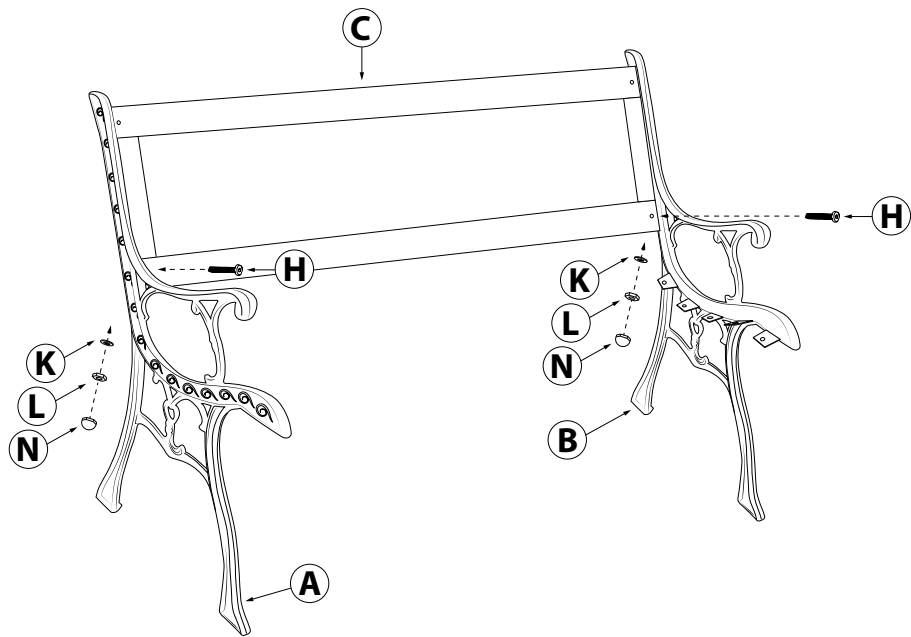

### Step 2:

Insert one M6x30 Bolt (H) through eyelet at the bottom-left of Back (C), through back support bracket below the bracket at the top of Armrest (A), place one M15 Washer (K) over bolt, and use one Nut (L) to hold parts in place. Follow these steps to assemble the bottom-right of Back (C) to Armrest (B).

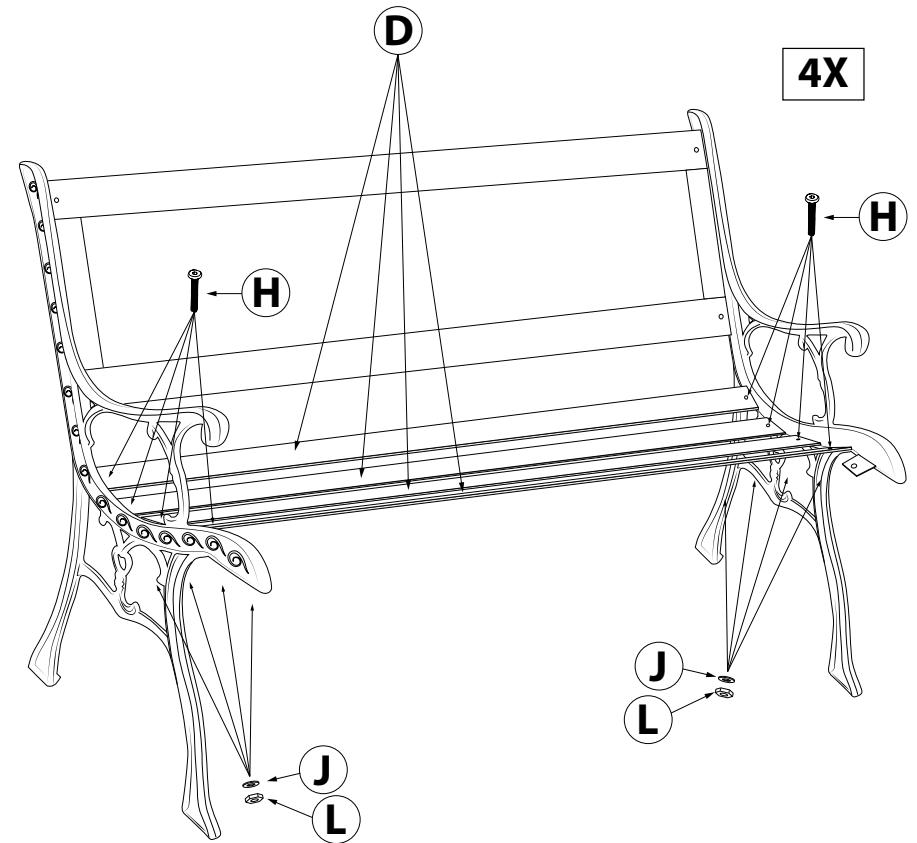

### Step 3:

Place Slat (D) over back slat support brackets on both Armrests (A & B).

Insert one M6x30 Bolt (H) through eyelet at the end of Slat (D), through the slat support bracket of Armrest (A), place one M11 Washer (J) over bolt, and use one Nut (L) to hold parts in place. Follow this step to assemble the opposite end of Slat (D) to slat support bracket of Armrest (B). Follow these steps to assemble the three remaining Slats (D) with the next three slat support brackets of Armrests (A & B).

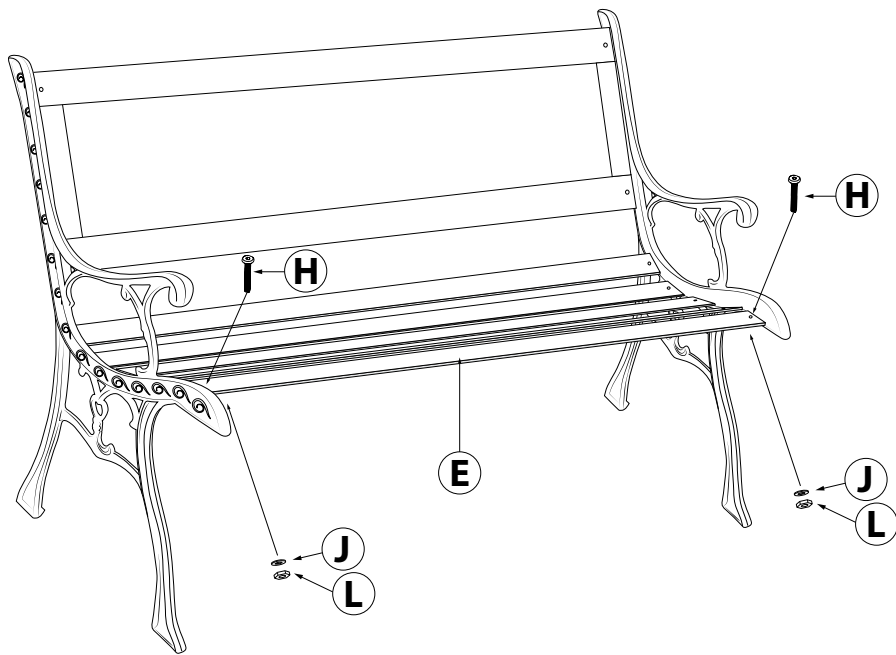

### Step 4:

Insert one M6x30 Bolt (H) through eyelet at the end of Rounded-slat (E), through the front slat support bracket of Armrest (A), place one M11 Washer (J) over bolt, and use one Nut (L) to hold parts in place. Follow this step to assemble the opposite end of Rounded-slat (E) to front slat support bracket of Armrest (B).

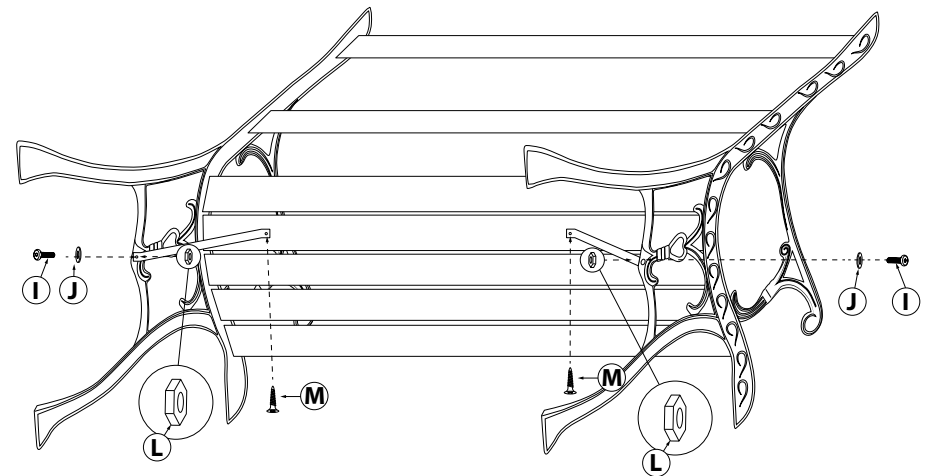

### Step 5:

Insert one M6x20 Bolt (I) with M11 Washer (J) through the eyelet of the bottom horizontal bar of Armrest (A), through the longer, flattened end of Seat Support (F), and use one Nut (L) to hold parts together. Use a screwdriver or power drill with screwdriver fitting to drill one Screw (M) through the opposite end of Seat Support (F) and into the second Slat (D) [the slat that put in place after the initial one near the back of seat]. Follow these steps to assemble the second Seat Support (F) to Armrest (B).

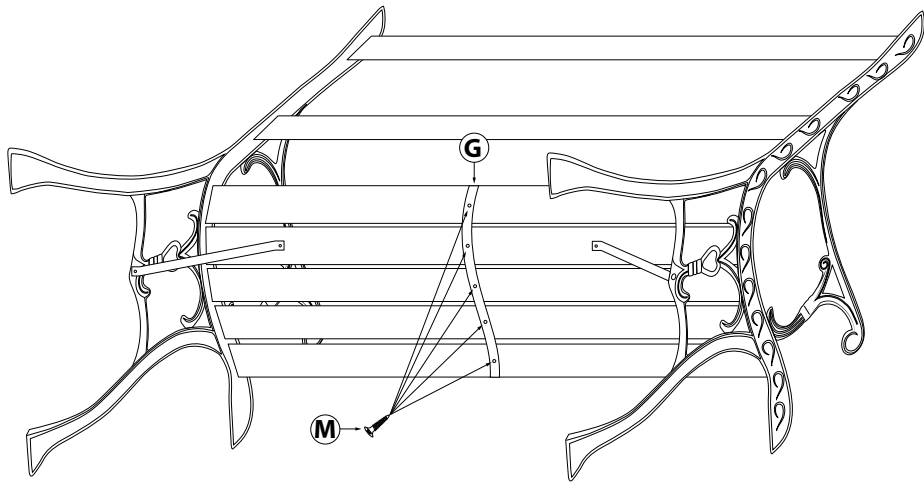

### Step 6:

Use a screwdriver or power drill with screwdriver fitting to drill one Screw (M) through each eyelet of Slat Support (G) and into the center of each Slat (D) and into the Round-slat (E). Tighten all bolts left loose throughout assemble process. Place the Caps (N) over the four Nuts (L) used to assemble the Back (C) to both Armrests (A & B). Your Park Bench is now ready to be used.

# Classic Park Bench

Dist. by TDC USA, Inc. Fairfield, NJ 07004  
©2021 All Rights Reserved. Made in China.

Item #21134

**Questions and Comments**  
**1-800-599-8898 (9 am - 5 pm EST)**  
**[www.tdcusainc.com](http://www.tdcusainc.com)**