

Kid's Picnic Table & Stool Set

Dist. by TDC USA, Inc. Fairfield, NJ 07004
©2021 All Rights Reserved. Made in China.
Item #22578

Questions and Comments
1-800-599-8898 (9 am - 5 pm EST)
www.tdcusainc.com

Kid's Picnic Table & Stool Set



Assembly Instructions

Made in China

The owner's manual contains important safety information as well as assembly, use and maintenance instructions. Keep the packaging and bags away from children and dispose of all packaging properly before use. Keep this manual for future reference.



**PLEASE DO NOT
RETURN THIS
PRODUCT
TO THE STORE**

We will be happy to correct any problems that you may have, or answer any of your questions regarding the purchase of this product. Please contact us at our Toll Free customer service number 1-800-599-8898 for any assistance and replacement parts. Thank You.

Dist. by TDC USA, Inc. Fairfield, NJ 07004
©2021 All Rights Reserved.
Made in China
Item 22578
www.tdcusainc.com

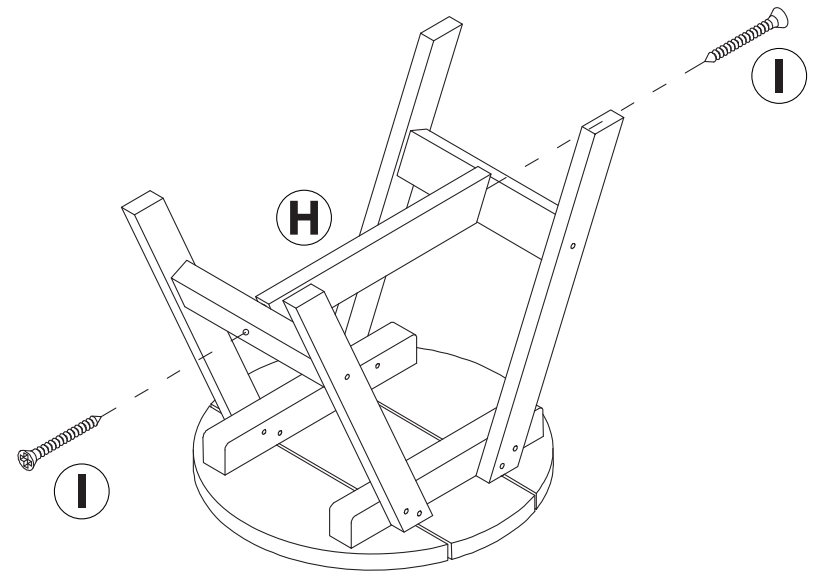

Step 3:

Set Seat Support (H) in between both Seat Braces (G) underneath seat. Insert one 3.5x35mm Screw (I) through the center of both Seat Braces (G) and into each end of Seat Support (H). Tighten all screws left loose throughout assembly process and the seat is ready to be used.

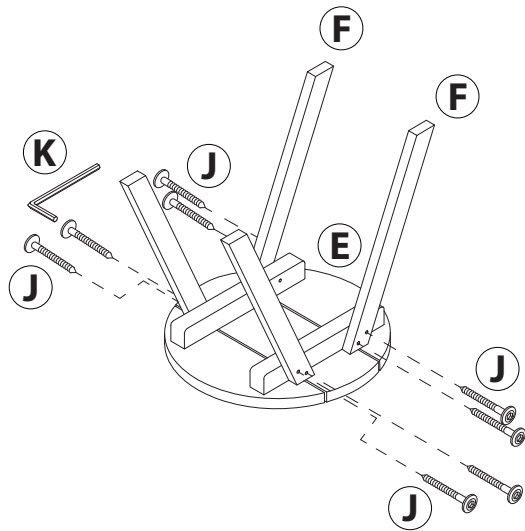

Step 1:

Set the Seat (E) on a soft, non-abrasive surface. Insert two 6x40mm Screws (J) through the tops of each Seat Leg (F) using Hex Key (K). **Do not tighten screws down until assembly of the seat is complete.**

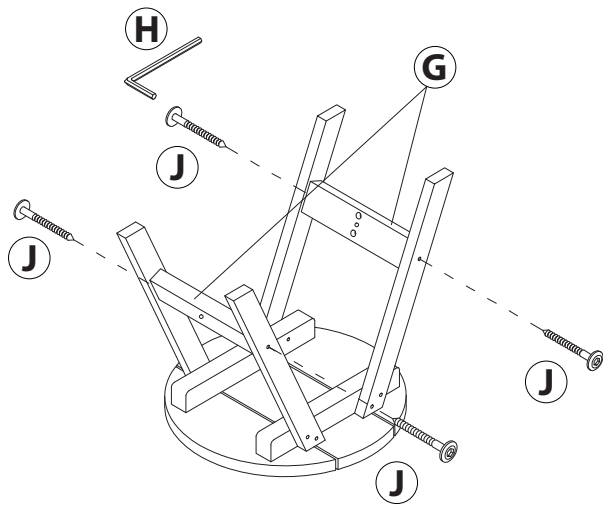

Step 2:

Place Seat Brace (G) in between two Seat Legs (F). Insert one 6x40mm Screw (J) through the side of both Seat Legs (F) and into the ends of Seat Brace (G). Follow these steps to assemble the second Seat Brace (G) to the other set of Seat Legs (F).

⚠ WARNING!

- Keep all children and pets away from assembly area. Children and pets should be supervised when they are in the area of the product construction.
- Some parts may contain sharp edges. When assembling and using this product, basic safety precautions should always be.
- Please read all the instructions and warnings before assembling. In order to make the whole product adjust to the best, please install all the screws on the product and tighten all the screws after adjusting the product which can stand on the floor even. Not intended for commercial use.
- Check all bolts for tightness before use.
- **IMPORTANT** - check and tighten bolts often to keep them secure

• **CHOKING HAZARD** - Small parts. Not suitable for children under 36 months. The product contains small parts, keep children away when assembling.

• **ADULT ASSEMBLY REQUIRED.**
Always remove protective material and poly bags and dispose before assembly.

TABLE PARTS

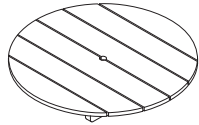

A (x1)
Table

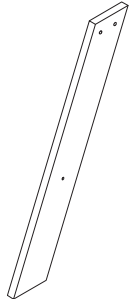

B (x4)
Table Leg

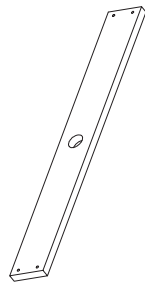

C (x1)
Table Support

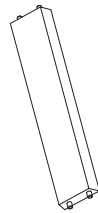

D (x2)
Table Brace

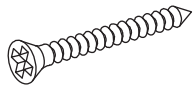

I (x4)
3.5x35mm Screw

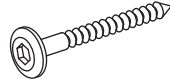

J (x12)
6x40mm Screw

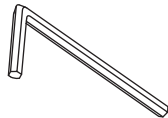

K (x1)
Hex Key

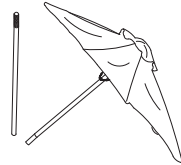

L (x1)
Umbrella

STOOL PARTS

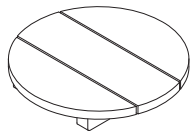

E (x1)
Seat

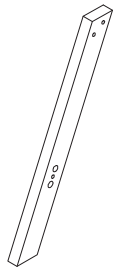

F (x8)
Seat Legs

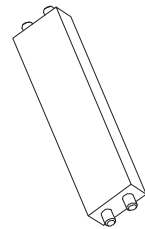

G (x4)
Seat Brace

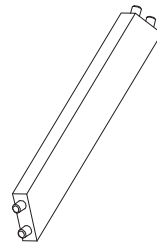

H (x2)
Seat Support

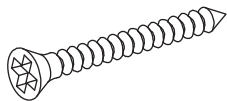

I (x4)
3.5x35mm Screw

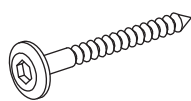

J (x24)
6x40mm Screw



K (x1)
Hex Key



Step 5:

Insert the lower pole of Umbrella (L) through the center of Table (A) and through the eyelet of Table Support (C).

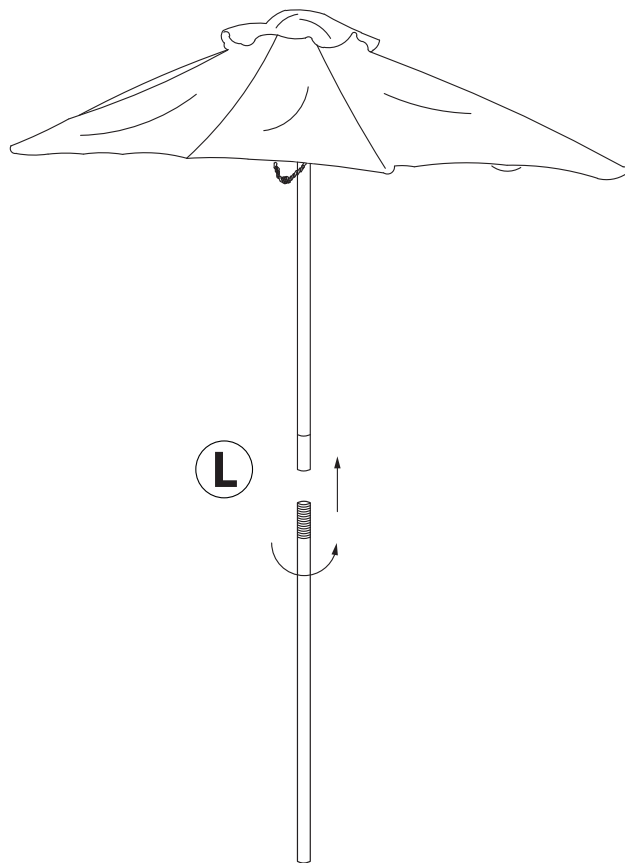

Step 4:

Screw in the lower pole of Umbrella (L) to the umbrella frame [with canopy ribs and canopy] by turning it clockwise till it is locked in place.

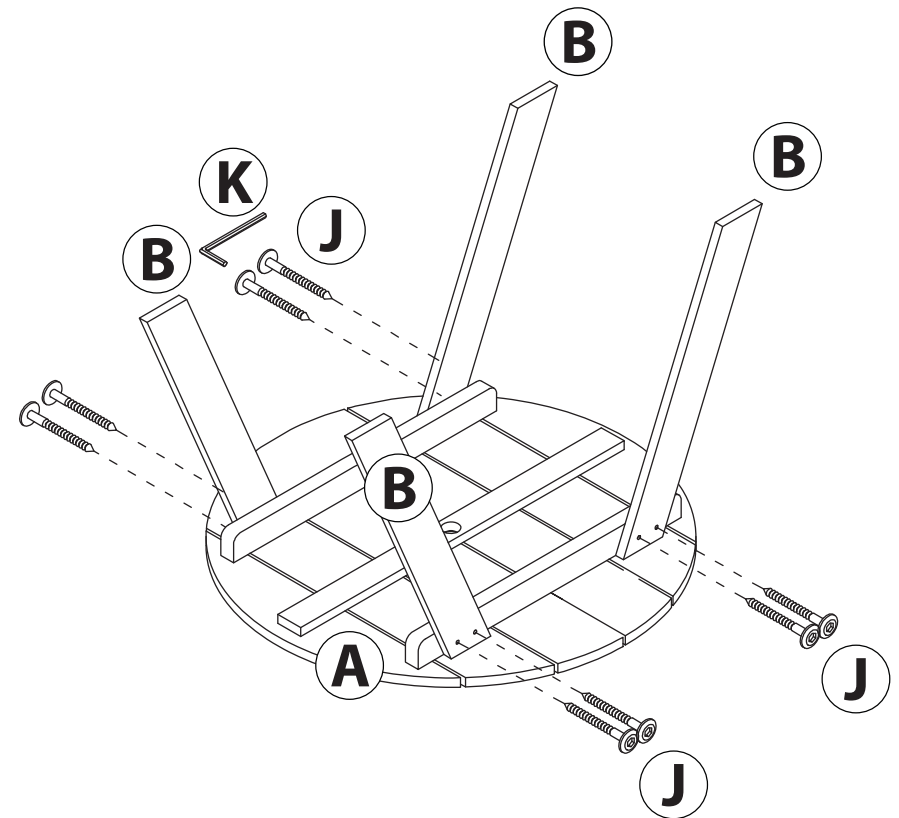

Step 1:

Set the Table (A) on a soft, non-abrasive surface. Insert two 6x40mm Screws (J) through the tops of each Table Leg (B) using Hex Key (K). **Do not tighten screws down until assembly of the table is complete.**

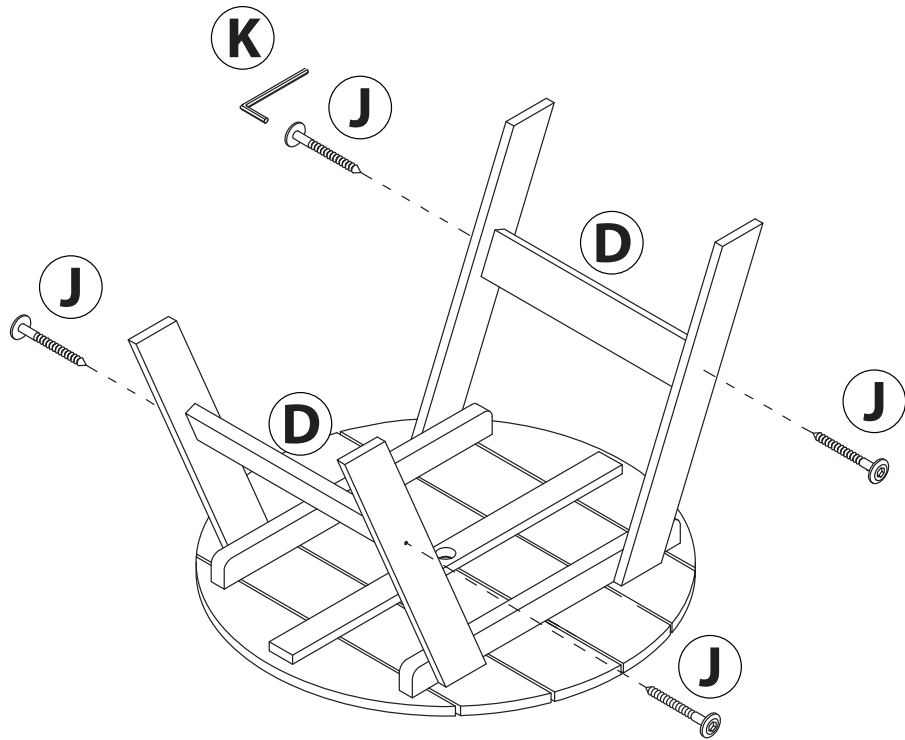

Step 2:

Place Table Brace (D) in between two Table Legs (B). Insert one 6x40mm Screw (J) through the side of both Table Legs (B) and into the ends of Table Brace (D). Follow these steps to assemble the second Table Brace (D) to the other set of Table Legs (B).

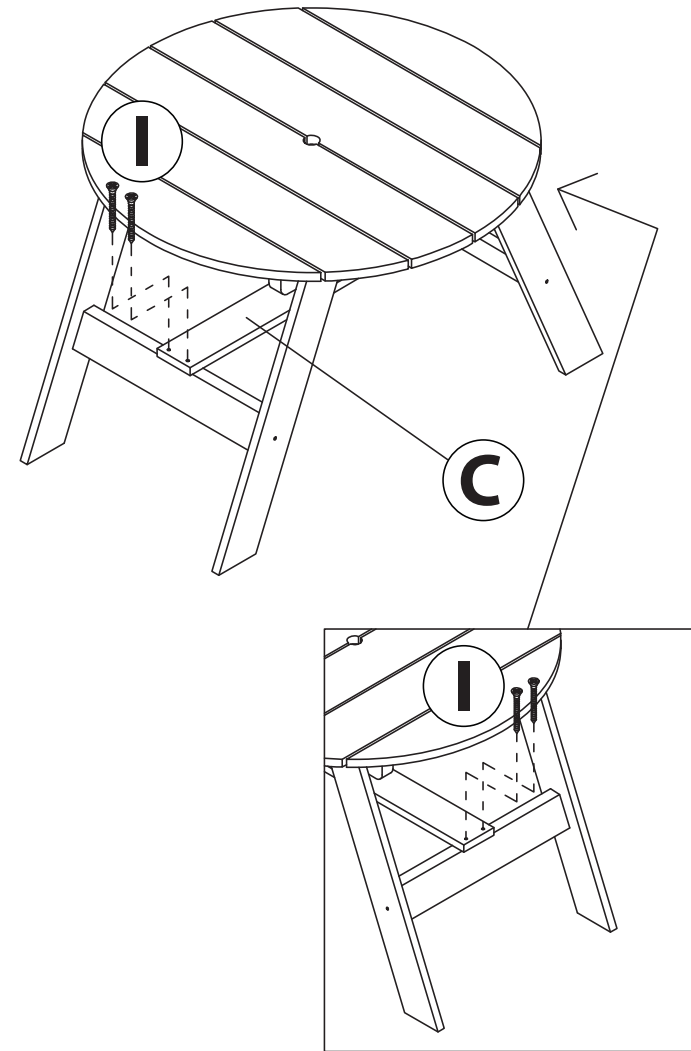

Step 3:

Set Table Support (C) on top of both Table Braces (D) underneath table. Insert two 3.5x35mm Screws (I) through one end of Table Support (C) and into the top of Table Brace (D) using a screwdriver (not included). Follow this step to connect the opposite side of Table Support (C) to the second Table Brace (D). Tighten all screws left loose throughout assembly process and the table is ready to be used.