

7 Piece Wicker Bar Set



Assembly Instructions

Made in China

The owner's manual contains important safety information as well as assembly, use and maintenance instructions. Keep the packaging and bags away from children and dispose of all packaging properly before use. Keep this manual for future reference.



**PLEASE DO NOT
RETURN THIS
PRODUCT
TO THE STORE**

We will be happy to correct any problems that you may have, or answer any of your questions regarding the purchase of this product. Please contact us at our Toll Free customer service number 1-800-599-8898 for any assistance and replacement parts. Thank You.

Dist. by TDC USA, Inc. Fairfield, NJ 07004
©2020 All Rights Reserved.
Made in China
Item 22475
www.tdcusainc.com





⚠ WARNING!

- Keep all children and pets away from assembly area. Children and pets should be supervised when they are in the area of the product construction.
- Some parts may contain sharp edges. When assembling and using this product, basic safety precautions should always be.
- Please read all the instructions and warnings before assembling. In order to make the whole product adjust to the best, please install all the screws on the product and tighten all the screws after adjusting the product which can stand on the floor even. Not intended for commercial use.
- Check all bolts for tightness before use.
- **IMPORTANT** - check and tighten bolts often to keep them secure



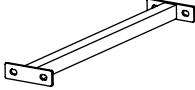
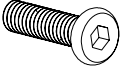
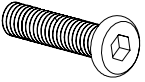

• **CHOKING HAZARD** - Small parts. Not suitable for children under 36 months. The product contains small parts, keep children away when assembling.

• **ADULT ASSEMBLY REQUIRED.**
Always remove protective material and poly bags and dispose before assembly.

Stool Parts (x6)

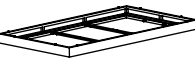
 A (x1) Stool Seat	 B (x2) Stool Leg	 C (x2) Stool Support	 D (x8) M6x15 Bolt
 E (x4) M6x30 Bolt	 F (x12) Washer	 G (x1) Hex Key	

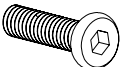
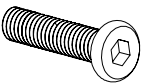
Bar Table Parts (x1)

 H (x1) Bar Table	 J (x2) Bar Leg	 K (x2) Bar Support	 D (x8) M6x15 Bolt
 E (x4) M6x30 Bolt	 F (x12) Washer		

* 6 Stools are included in this set

Step 1:

Place Stool Seat (A) upside down on the ground. Place Stool Leg (B) on the side of Stool Seat (A) where there are screw-threading intended for bolts to be inserted into. Insert two Bolts M6x30 (E) with Washers (F) through holes of Stool Leg (B) and into the screw threading of Stool Seat (A). Follow this step to assemble the second Stool Leg (B) on the opposite side of Stool Seat (A); do not tighten bolts all the way until assembly is completed.

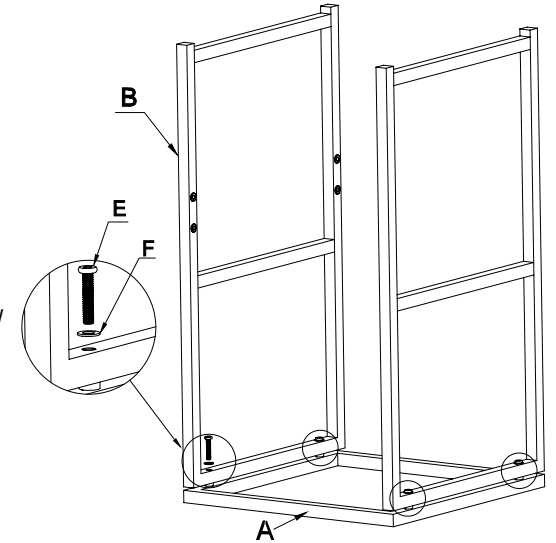

Step 2:

Place Stool Support (C) in between both Stool Legs (B). Insert two Bolts M6x15 (D) with Washers (F) through holes at either end of Stool Support (C) and into the screw-threading found near the center of Stool Legs (B). Follow these steps to assemble the second Stool Support (C) on the opposite side of Stool Legs (B). Tighten all bolts left loose throughout assembly process. Follow these steps to assemble the remaining stools for this set.

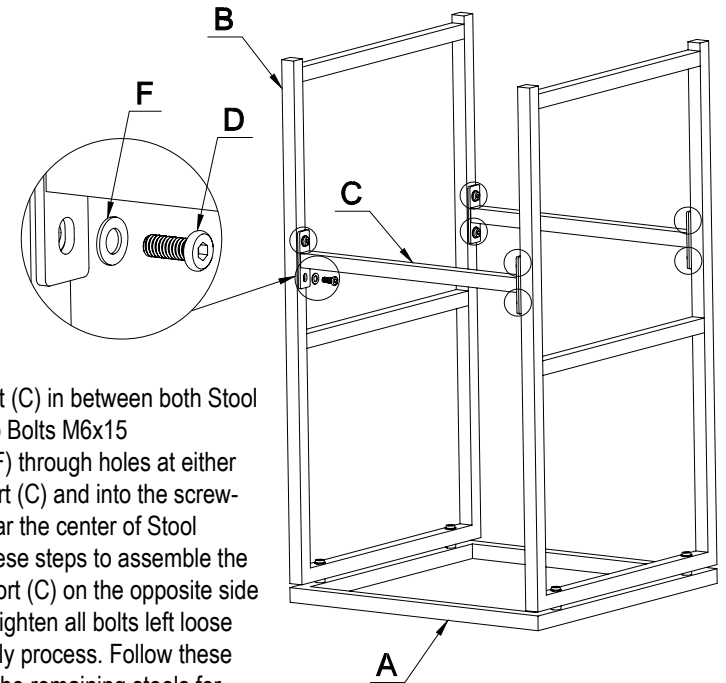

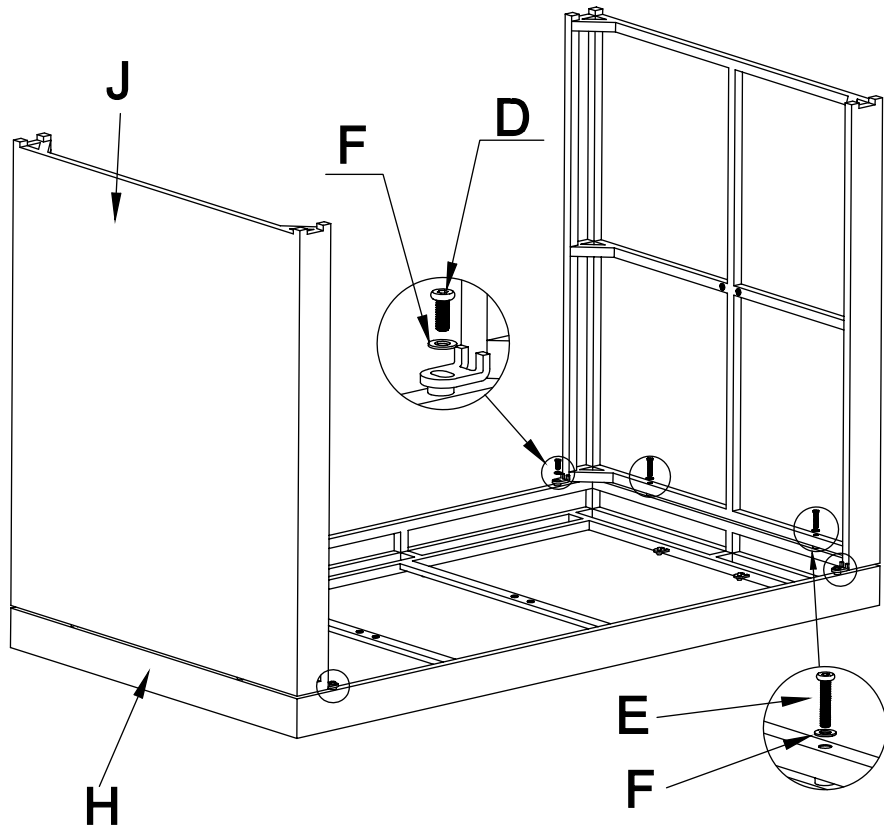

Step 1:

Cut the straps that secure the glass to the bar rim. Carefully remove the glass by having one person on either end. Carefully set it aside once removed. Carefully place Bar Table (H) upside down on the ground. Place Bar Leg (J) on the side of Bar Table (H) where there are screw-threading intended for bolts to be inserted into. Insert two Bolts M6x30 (E) with Washers (F) through holes found at the center of Bar Leg (J) and into the screw-threading found at end of rim of Bar Table (H); do not tighten bolts all the way until assembly is completed. Insert two Bolts M6x15 (D) with Washers (F) through holes found on either side of Bar Leg (J) and into the screw-threading found on the sides of rim of Bar Table (H). Follow these steps to assemble the second Bar Leg (J) on the opposite side of Bar Table (H).

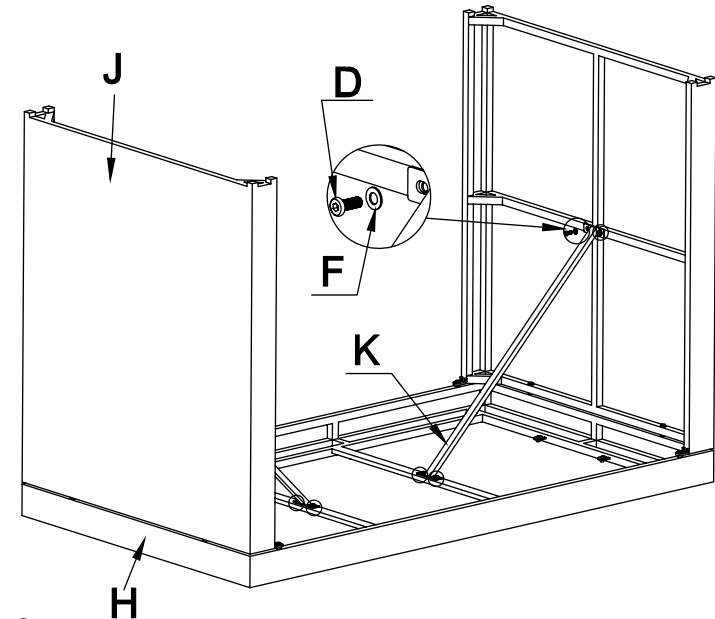

Step 2:

Place Bar Support (K) against the center of Bar Leg (J) and the bar supporting the glass of Bar Table (H) as illustrated here. Insert two Bolts M6x15 (D) with Washers (F) through holes at the end of Bar Support (K) and into the screw-threading found at the center of Bar Leg (J). Insert two Bolts M6x15 (D) with Washers (F) through holes at opposite end of Bar Support (K) and into the screw-threading found on bar that supports glass of Bar Table (H). Follow these steps to assemble the second Bar Support (K) to the other Bar Leg (J) and to the Bar Table (H). Tighten all bolts left loose throughout assembly process.

Step 3:

Carefully turn the bar right-side up when finished. Using two people, carefully place the glass back in place inside of the bar rim.

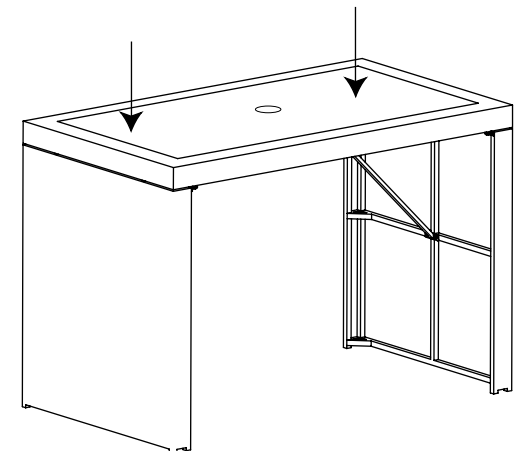

7 Piece Wicker Bar Set

Dist. by TDC USA, Inc. Fairfield, NJ 07004
©2020 All Rights Reserved. Made in China.
Item #22475

Questions and Comments
1-800-599-8898 (9 am - 5 pm EST)
www.tdcusainc.com